



## *Service Manual*

**Lexmark™ C720  
Color Laser Printer**

**Machine Type 5024-001**

- ***Table of Contents***
- ***Start Diagnostics***
- ***Safety and Notices***
- ***Trademarks***
- ***Index***
- ***Manuals Menu***

**LEXMARK™**

*Lexmark and Lexmark with diamond design are trademarks of Lexmark International, Inc., registered in the United States and/or other countries.*

**5024-001**

**Edition: December 2002**

**The following paragraph does not apply to any country where such provisions are inconsistent with local law:** LEXMARK INTERNATIONAL, INC. PROVIDES THIS PUBLICATION "AS IS" WITHOUT WARRANTY OF ANY KIND, EITHER EXPRESS OR IMPLIED, INCLUDING, BUT NOT LIMITED TO, THE IMPLIED WARRANTIES OF MERCHANTABILITY OR FITNESS FOR A PARTICULAR PURPOSE. Some states do not allow disclaimer of express or implied warranties in certain transactions; therefore, this statement may not apply to you.

This publication could include technical inaccuracies or typographical errors. Changes are periodically made to the information herein; these changes will be incorporated in later editions. Improvements or changes in the products or the programs described may be made at any time.

Comments may be addressed to Lexmark International, Inc., Department D22A/032-2, 740 West New Circle Road, Lexington, Kentucky 40550, U.S.A or e-mail at [ServiceInfoAndTraining@Lexmark.com](mailto:ServiceInfoAndTraining@Lexmark.com). Lexmark may use or distribute any of the information you supply in any way it believes appropriate without incurring any obligation to you. You can purchase additional copies of publications related to this product by calling 1-800-553-9727. In other countries, contact your point of purchase.

Lexmark, Lexmark with diamond design, MarkNet, and MarkVision are trademarks of Lexmark International, Inc., registered in the United States and/or other countries.

PCL is a registered trademark of the Hewlett-Packard Company.

PostScript is a registered trademark of Adobe Systems Incorporated.

Other trademarks are the property of their respective owners.

**© Copyright Lexmark International, Inc. 2001, 2002.**

**All rights reserved.**

#### **UNITED STATES GOVERNMENT RESTRICTED RIGHTS**

This software and documentation are provided with RESTRICTED RIGHTS. Use, duplication or disclosure by the Government is subject to restrictions as set forth in subparagraph (c)(1)(ii) of the Rights in Technical Data and Computer Software clause at DFARS 252.227-7013 and in applicable FAR provisions: Lexmark International, Inc., Lexington, KY 40550.

**U.S.A. P/N: 12G3667**

---

## Table of Contents

<b>Notices and Safety Information</b> .....	<b>xiii</b>
Laser Notices .....	xiii
Safety Information .....	xxiv
<b>Preface</b> .....	<b>xxx</b>
<b>General Information</b> .....	<b>1-1</b>
Maintenance Approach .....	1-1
Tools Required for Service .....	1-1
Serial Number .....	1-2
Acronyms .....	1-3
Standard Features .....	1-4
Printer (Main) .....	1-4
Printer Options .....	1-11
Printer Identification .....	1-12
Options Identification .....	1-13
Printer Theory of Operation .....	1-14
Printer Systems Description .....	1-15
Basic Principles of Color Printing .....	1-15
Mechanical and Electrical Structures .....	1-15
Printer Component Systems .....	1-17
Basic Process of Color Printing .....	1-18
Print System and Transfer System .....	1-19
Structure of OPC Belt (Photo Developer Cartridge) .....	1-20
Basic Structure of the Print System .....	1-21
Details of the Print System .....	1-23
Charging Process .....	1-23
Exposing Process .....	1-25
Developing Process .....	1-26
First Transfer (Drum) Process .....	1-28
Belt Discharge (Erase Lamp) Process .....	1-30
Belt Cleaning Process .....	1-31
Details of the Transfer System .....	1-32
Second Transfer (Paper) Process .....	1-32
Paper Discharging Process .....	1-33
Drum Cleaner Process .....	1-34
Details of the Optical System .....	1-35
Details of the Paper Transportation System .....	1-37
Fusing Unit .....	1-39
Fusing Process .....	1-41
Control System Structure .....	1-42

Electrical System and Function .....	1-42
Control of Print Process .....	1-43
Print Sequence Diagram .....	1-44
Laser Drive Control Circuit .....	1-45
Interface Control .....	1-47
Lower Feed Unit Theory of Operation .....	1-48
Duplex Theory of Operation .....	1-49
<b>Diagnostic Information .....</b>	<b>2-1</b>
Start .....	2-1
Service Error Codes .....	2-2
Operator Messages .....	2-9
Paper Jam Messages .....	2-27
Symptom Tables .....	2-32
Printer Symptom Table .....	2-32
Print Quality Symptom Table .....	2-34
Optional Lower Feed Unit Symptom Table .....	2-36
Optional Duplex Unit Symptom Table .....	2-37
Printer Service Checks .....	2-38
901—Yellow Developer Clutch Service Check .....	2-38
902—Magenta Developer Clutch Service Check .....	2-39
903—Cyan Developer Clutch Service Check .....	2-40
904—Black Developer Clutch Service Check .....	2-41
905—Yellow/Black Developer Solenoid Service Check .....	2-42
906—Magenta/Cyan Developer Solenoid Service Check .....	2-43
907—Toner Empty Sensor P.W.B. Board Service Check .....	2-44
910—Developer Motor (DM) Drive Service Check .....	2-45
911—Main Motor (MM) Service Check .....	2-47
915—Control Cooling Fan Service Check .....	2-50
916—Ozone Fan Service Check .....	2-51
917—Fuser Heater Fan Service Check .....	2-52
918—Erase Lamp Service Check .....	2-53
920, 922, 923—Fuser Unit Service Check .....	2-54
921—Fuser Thermistor Service Check .....	2-55
981—Duplex Motor (DPM1, DPM2) Service Check .....	2-56
982—Duplex Upper Solenoid (DSOL-U) Service Check .....	2-58
983— Duplex Fan (D-FAN) Service Check .....	2-59
984—Duplex Lower Solenoid (DSOL-L) Service Check .....	2-60
990—Transfer Drum Encoder Sensor (HPSEN) Service Check .....	2-61
991—Transfer Roller Cam Clutch (TRCM) Service Check .....	2-63
992—Drum Cleaner Brush Cam Clutch (FBCM) Service Check .....	2-64
993—Cleaner Clutch (FBCL) Service Check .....	2-65



994—Fuser Clutch (FUCL) Service Check ..... 2-66

995—OPC Belt Cartridge, Belt Marker Sensor (PBS)  
Service Check ..... 2-67

997—High Voltage Power Supply Unit (HVU) Service Check . 2-69

OPC Belt (Photo Developer) Cartridge Drive Service Check .. 2-70

Operator Panel Service Check. .... 2-70

Options No Power Service Check ..... 2-72

Paper Discharge Service Check ..... 2-73

Printer No Power Service Check ..... 2-74

Toner Feed Service Check ..... 2-75

Waste Toner Feed Service Check ..... 2-76

Paper Feed Service Checks ..... 2-77

Printer Paper Feed Service Check ..... 2-77

Lower Feed Unit Paper Feed Service Check ..... 2-79

Duplex Paper Feed Service Check ..... 2-81

Print Quality Service Checks ..... 2-83

Background Service Check ..... 2-83

Back Stain Service Check ..... 2-84

Banding Service Check ..... 2-85

Black Line Service Check ..... 2-86

Color Misregistration Service Check ..... 2-87

Insufficient Fusing Service Check ..... 2-88

Insufficient Gloss Service Check ..... 2-89

Jitter Service Check ..... 2-90

Missing Image at Edge Service Check ..... 2-91

Mixed Color Image Service Check ..... 2-92

Mottle Service Check ..... 2-93

Residual Image Service Check ..... 2-94

Ribbing Service Check ..... 2-95

Toner Drop Service Check ..... 2-96

Vertical Line Service Check ..... 2-97

Vertical Staggering Image Service Check ..... 2-98

Vertical White Band Service Check ..... 2-99

White Band Service Check ..... 2-100

White Line I Service Check ..... 2-101

White Line II Service Check ..... 2-102

White Spot / Black Spot Service Check ..... 2-103

White Print Service Check ..... 2-104

Wrinkle / Image Migration Service Check ..... 2-105

Spacing Table ..... 2-106

Roller Specifications ..... 2-106

**Diagnostic Aids ..... 3-1**

Disabling Download Emulations .....	3-1
Paper Jam Sequence .....	3-2
Diagnostic Mode .....	3-5
Diagnostics Menu Structure .....	3-6
Print Quality Test Pages .....	3-6
Print Registration .....	3-7
Setting Tray 2 Left Margin .....	3-7
Setting Top Margin .....	3-7
Print Tests .....	3-8
Hardware Tests .....	3-9
LCD Test .....	3-9
Button Test .....	3-9
Parallel Wrap Test .....	3-10
ROM Memory Test .....	3-10
DRAM Memory Test .....	3-11
Serial Wrap Test .....	3-12
Duplex Tests .....	3-13
Duplex Left Margin .....	3-13
Device Tests .....	3-14
Quick Disk Test .....	3-14
Disk Test/Clean .....	3-14
Flash Test .....	3-15
Printer Setup .....	3-16
Setting the Page Count .....	3-16
Viewing the Permanent Page Count .....	3-16
Serial Number .....	3-16
Setting Configuration ID .....	3-17
Parallel Strobe Adjustment .....	3-18
Resetting Counters .....	3-19
Error Log .....	3-19
Viewing the Error Log .....	3-19
Clearing the Error Log .....	3-20
Restore EP Factory Defaults .....	3-20
Exiting Diagnostic Mode .....	3-21
Print Quality Test Page .....	3-22
<b>Repair Information .....</b>	<b>4-1</b>
Removal and Cleaning Precautions .....	4-1
Handling the Printed Circuit Boards with	
MOS ICs .....	4-2
During Transportation/Storage: .....	4-2
During Replacement: .....	4-2
During Inspection: .....	4-2

Image Belt Cartridge/OPC .....	4-3
During Transportation/Storage.....	4-3
Handling.....	4-3
Parts Not To Be Touched.....	4-3
Adjustments .....	4-4
Printer Removal Procedures .....	4-5
Precautions to Take Before Maintenance Work.....	4-5
Printer Covers .....	4-6
Upper Side Cover (L) Removal .....	4-7
Side Cover (R) Removal .....	4-8
Side Cover (L) Removal.....	4-10
Side F Cover (L) Removal .....	4-11
Top Cover Assembly Removal.....	4-12
Paper Exit Cover / Paper Exit Front Cover / Paper Exit Cover (U) Removal.....	4-13
Transfer Cover Removal .....	4-15
Rear Cover Removal .....	4-16
Rear Cover (U) Removal .....	4-17
Base Cover (R) Removal .....	4-18
Base Cover (L) Removal .....	4-20
Cleaner Cover Removal.....	4-21
Front Cover Removal.....	4-22
Printer Board Removals .....	4-23
Printer Board Layout .....	4-23
Main Engine (MCTL P.W.B.) Board Removal .....	4-24
IOD1 P.W.B. Removal .....	4-26
IOD2 P.W.B. Removal .....	4-28
Panel P.W.B. (Operator Control) Removal .....	4-29
Power Supply Unit (Low Voltage Power Supply - LVPS) Removal .....	4-30
High Voltage Power Supply Unit (HVU) Removal .....	4-33
Erase Lamp Removal.....	4-35
Motor Removals .....	4-37
Fan / Motor Layout .....	4-37
Main Motor (MM) / BD Gear Assembly Removal.....	4-38
Main Gear Unit Removal .....	4-40
Developer Motor (DM) Removal .....	4-41
Developer Drive Unit Removal.....	4-42
Optical Unit (Printhead Scanner Motor Assembly) Removal ...	4-44
Control Fan (3) (CTFAN) Removal .....	4-47
Heater Fan (HTFAN) Removal.....	4-49
Ozone Fan (OZFAN) / Ozone Duct Assembly Removal .....	4-50
Clutch and Solenoid Removals .....	4-52

Clutch (FUCL, FBCL, RECL) Removal .....	4-53
Paper Feeder Clutch (PCLU) Removal .....	4-54
Developer Clutch (DCLK, DCLY, DCLM, DCLC) Removal .....	4-55
Cam Clutch (FBCM, TRCM) Removal .....	4-57
Sensor Removals .....	4-58
Interlock Switch (Front) Removal .....	4-59
Interlock Switch (Top) Removal .....	4-60
Interlock Switch (Rear) Removal .....	4-61
Paper Sensor (Paper Feeding Sensor PT1) Removal .....	4-63
Paper Exit Sensor (PT2) Removal .....	4-64
Paper Empty Sensor (PEU) / OHP Sensor (OHP) Removal .....	4-65
Paper Size Sensor (PSU) Removal .....	4-67
Drum Jam Sensor (DPJ) Removal .....	4-68
Oil Sensor (OIL) Removal .....	4-69
Drum Encoder Sensor (HPSEN) Removal .....	4-70
Belt Sensor (PBS) Removal .....	4-72
Waste Toner Sensor (TBLE/TBFL) (Waste Toner Holder Assembly) Removal .....	4-73
Toner Sensor Assembly (TPD) / (TTR) Removal .....	4-74
Cleaning Roller Sensor (FCS) Removal .....	4-76
Paper Full Sensor (PFUL) Removal .....	4-77
Toner Key Sensor (TNK) Removal .....	4-78
Transfer Unit (Rollers and Drum) Removal .....	4-79
Transfer Unit Removal .....	4-79
Registration Roller Removal .....	4-80
Transfer Drum Removal .....	4-81
Paper Feed Roller / Separator Pad Removal .....	4-83
Front Cover Unit Removal .....	4-84
Paper Exit Unit / Paper Exit Roller Removal .....	4-86
Discharger Brush Removal .....	4-88
Waste Toner Feeder (U) (Stay 'A' Assembly) Removal .....	4-89
Fuser Connector Removal .....	4-90
Waste Toner Feeder (L) Removal .....	4-91
Fuser Unit Removal .....	4-93
Lower Feeder Unit (LFU) Removals .....	4-94
Lower Feeder Unit Top Cover (R) Removal .....	4-95
Lower Feeder Unit Top Cover (L) Removal .....	4-96
Lower Feeder Unit Front Top Cover Removal .....	4-97
Lower Feeder Unit Base Cover (R) Removal .....	4-98
Lower Feeder Unit Base Cover (L) Removal .....	4-99
Lower Feeder Unit Paper Sensor Removal .....	4-100
Lower Feeder Unit Paper Size Sensor (SL-PS -A57 P.W.B. Assembly) Removal .....	4-101

Lower Feeder Unit Paper Feed Clutch (PKCLL) / LF Clutch (DPKCL) Removal . . . . .	<b>4-102</b>
Lower Feeder Unit Paper Feeder Rolling / Separator Pad Removal . . . . .	<b>4-103</b>
Duplex Cover and Paper Guide Removals . . . . .	<b>4-104</b>
Duplex Side Cover Low (R) Removal . . . . .	<b>4-105</b>
Duplex Side Cover Low (L) Removal . . . . .	<b>4-106</b>
Duplex Cover Top (R) Removal . . . . .	<b>4-107</b>
Duplex Cover Top (L) Removal . . . . .	<b>4-108</b>
Duplex Cover Top (B) Assembly Removal . . . . .	<b>4-109</b>
Duplex Cover Top (C) Assembly Removal . . . . .	<b>4-111</b>
Duplex Cover Low (B) Assembly Removal . . . . .	<b>4-112</b>
Duplex Bottom Cover Assembly Removal . . . . .	<b>4-113</b>
Duplex Paper Guide RVS Unit Removal . . . . .	<b>4-115</b>
Duplex Paper Guide RVS IN Removal . . . . .	<b>4-117</b>
Duplex Paper Guide Bottom Removal . . . . .	<b>4-119</b>
Duplex Paper Top Assembly (D-Top Unit and D-Lower Unit) Removal . . . . .	<b>4-121</b>
Duplex Paper Guide Top Assembly Removal . . . . .	<b>4-123</b>
Duplex Print P.W.B. Removal . . . . .	<b>4-124</b>
Duplex Relay P.W.B. Removal . . . . .	<b>4-126</b>
Duplex Motor 1 Removal . . . . .	<b>4-128</b>
Duplex Motor 2 Removal . . . . .	<b>4-129</b>
Duplex Fan Motor Removal . . . . .	<b>4-131</b>
Duplex Solenoid (U) Assembly Removal . . . . .	<b>4-132</b>
Duplex Solenoid (L) Assembly Removal . . . . .	<b>4-133</b>
Duplex Interlock Switch (D-SW1, D-SW2) Removal . . . . .	<b>4-134</b>
Duplex Interlock Switch (D-SW3, D-SW4) Removal . . . . .	<b>4-135</b>
Duplex D Paper Sensor (PT5) Removal . . . . .	<b>4-136</b>
Duplex Paper Sensor Low (PT4) Removal . . . . .	<b>4-137</b>
<b>Locations . . . . .</b>	<b>5-1</b>
Printer . . . . .	<b>5-1</b>
Options . . . . .	<b>5-3</b>
Electronic Components . . . . .	<b>5-4</b>
Sensor Locations . . . . .	<b>5-4</b>
Printer Circuit Board Locations . . . . .	<b>5-6</b>
Fan/Motor Locations . . . . .	<b>5-8</b>
Solenoid/Clutch Locations . . . . .	<b>5-9</b>
Symbol and Part Name Table . . . . .	<b>5-11</b>
Wiring Diagram / Cable Harness Reference . . . . .	<b>5-13</b>
Controller RIP Card . . . . .	<b>5-15</b>
Main Engine (MCTL P.W.B.) Board . . . . .	<b>5-16</b>

IOD1 P.W.B. Board .....	5-17
IOD2 P.W.B. Board .....	5-18
Low Voltage Power Supply (LVPS) Board .....	5-19
High Voltage Unit (HVU) Board .....	5-20
Fuser Unit (LVPS) Board .....	5-21
Connector Locations for Options .....	5-22
Lower Feed Unit Option .....	5-22
Duplex Unit .....	5-23
Connector Pin Assignments .....	5-24
Location 1 .....	5-24
Location 2 .....	5-25
Location 3 .....	5-25
Location 4 .....	5-25
Location 5 .....	5-26
Location 6 .....	5-27
Location 7 .....	5-28
Location 8 .....	5-28
Location 9 .....	5-29
Location 10 .....	5-29
Location 11 .....	5-30
Location 12 .....	5-31
Location 13 .....	5-31
Location 14 .....	5-32
Location 15 .....	5-32
Location 16 .....	5-33
Location 17 .....	5-33
Location 18 .....	5-33
Location 19 .....	5-34
Location 20 .....	5-34
Location 21 .....	5-35
Location 22 .....	5-35
Location 23 .....	5-35
Location 24 .....	5-36
Location 25 .....	5-36
Location 26 .....	5-36
Location 27 .....	5-37
Location 28 .....	5-37
Location 29 .....	5-38
Location 30 .....	5-38
Location 31 .....	5-39
Location 32 .....	5-40
Location 33 .....	5-40
Location 34 .....	5-40

Location 35.....	5-41
Location 36.....	5-41
Location 37.....	5-42
Location 38.....	5-42
Location 39.....	5-43
Location 40.....	5-44
Location 41.....	5-44
Location 42.....	5-45
Printer Cables .....	5-46
Cable 1 Connector Assignments .....	5-46
Cable 2 Connector Assignments .....	5-46
Cable 3 Connector Assignments .....	5-47
Cable 4 Connector Assignments .....	5-48
Cable 5 Connector Assignments .....	5-49
Cable 6 Connector Assignments .....	5-49
Cable 7 Connector Assignments .....	5-49
Cable 8 Connector Assignments .....	5-50
Cable 9 Connector Assignments .....	5-50
Cable 10 Connector Assignments .....	5-50
Cable 11 Connector Assignments .....	5-51
Cable 12 Connector Assignments .....	5-51
Cable 13 Connector Assignments .....	5-51
<b>Preventive Maintenance .....</b>	<b>6-1</b>
Safety Inspection Guide .....	6-1
Service Precautions .....	6-1
Cleaning Procedures .....	6-1
Lubrication Specifications .....	6-2
Printer Supplies and Maintenance Schedules .....	6-3
Cleaning for Maintenance .....	6-4
<b>Parts Catalog .....</b>	<b>7-1</b>
How to Use this Parts Catalog .....	7-1
Assembly 1: .....	7-2
Assembly 2: .....	7-6
Assembly 3: .....	7-12
Assembly 4: .....	7-16
Assembly 5: Controller RIP Card .....	7-18
Assembly 6: Printer Cable Harness Sets .....	7-20
Assembly 7: Miscellaneous .....	7-22
Assembly 8: Lower Feed Unit .....	7-24
Assembly 9: Duplex Unit .....	7-28
<b>Index.....</b>	<b>I-1</b>





---

# Notices and Safety Information

---

## Laser Notices

**CAUTION:** The following laser warning labels may be affixed to this printer as shown:

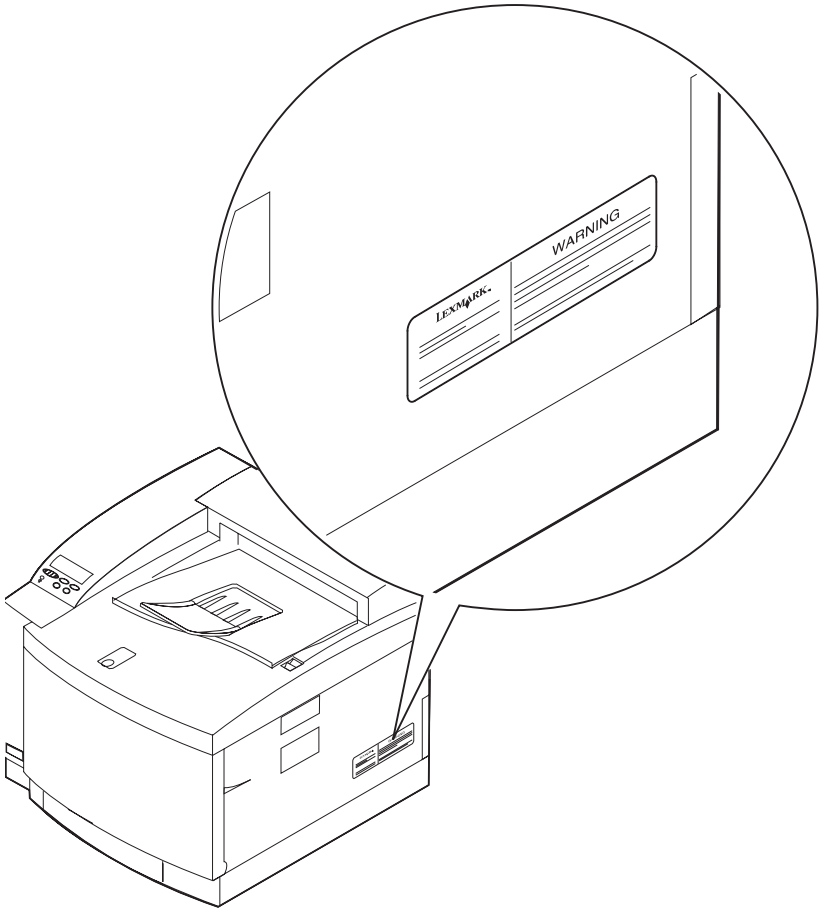

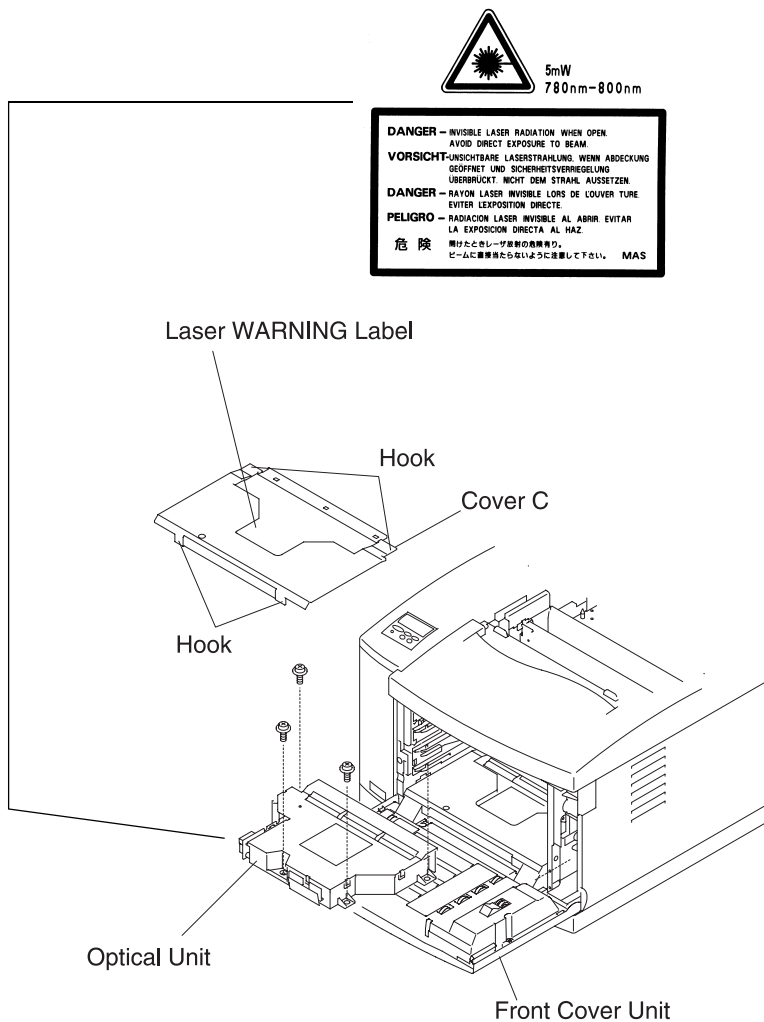

## Laser Notice

The printer is certified in the U.S. to conform to the requirements of DHHS 21 CFR Subchapter J for Class I (1) laser products, and elsewhere is certified as a Class I laser product conforming to the requirements of IEC 60825.

Class I laser products are not considered to be hazardous. The printer contains internally a Class IIIb (3b) laser that is nominally a 5 milliwatt gallium arsenide laser operating in the wavelength region of 770-795 nanometers. The laser system and printer are designed so there is never any human access to laser radiation above a Class I level during normal operation, user maintenance, or prescribed service condition.

---

## **Laser** *German*

Der Drucker erfüllt gemäß amtlicher Bestätigung der USA die Anforderungen der Bestimmung DHHS (Department of Health and Human Services) 21 CFR Teil J für Laserprodukte der Klasse I (1). In anderen Ländern gilt der Drucker als Laserprodukt der Klasse I, der die Anforderungen der IEC (International Electrotechnical Commission) 825 gemäß amtlicher Bestätigung erfüllt.

Laserprodukte der Klasse I gelten als unschädlich. Im Inneren des Druckers befindet sich ein Laser der Klasse IIIb (3b), bei dem es sich um einen Galliumarsenlaser mit 5 Milliwatt handelt, der Wellen der Länge 770-795 Nanometer ausstrahlt. Das Lasersystem und der Drucker sind so konzipiert, daß im Normalbetrieb, bei der Wartung durch den Benutzer oder bei ordnungsgemäßer Wartung durch den Kundendienst Laserbestrahlung, die die Klasse I übersteigen würde, Menschen keinesfalls erreicht.

---

## **Avis relatif à l'utilisation de laser** *French*

Pour les Etats-Unis : cette imprimante est certifiée conforme aux provisions DHHS 21 CFR alinéa J concernant les produits laser de Classe I (1). Pour les autres pays : cette imprimante répond aux normes IEC 825 relatives aux produits laser de Classe I.

Les produits laser de Classe I sont considérés comme des produits non dangereux. Cette imprimante est équipée d'un laser de Classe IIIb (3b) (arséniure de gallium d'une puissance nominale de 5 milliwatts) émettant sur des longueurs d'onde comprises entre 770 et 795 nanomètres. L'imprimante et son système laser sont conçus pour impossible, dans des conditions normales d'utilisation, d'entretien par l'utilisateur ou de révision, l'exposition à des rayonnements laser supérieurs à des rayonnements de Classe I.

---

## **Avvertenze sui prodotti laser** *Italian*

Questa stampante è certificata negli Stati Uniti per essere conforme ai requisiti del DHHS 21 CFR Sottocapitolo J per i prodotti laser di classe 1 ed è certificata negli altri Paesi come prodotto laser di classe 1 conforme ai requisiti della norma CEI 825.

I prodotti laser di classe non sono considerati pericolosi. La stampante contiene al suo interno un laser di classe IIIb (3b) all'arseniuro di gallio della potenza di 5mW che opera sulla lunghezza d'onda compresa tra 770 e 795 nanometri. Il sistema laser e la stampante sono stati progettati in modo tale che le persone a contatto con la stampante, durante il normale funzionamento, le operazioni di servizio o quelle di assistenza tecnica, non ricevano radiazioni laser superiori al livello della classe 1.

---

## **Avisos sobre el láser** *Spanish*

Se certifica que, en los EE.UU., esta impresora cumple los requisitos para los productos láser de Clase I (1) establecidos en el subcapítulo J de la norma CFR 21 del DHHS (Departamento de Sanidad y Servicios) y, en los demás países, reúne todas las condiciones expuestas en la norma IEC 825 para productos láser de Clase I (1).

Los productos láser de Clase I no se consideran peligrosos. La impresora contiene en su interior un láser de Clase IIIb (3b) de arseniuro de galio de funcionamiento nominal a 5 milivatios en una longitud de onda de 770 a 795 nanómetros. El sistema láser y la impresora están diseñados de forma que ninguna persona pueda verse afectada por ningún tipo de radiación láser superior al nivel de la Clase I durante su uso normal, el mantenimiento realizado por el usuario o cualquier otra situación de servicio técnico.

---

## **Declaração sobre Laser** *Portugese*

A impressora está certificada nos E.U.A. em conformidade com os requisitos da regulamentação DHHS 21 CFR Subcapítulo J para a Classe I (1) de produtos laser. Em outros locais, está certificada como um produto laser da Classe I, em conformidade com os requisitos da norma IEC 825.

Os produtos laser da Classe I não são considerados perigosos. Internamente, a impressora contém um produto laser da Classe IIIb (3b), designado laser de arseneto de potássio, de 5 milliwatts, operando numa faixa de comprimento de onda entre 770 e 795 nanómetros. O sistema e a impressora laser foram concebidos de forma a nunca existir qualquer possibilidade de acesso humano a radiação laser superior a um nível de Classe I durante a operação normal, a manutenção feita pelo utilizador ou condições de assistência prescritas.

---

## **Laserinformatie** *Dutch*

De printer voldoet aan de eisen die gesteld worden aan een laserprodukt van klasse I. Voor de Verenigde Staten zijn deze eisen vastgelegd in DHHS 21 CFR Subchapter J, voor andere landen in IEC 825.

Laserprodukten van klasse I worden niet als ongevaarlijk aangemerkt. De printer is voorzien van een laser van klasse IIIB (3b), dat wil zeggen een gallium arsenide-laser van 5 milliwatt met een golflengte van 770-795 nanometer. Het lasergeedeelte en de printer zijn zo ontworpen dat bij normaal gebruik, bij onderhoud of reparatie conform de voorschriften, nooit blootstelling mogelijk is aan laserstraling boven een niveau zoals voorgeschreven is voor klasse 1.

---

## **Lasermeddelelse** *Danish*

Printeren er godkendt som et Klasse I-laserprodukt, i overensstemmelse med kravene i IEC 825.

Klasse I-laserprodukter betragtes ikke som farlige. Printeren indeholder internt en Klasse IIIB (3b)-laser, der nominelt er en 5 milliwatt galliumarsenid laser, som arbejder på bølglængdeområdet 770-795 nanometer. Lasersystemet og printeren er udformet således, at mennesker aldrig udsættes for en laserstråling over Klasse I-niveau ved normal drift, brugervedligeholdelse eller obligatoriske servicebetingelser.

---

## Huomautus laserlaitteesta *Finnish*

Tämä kirjoitin on Yhdysvalloissa luokan I (1) laserlaitteiden DHHS 21 CFR Subchapter J -määrityksen mukainen ja muualla luokan I laserlaitteiden IEC 825 -määrityksen mukainen.

Luokan I laserlaitteiden ei katsota olevan vaarallisia käyttäjälle. Kirjoittimessa on sisäinen luokan IIIb (3b) 5 milliwatin galliumarsenidilaser, joka toimii aaltoalueella 770 - 795 nanometriä. Laserjärjestelmä ja kirjoitin on suunniteltu siten, että käyttäjä ei altistu luokan I määrityksiä voimakkaammalle säteilylle kirjoittimen normaalin toiminnan, käyttäjän tekemien huoltotoimien tai muiden huoltotoimien yhteydessä.

### LUOKAN 1 LASERLAITE

**VAROITUS!** Laitteen käyttäminen muulla kuin tässä käyttöohjeessa mainitulla tavalla saattaa altistaa käyttäjän turvallisuusluokan 1 ylittävälle näkymättömälle lasersäteilylle.

### KLASS 1 LASER APPARAT

**VARNING!** Om apparaten används på annat sätt än i denna bruksanvisning specificerats, kan användaren utsättas för osynlig laserstrålning, som överskrider gränsen för laserklass 1.

**VARO!** Avattaessa ja suojalukitus ohitettaessa olet alttiina näkymättömälle lasersäteilylle. Älä katso säteeseen.

**VARNING!** Osynlig laserstrålning när denna del är öppnad och spärren är urkopplad. Betrakta ej strålen.

---

## **Laser-notis** *Swedish*

Denna skrivare är i USA certifierad att motsvara kraven i DHHS 21 CFR, underparagraf J för laserprodukter av Klass I (1). I andra länder uppfyller skrivaren kraven för laserprodukter av Klass I enligt kraven i IEC 825.

Laserprodukter i Klass I anses ej hälsovådliga. Skrivaren har en inbyggd laser av Klass IIIb (3b) som består av en laserenhet av gallium-arsenid på 5 milliwatt som arbetar i våglängdsområdet 770-795 nanometer. Lasersystemet och skrivaren är utformade så att det aldrig finns risk för att någon person utsätts för laserstrålning över Klass I-nivå vid normal användning, underhåll som utförs av användaren eller annan föreskriven serviceåtgärd.

---

## **Laser-melding** *Norwegian*

Skriveren er godkjent i USA etter kravene i DHHS 21 CFR, underkapittel J, for klasse I (1) laserprodukter, og er i andre land godkjent som et Klasse I-laserprodukt i samsvar med kravene i IEC 825.

Klasse I-laserprodukter er ikke å betrakte som farlige. Skriveren inneholder internt en klasse IIIb (3b)-laser, som består av en gallium-arsenlaserenhet som avgir stråling i bølglengdeområdet 770-795 nanometer. Lasersystemet og skriveren er utformet slik at personer aldri utsettes for laserstråling ut over klasse I-nivå under vanlig bruk, vedlikehold som utføres av brukeren, eller foreskrevne serviceoperasjoner.



---

## **Avís sobre el Làser** *Catalàn*

Segons ha estat certificat als Estats Units, aquesta impressora compleix els requisits de DHHS 21 CFR, apartat J, pels productes làser de classe I (1), i segons ha estat certificat en altres llocs, és un producte làser de classe I que compleix els requisits d'IEC 825.

Els productes làser de classe I no es consideren perillosos. Aquesta impressora conté un làser de classe IIIb (3b) d'arseniür de gal.li, nominalment de 5 mil.liwats, i funciona a la regió de longitud d'ona de 770-795 nanòmetres. El sistema làser i la impressora han sigut concebuts de manera que mai hi hagi exposició a la radiació làser per sobre d'un nivell de classe I durant una operació normal, durant les tasques de manteniment d'usuari ni durant els serveis que satisfacin les condicions prescrites.

---

## Japanese Laser Notice

レーザーに関するお知らせ

このプリンターは、米国ではDHHS 21 CFRサブチャプターJのクラスI (1)の基準を満たしたレーザー製品であることが証明されています。また米国以外ではIEC 825の基準を満たしたクラスIのレーザー製品であることが証明されています。

クラスIのレーザー製品には危険性はないと考えられています。このプリンターはクラスIII b (3 b)のレーザーを内蔵しています。このレーザーは、波長が770 ~ 795ナノメートルの範囲で、通常5ミリワットのカリウム砒化物を放射するレーザーです。このレーザーシステムとプリンターは、通常の操作、ユーザのメンテナンス、規定された修理においては、人体がクラスIのレベル以上のレーザー放射に晒されることのないよう設計されています。

---

## Chinese Laser Notice

注意：

本打印机被美国认证合乎 DHHS 21 CFR Subchapter I 对分类 I (1) 激光产品的标准，而在其他地区则被认证合乎 IEC 825 的标准。

分类 I 激光产品一般认为不具危险性，本打印机内部含有分类 IIIb (3b) 的激光，在操作过程中会产生 5 毫瓦含镓及砷的微量激光，其波长范围在 770-795 nm 之间。本激光系统及打印机的设计，在一般操作、使用者维护或规定内的维修情况下，不会使人体接触分类 I 以上等级的辐射。

---

## Korean Laser Notice

본프린터는 1등급 레이저 제품들에 대한 DHHS 21 CFR Subchapter 3의 규정을 준수하고 있음을 미국에서 인증받았으며, 그외의 나라에서도 IEC 825 규정을 준수하는 1등급 레이저 제품으로서 인증을 받았습니다.

1등급 레이저 제품들은 안전한 것으로 간주됩니다. 본 프린터는 5 밀리와트 갈륨 아르세나이드 레이저로서 770-795 나노미터의 파장대에서 활동하는 Class III (3b) 레이저를 내부에 갖고 있습니다. 본 레이저 시스템과 프린터는 정상 작동 중이나 유지 보수 중 또는 규정된 서비스 상태에서 상기의 Class I 수준의 레이저 방출에 사람이 절대 접근할 수 없도록 설계되어 있습니다.

---

## Safety Information

- This product is designed, tested and approved to meet strict global safety standards with the use of specific Lexmark components. The safety features of some parts may not always be obvious. Lexmark is not responsible for the use of other replacement parts.
- The maintenance information for this product has been prepared for use by a professional service person and is not intended to be used by others.
- There may be an increased risk of electric shock and personal injury during disassembly and servicing of this product. Professional service personnel should understand this and take necessary precautions.

---

## Consignes de Sécurité

- Ce produit a été conçu, testé et approuvé pour respecter les normes strictes de sécurité globale lors de l'utilisation de composants Lexmark spécifiques. Les caractéristiques de sécurité de certains éléments ne sont pas toujours évidentes. Lexmark ne peut être tenu responsable de l'utilisation d'autres pièces de rechange.
- Les consignes d'entretien et de réparation de ce produit s'adressent uniquement à un personnel de maintenance qualifié.
- Le démontage et l'entretien de ce produit pouvant présenter certains risques électriques, le personnel d'entretien qualifié devra prendre toutes les précautions nécessaires.

---

## Norme di sicurezza

- Il prodotto è stato progettato, testato e approvato in conformità a severi standard di sicurezza e per l'utilizzo con componenti Lexmark specifici. Le caratteristiche di sicurezza di alcune parti non sempre sono di immediata comprensione. Lexmark non è responsabile per l'utilizzo di parti di ricambio di altri produttori.
- Le informazioni riguardanti la manutenzione di questo prodotto sono indirizzate soltanto al personale di assistenza autorizzato.
- Durante lo smontaggio e la manutenzione di questo prodotto, il rischio di subire scosse elettriche e danni alla persona è più elevato. Il personale di assistenza autorizzato, deve, quindi, adottare le precauzioni necessarie.

---

## Sicherheitshinweise

- Dieses Produkt und die zugehörigen Komponenten wurden entworfen und getestet, um beim Einsatz die weltweit gültigen Sicherheitsanforderungen zu erfüllen. Die sicherheitsrelevanten Funktionen der Bauteile und Optionen sind nicht immer offensichtlich. Sofern Teile eingesetzt werden, die nicht von Lexmark sind, wird von Lexmark keinerlei Verantwortung oder Haftung für dieses Produkt übernommen.
- Die Wartungsinformationen für dieses Produkt sind ausschließlich für die Verwendung durch einen Wartungsfachmann bestimmt.
- Während des Auseinandernehmens und der Wartung des Geräts besteht ein zusätzliches Risiko eines elektrischen Schlags und körperlicher Verletzung. Das zuständige Fachpersonal sollte entsprechende Vorsichtsmaßnahmen treffen.

---

## Pautas de Seguridad

- Este producto se ha diseñado, verificado y aprobado para cumplir los más estrictos estándares de seguridad global usando los componentes específicos de Lexmark. Puede que las características de seguridad de algunas piezas no sean siempre evidentes. Lexmark no se hace responsable del uso de otras piezas de recambio.
- La información sobre el mantenimiento de este producto está dirigida exclusivamente al personal cualificado de mantenimiento.
- Existe mayor riesgo de descarga eléctrica y de daños personales durante el desmontaje y la reparación de la máquina. El personal cualificado debe ser consciente de este peligro y tomar las precauciones necesarias.

---

## Informações de Segurança

- Este produto foi concebido, testado e aprovado para satisfazer os padrões globais de segurança na utilização de componentes específicos da Lexmark. As funções de segurança de alguns dos componentes podem não ser sempre óbvias. A Lexmark não é responsável pela utilização de outros componentes de substituição.
- As informações de segurança relativas a este produto destinam-se a profissionais destes serviços e não devem ser utilizadas por outras pessoas.
- Risco de choques eléctricos e ferimentos graves durante a desmontagem e manutenção deste produto. Os profissionais destes serviços devem estar avisados deste facto e tomar os cuidados necessários.

---

## Informació de Seguretat

- Aquest producte està dissenyat, comprovat i aprovat per tal d'acomplir les estrictes normes de seguretat globals amb la utilització de components específics de Lexmark. Les característiques de seguretat d'algunes peces pot ser que no sempre siguin òbvies. Lexmark no es responsabilitza de l'ús d'altres peces de recanvi.
- La informació pel manteniment d'aquest producte està orientada exclusivament a professionals i no està destinada a ningú que no ho sigui.
- El risc de xoc elèctric i de danys personals pot augmentar durant el procés de desmuntatge i de servei d'aquest producte. El personal professional ha d'estar-ne assabentat i prendre les mesures convenients.

## 안전 사항

- 본 제품에 관한 유지 보수 설명서는 전문 서비스 기술자 용으로 작성된 것이므로 비 전문가가 사용할 수 없습니다.
- 본제품을 해체하거나 정비할 경우 전기적인 충격을 받거나 상처를 입을 위험이 커집니다. 전문 서비스 기술자는 이 사실을 숙지하고 필요한 예방 조치를 취하도록 하십시오.
- 일부 부품의 안전성은 항상 보장되지 않습니다. 따라서, 교체 부품은 원래 부품과 같거나 동등한 특성을 가진 제품을 사용하여야합니다.

## 安全资讯

- 本产品的维护资讯仅供专业服务人员使用，而非针对一般使用者。
- 本产品在拆卸、维修的时候，遭受电击或人员受伤的危险性会增高，专业服务人员对这点必须有所了解，并采取必要的预防措施。
- 有些零件的安全功能可能不明显。因此，所替换零件的性能一定要与原有的零件一致。





---

## Preface

This manual and contains maintenance procedures for service personnel. It is divided into the following chapters:

1. **General Information** contains a general description of the printer and the maintenance approach used to repair it. Special tools and test equipment are listed in this chapter, as well as general environmental and safety instructions.
2. **Diagnostic Information** contains an error indicator table, symptom tables, and service checks used to isolate failing field replaceable units (FRUs).
3. **Diagnostic Aids** contains tests and checks used to locate or repeat symptoms of printer problems.
4. **Repair Information** provides instructions for making printer adjustments and removing and installing FRUs.
5. **Connector Locations** uses illustrations to identify the connector locations and test points on the printer.
6. **Preventive Maintenance** contains the lubrication specifications and recommendations to prevent problems.
7. **Parts Catalog** contains illustrations and part numbers for individual FRUs.

---

# 1. General Information

Your Lexmark™ C720 color laser printer is the ideal printer for presentations, business graphics, line art, and text. The C720 uses laser diode electrophotographic technology to deliver remarkable quality print images and text. The C720 can be used as a shared network or desktop printer.

---

## Maintenance Approach

The diagnostic information in this manual leads you to the correct field replaceable unit (FRU) or part. Use the error code charts, symptom index, and service checks to determine the symptom and repair the failure. See **“Diagnostic Information” on page 2-1**, for location of each section. You may find that the removals in the Repair Information chapter will help you identify parts. After you complete the repair, perform tests as needed to verify the repair.

---

## Tools Required for Service

The removal and adjustment procedures described in this manual require the following tools and equipment:

- Analog volt ohmmeter (a digital volt ohmmeter may also be used)
- Flat-blade screwdrivers
- Needle nose pliers
- #1 Phillips screwdriver
- #2 Phillips screwdriver
- Slotted screwdriver #1
- Slotted clock screwdriver #1
- Tweezers, C-ring pliers

When you make voltage readings, always use frame ground unless another ground is specified.

---

## Serial Number

Look for the label on the rear cover of your printer for serial number information. The serial number is also listed in the menu settings page and can be printed from the utilities menu.

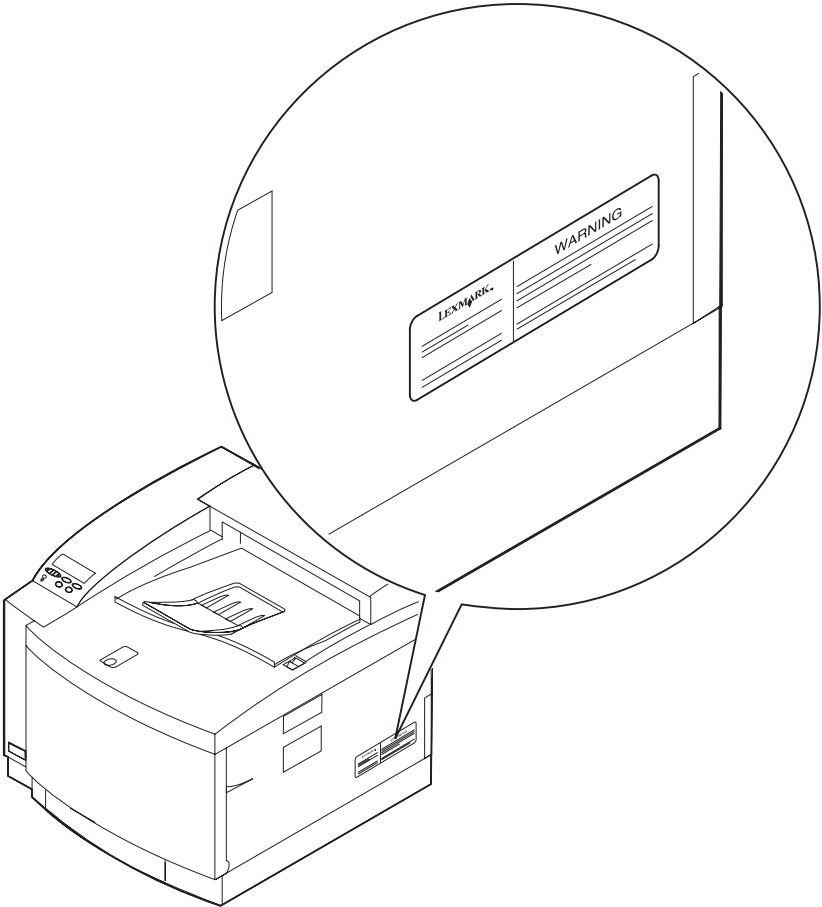

---

## Acronyms

ASIC	Application-Specific Integrated Circuit
CS	Customer Ordered
CSU	Customer Setup
DRAM	Dynamic Random Access Memory
EEPROM	Electrically Erasable Programmable Read-Only Memory
EP	Electrophotographic Process
ESD	Electrostatic Discharge
FRU	Field Replaceable Unit
HVPS	High Voltage Power Supply
LAN	Local Area Network
LASER	Light Amplification by Stimulated Emission of Radiation
LCD	Liquid Crystal Display
LED	Light-Emitting Diode
LVPS	Low Voltage Power Supply
NVRAM	Nonvolatile Random Access Memory
OEM	Original Equipment Manufacturer
PICS	Problem Isolation Charts
PIXEL	Picture Element
POR	Power-On Reset
POST	Power-On Self Test
PQET	Print Quality Enhancement Technology
RIP	Raster Image Processor
ROS	Read-Only Storage
SRAM	Static Random Access Memory
UPR	Used Parts Replacement
VAC	Volts alternating current
VDC	Volts direct current

## Standard Features

### Printer (Main)

Feature	Description
Print method	Semiconductor laser and electrophotography
Print addressability	600 x 600 dpi 2400IQ
Print speed	Cassette feed and continuous print:
Monochrome	<ul style="list-style-type: none"> <li>• 24 sheets per minute (letter size)</li> </ul>
2 (two) color	<ul style="list-style-type: none"> <li>• 12 sheets per minute (letter size)</li> </ul>
4 (four) color	<ul style="list-style-type: none"> <li>• 6 sheets per minute (letter size)</li> </ul>
Duplex print speed	<ul style="list-style-type: none"> <li>• Maximum mono / black print speed: 16 sides / 8 PPM</li> <li>• Maximum 4 color print speed: 6 sides / 3 ppm</li> <li>• Combination color / mono (one side color, other side mono) is no slower than color speed (4 ppm) and no faster than mono speed (8 ppm).</li> </ul>
Printer warm-up time	240 seconds (maximum)
Acoustic noise	<ul style="list-style-type: none"> <li>• Standby 45 dBA</li> <li>• Operation 51 dBA</li> </ul>
Fonts	<ul style="list-style-type: none"> <li>• 240 resident scalable fonts: PostScript 3 emulation with 156 scalable fonts 84 PCL 6 emulation scalable fonts 2 bit mapped fonts</li> <li>• 2 PCL 6 bitmap fonts: Line printer 16 POSTNET barcode</li> <li>• World class international font support: 83 symbol sets in the PCL 6 emulation to support all the languages that use these characters.</li> </ul> <p><b>Note:</b> Refer to the printer operator panel to find the symbol sets supported by each font.</p>

Feature	Description
Paper input	<p>Easy loading paper trays (no corner bucklers)</p> <p>Tray 1 -</p> <ul style="list-style-type: none"> <li>• 250 sheet drawer supporting A4, letter, based on 20 lb paper</li> <li>• 50 transparencies supporting A4, letter</li> <li>• 80 label sheets</li> <li>• 15 envelopes</li> <li>• 50 card stock sheets</li> <li>• Optional 250 sheet B5 and legal input drawer (used in Tray 1 position) provides the ability to print to a maximum of 8.5 x 14 in. (216 x 356 mm)</li> </ul>
Optional 500 sheet input drawers	<p>Tray 2 -</p> <p>500 sheet input drawer installs under the printer supporting letter, A4, and letter</p>
Paper output	Full sensing top output bin: 250 sheets (face down)
Paper sizes supported	<p>A4, letter, legal, executive, transparencies, label and envelope</p> <p><b>Note:</b> Print media other than paper, such as thick stock, label, transparency, or envelopes should use the upper feed (Tray 1) only.</p>
Printer memory	<p>Industry standard on 32 bit 100 MHz 100 pin SDRAM DIMMs</p> <p><b>Note:</b> Some printer models may ship with more memory. When a duplex unit is installed, 64MB is the recommended minimum printer memory.</p>
Interface	<ul style="list-style-type: none"> <li>• High speed parallel interface (IEEE 1284 standard, nibble byte and ECP modes)</li> </ul> <p>Optional interfaces:</p> <ul style="list-style-type: none"> <li>• Serial support for RS-232 and RS-422 with the optional Tri-Port interface card</li> <li>• Infrared</li> <li>• SCSI</li> <li>• LocalTalk</li> <li>• Internal Solution Ports (ISP) adapter</li> <li>• USB and 1284-A parallel</li> </ul>

Feature	Description
Internal solutions ports	<ul style="list-style-type: none"> <li>• 1 port for tri-port adapter, serial port adapter, or additional parallel port adapter</li> <li>• 3 memory connectors</li> </ul>
Operating Systems	<p>The 5024 is compatible with applications running under the following operating systems for either local or network connections:</p> <ul style="list-style-type: none"> <li>• Apple Macintosh Operating System or higher</li> </ul> <p><b>Note:</b> The C720 printer with an optional Tri-Port adapter, Ethernet (EtherTalk) or Token-Ring (TokenTalk) MarkNet N2000 Internal Print Server installed supports the Apple operating system. The software applications that operate with most Apple LaserWriter printers will generally operate with the C720. The Macintosh 128, 512, and 52e computers are not supported.</p> <ul style="list-style-type: none"> <li>• Microsoft Windows 3.1 or higher</li> <li>• Microsoft Windows for Workgroups 3.11 or higher</li> <li>• Microsoft Windows 95 4.00.950 or higher</li> <li>• Microsoft Windows 98</li> <li>• Microsoft Windows Me</li> <li>• Microsoft Windows NT 3.51</li> <li>• Microsoft Windows NT 4.00 or higher</li> <li>• Microsoft Windows 2000 <ul style="list-style-type: none"> <li>• MS-DOS or IBM DOS 5.0 or higher</li> <li>• IBM OS/2 2.1 or higher</li> </ul> </li> <li>– Virtually any platform supporting TCP/IP</li> <li>– IBM AS/400 System with TCP/IP</li> <li>– IBM Application System/400 with Operating System/400 Version 3 Release 1 or later utilizing OS/400 Host Print Transform function.</li> </ul> <p><b>Note:</b> Other IBM emulators may support this printer. Refer to specific emulator product information for details.</p> <p>UNIX Systems:</p> <ul style="list-style-type: none"> <li>• Digital UNIX 4.0</li> <li>• HP-UX 10.x, 11.x</li> <li>• IBM AIX 4.x</li> <li>• Red Hat Linux 5.2, 6.0 or later</li> </ul>



Feature	Description
Operating Systems (continued)	<ul style="list-style-type: none"> <li>• SCO OpenServer 5.x</li> <li>• SCO UnixWare 2.1.x, 7</li> <li>• SCI IRIX 6.x</li> <li>• Sun Solaris x86 2.5, 2.6, 7, 8</li> <li>• Sun Solaris 2.5, 2.6, 7, 8</li> <li>• SuSE 6.1 Linux or later</li> <li>• TurboLinux Workstation 3.6 or later</li> </ul>
Printer Software	<p>MarkVision™ utility lets you manage your printer from your computer. The WW MarkVision / Driver CD ROM contains:</p> <ul style="list-style-type: none"> <li>• Drivers and MarkVision in English, French, German, Italian, Spanish, Brazilian Portuguese</li> <li>• Drivers and MarkVision for Windows 95/98/Me/NT 4.0/2000 and drivers only for Macintosh in Japanese, Simplified Chinese and Traditional Chinese</li> <li>• Windows 95/98/Me PCL 6 Lexmark printer drivers (C720)</li> <li>• Windows 95/98/Me PostScript 3 Lexmark printer drivers (C720)</li> <li>• Windows NT 4.0 PCL 6 Lexmark printer drivers (C720)</li> <li>• Windows NT 4.0 PostScript 3 Lexmark printer drivers (C720)</li> <li>• Windows 2000 PCL 6 Lexmark printer drivers (C720)</li> <li>• Windows 2000 PostScript 3 Lexmark printer drivers (C720)</li> <li>• Windows 3.1x Interwin Network Printer Utility</li> <li>• MarkVision for Windows 95/98/Me and Windows NT 4.0 and Windows 2000</li> </ul>

Feature	Description
Printer software (continued)	<ul style="list-style-type: none"> <li>• MarkVision Professional</li> <li>• AIX colon files (release 4.x)</li> <li>• UNIX print drivers for Solaris</li> <li>• Apple Macintosh (PostScript PPD files and Quark Printer Definition Files (PDFs))</li> <li>• MarkVision for Macintosh support</li> <li>• Screen Fonts</li> <li>• Font Vision Utility</li> <li>• Online Registration via the web or printed hardcopy</li> <li>• Softcopy documentation:               <ul style="list-style-type: none"> <li>– MarkVision and MarkVision Professional documentation</li> <li>– MarkNet print server documentation</li> <li>– Printer Technical Reference</li> <li>– Card Stock and Label Guide</li> </ul> </li> </ul>
Power supply	<ul style="list-style-type: none"> <li>• AC 120 +/- 10% Volts</li> <li>• AC 220 to 240 ± 10% Volts</li> </ul>
Temperature	0° to 35°C (32° to 95°F)
Controller	Lexmark controller (high performance)
RIP page storage	Hard disk option can be partitioned for intermediate RIP page storage.
Printer management software	MarkVision for network and/or desktop printer management

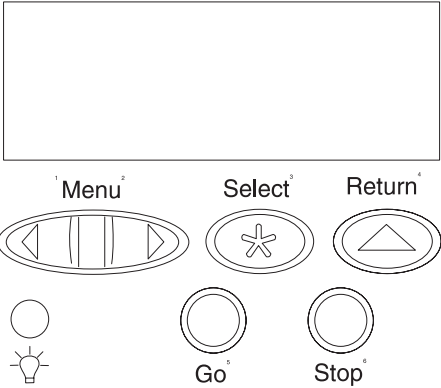
Feature	Description
Operator panel	<p>Front cover mounted operator panel for menus</p> 
Dimensions	<ul style="list-style-type: none"> <li>• Printer <ul style="list-style-type: none"> <li>– H 410 mm (16.1 in.)</li> <li>– W 500 mm (19.7 in.)</li> <li>– D 520 mm (20.5 in.)</li> </ul> </li> <li>• Printer with optional drawer unit <ul style="list-style-type: none"> <li>– H 555 mm (21.9 in.)</li> <li>– W 500 mm (19.7 in.)</li> <li>– D 520 mm (20.5 in.)</li> </ul> </li> <li>• Printer with optional drawer unit and duplex unit <ul style="list-style-type: none"> <li>– H 605 mm (23.8 in.)</li> <li>– W 500 mm (19.7 in.)</li> <li>– D 605 mm (23.8 in.)</li> </ul> </li> </ul>
Weight	<ul style="list-style-type: none"> <li>• Printer (with supplies installed) - 86 lbs</li> <li>• Duplex unit - 21 lbs</li> <li>• Optional 500 drawer - 19 lbs</li> <li>• Complete system - 126 lbs</li> </ul>
Paper feeding system	Pickup roller + separation pad
Image forming	Belt cartridge
PC belt	Organic photoconductor (OPC)
Charging system	Charger unit / corona wire
Exposure system	Laser diode + polygon mirror scanning

## 5024-001

<b>Feature</b>	<b>Description</b>
Development	Toner cartridge (CMYK)
Transferring of image	Transfer drum
Cleaning system	Blade/brush system
2nd transfer to paper	Roller transfer system
Separating system	Paper discharger / corona
Fusing system	Heat roller fusing system
Paper exit system	Top output bin: 250 sheets face down  <b>Note:</b> Output capacity is determined by output tray full sensor.

## Printer Options

Option	Description
Lower Feed Unit	Drawer unit with one (1) 500-sheet tray installed underneath the printer.
Duplex unit	Provides two sided color or monochrome printing
Memory	Maximum usable memory: 384MB.
Hard disk option	2.5-inch hard disk to store fonts, forms, job statistics, and spooled jobs (4GB limit)
MarkNet™ N2001e internal print servers	<p>Internal print servers available to support the following topologies:</p> <ul style="list-style-type: none"> <li>• Ethernet 10BaseT and 10Base2</li> <li>• Ethernet 10/100BaseTX</li> <li>• Token-Ring (connects the printer to a Token-Ring network via DB9 or RJ45)</li> </ul>
Tri-port interface card	<p>Provides support for the following interfaces:</p> <ul style="list-style-type: none"> <li>• Serial RS-232C/RS-422A (which can also be configured to support a class 1 fax modem)</li> <li>• High speed Infrared local connections</li> <li>• LocalTalk network connection</li> </ul>
Parallel /USB port interface card	IEEE 1284 adapter, provides additional parallel and USB port.
Infrared adapter	For use with the tri-port adapter; receives infrared beam from an IrDA-compatible workstation.
Serial interface adapter	Converts the printer parallel port to a serial port.
Parallel cable	<ul style="list-style-type: none"> <li>• High speed bidirectional 10-foot and 20-foot 1284-B parallel cables 6</li> <li>• 9.8-foot 1284 A-C parallel cable.</li> </ul>

# Printer Identification

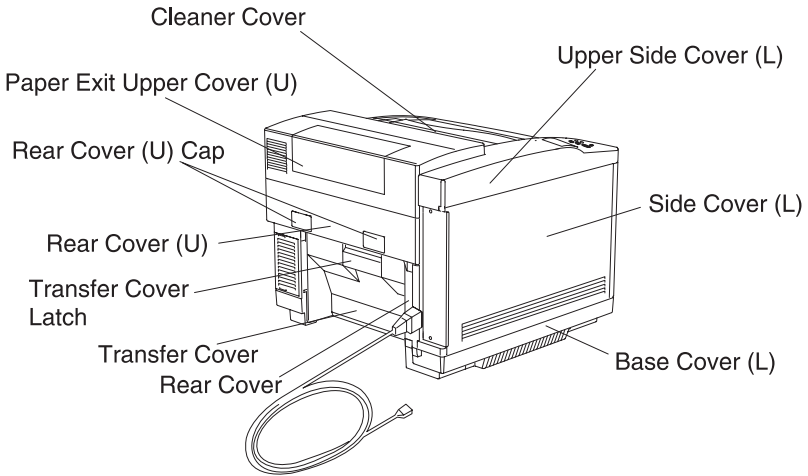
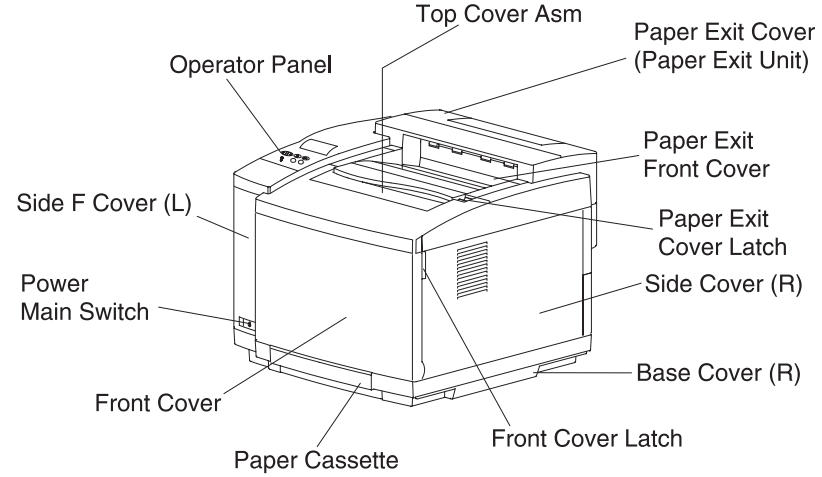

# Options Identification

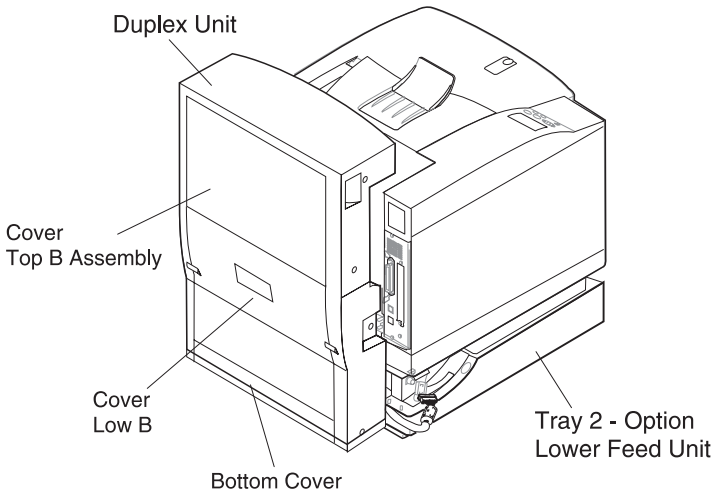
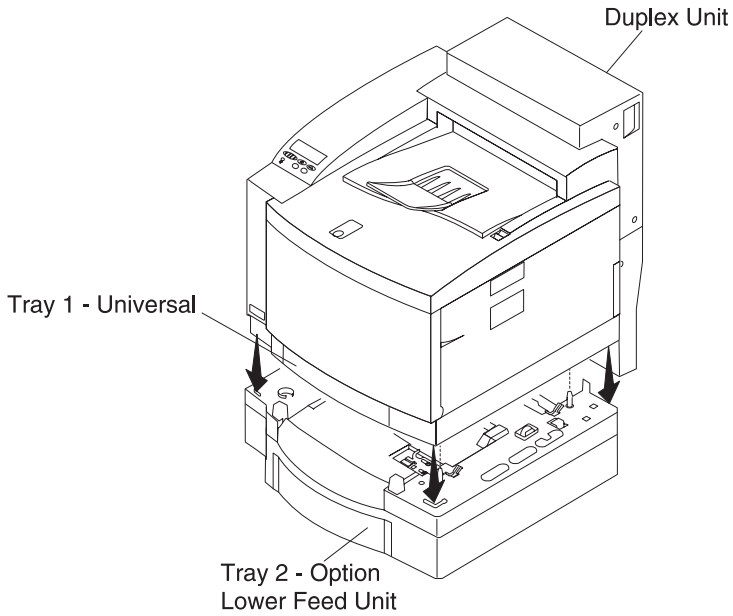

# Printer Theory of Operation

The following diagram shows the major parts of the printer and paper path.

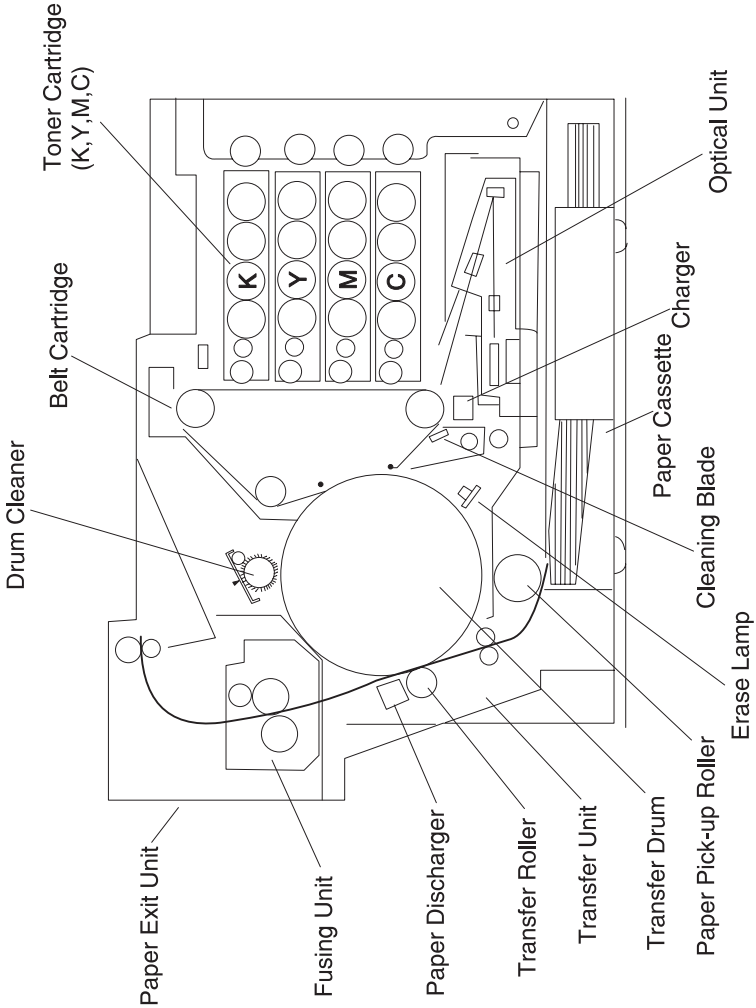



---

## Printer Systems Description

See the illustration “**Printer Component Systems**” on page 1-17, for more information.

### Basic Principles of Color Printing

Color printing is made through the subtractive process of combining the three primary colors, yellow, magenta, and cyan.

### Mechanical and Electrical Structures

The 5024 color laser printer consists of five engineering systems: print, transfer, optical, paper transport, and control system.

#### Print System

The print system consists of six functional parts located around the OPC belt and forms a toner image on the OPC belt.

Charge

Expose

Develop

First transfer

Discharge

Clean

#### Transfer System

The transfer system consists of three functional parts that transfers the toner image formed on the transfer drum to paper.

Transfer drum

Second transfer

Drum cleaner

## **Optical System**

The optical system consists of two functional parts that forms an electrostatic latent image on the OPC belt using a laser light.

Optical unit

Scanner motor (SCM)

## **Paper Transport System**

The paper transport system consists of five functional parts that picks up paper from the paper cassette, separates the transported paper from the transfer drum, and exits it from the printer after fusing the toner image on the paper.

Paper cassette

Transport

Paper discharge

Fuser

Paper exit

## **Control System**

The control system consists of four control parts and runs the printer by processing the interface signals transmitted from the computer and the other printer systems such as the print, transfer, optical, and transport system.

Sequence control

Laser control

Fusing temperature control

Interface control



## Basic Process of Color Printing

1. The 5024 printer has a toner cartridge for each color — yellow, magenta, cyan, and black.
2. The toner image is developed with the primary colors and then transferred to the transfer drum for the color combination.
3. The toner image formed on the transfer drum is transferred to paper.
4. The toner is fused to the paper by the thermal fuser unit.

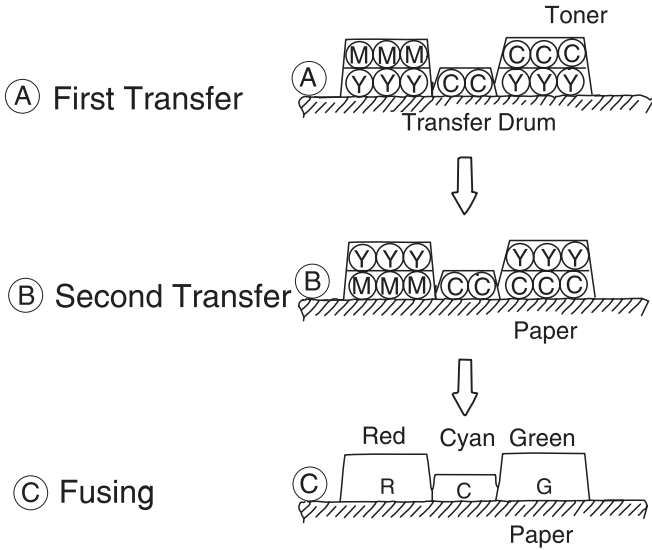
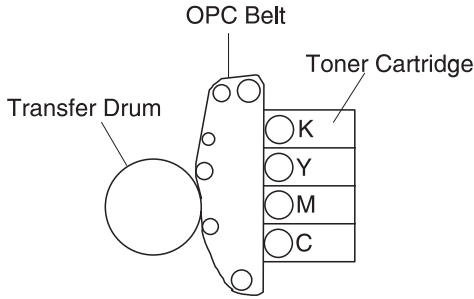

## Print System and Transfer System

This illustration shows the basic structure of the print system having the OPC belt as a main function, and the transfer system including the transfer drum. A color print is accomplished by actuating each process in the print system and the transfer system.

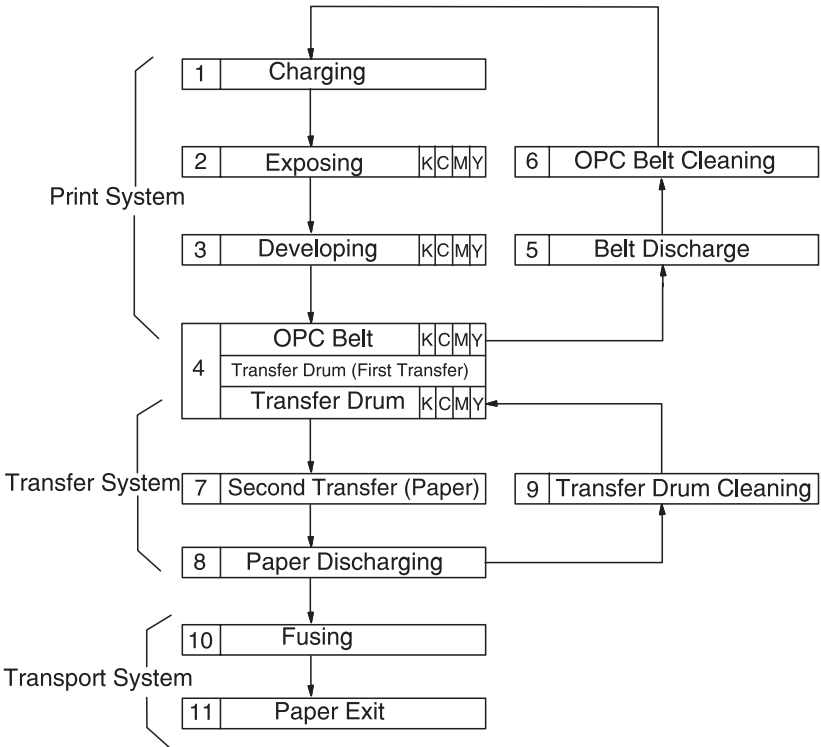

## Structure of OPC Belt (Photo Developer Cartridge)

The OPC belt consists of a surface layer having an optical photoconductor (OPC) of organic material, the inner layer consists of an insulator material (PET), and the aluminum deposit layer in between. The OPC belt is a main part of the print system.

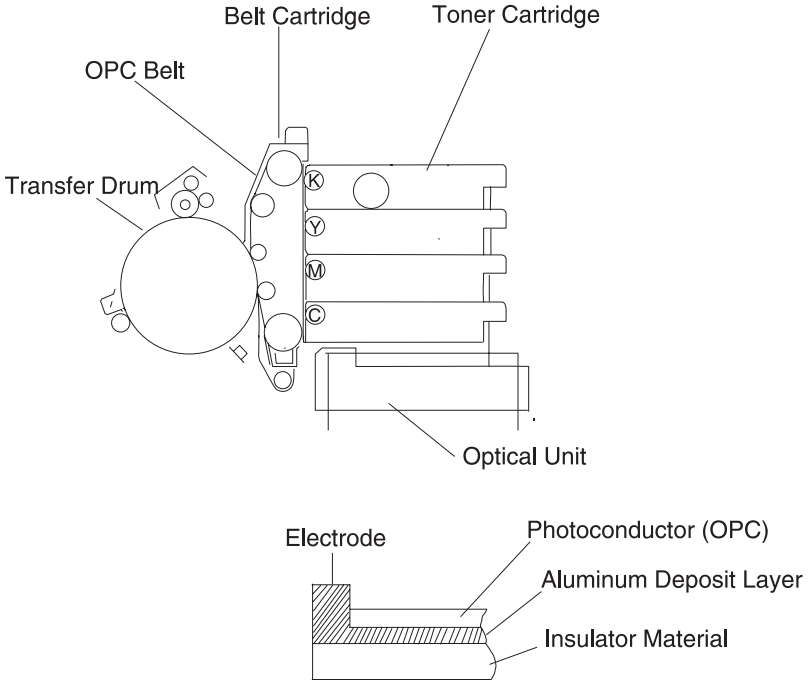

## Basic Structure of the Print System

1. The print system process consists of the following:
  - a. The OPC belt is biased to the voltage  $-CBV(V)$  by the power supply  $CBV$ .
  - b. Negative high voltage is applied to the charger unit by the power supply  $CHV$ , and the corona is generated as a result.
  - c. The developer roller on the toner cartridge is biased to  $-DBV(V)$  by the power supply  $DBV$ .
  - d. Frame potential of the transfer drum is  $GND$ .

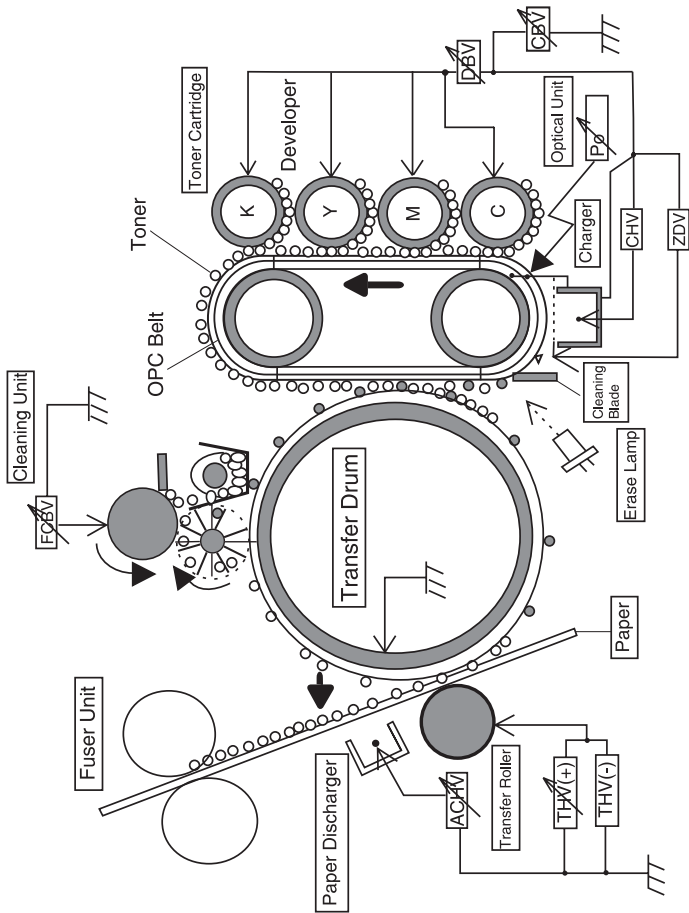

2. Variation of the OPC belt potential.
  - a. The OPC belt is biased to  $-CBV(V)$ .
  - b. The OPC belt surface is evenly charged to  $-Vo(V)$  in the charging process.
  - c. During the exposing process, the optical unit emits a laser beam that strikes the OPC belt surface forming an electrostatic image. The electrostatic image is at  $-VR(V)$  potential.
  - d. The negatively charged toner is moved to the OPC belt in the development process due to the difference between  $-VR(V)$  and  $-DBV(V)$ . A visible image is the result.
  - e. The negatively charged toner on the OPC belt is moved to the transfer drum because the potential GND of the transfer drum is greater than  $-VR(V)$  of the OPC belt.
  - f. The OPC belt is discharged by the erase lamp radiating on the OPC belt.

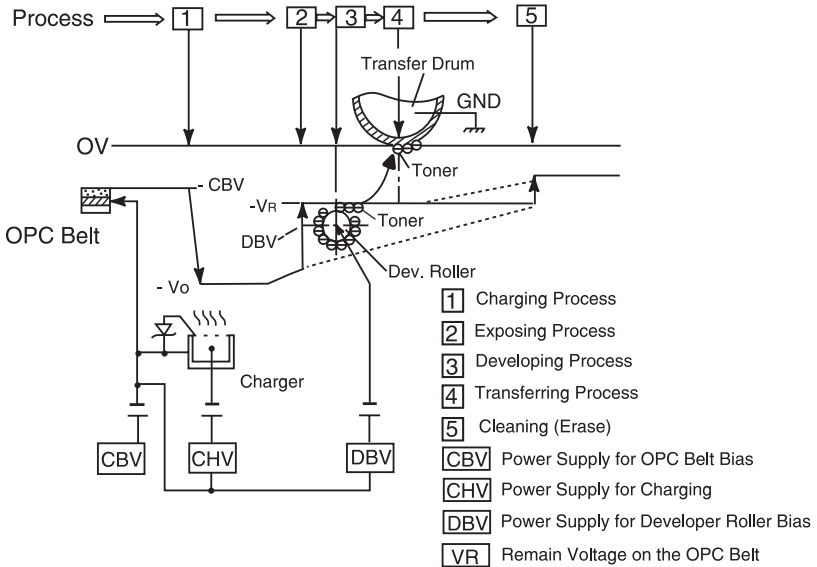



---

## Details of the Print System

### Charging Process

In the charging process, the OPC belt is evenly charged by the charger. See **“Printer Theory of Operation” on page 1-14** for charger unit location.

The charger unit consists of a case, corona wire, and grid.

1. The charger charges the OPC belt surface to the potential  $-V_0(V)$  with the corona charge.

The charger unit controls the grid to a constant voltage of  $ZD(V)$  for even charging.

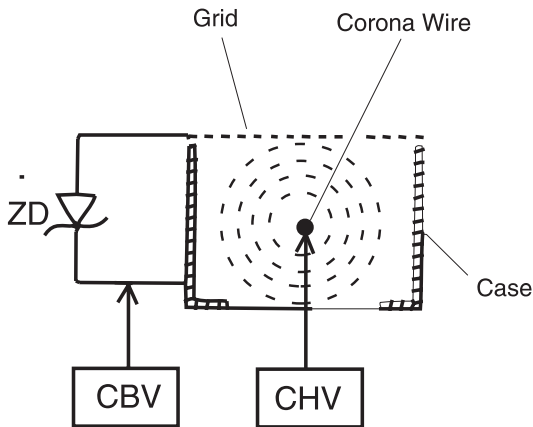

2. Before charging, the OPC belt surface is  $-CBV(V)$ .

The charger unit evenly charges the OPC belt surface to  $-Vo(V)$  by generating a negative charge.

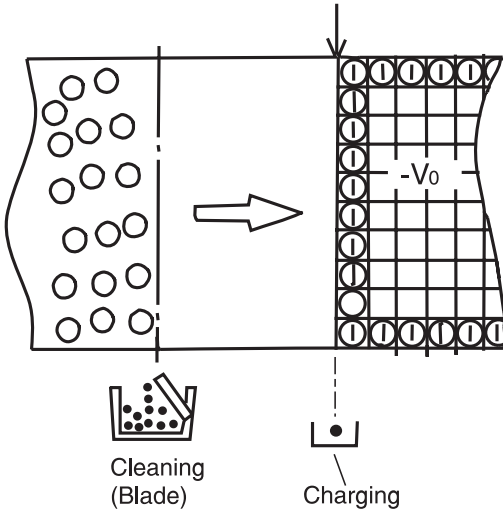

## Exposing Process

In the exposing process, the OPC belt surface is exposed to the laser light which forms an electrostatic latent image.

The luminous source of the laser is a semiconductor laser. See **“Printer Theory of Operation” on page 1-14** for optical unit location.

The laser light scans the OPC belt, forming an electrostatic latent image.

1. The OPC belt surface is charged to the potential  $-V_o(V)$ .
  - a. The laser scans the OPC belt in a rectangular pattern during forward movement of the OPC belt.
  - b. High speed switching of the laser matches the transmitted image data.
  - c. The charge of the areas radiated by the laser light is discharged, creating a  $-V_R(V)$  potential.
  - d. An electrostatic latent image is formed (invisible) on the OPC belt.

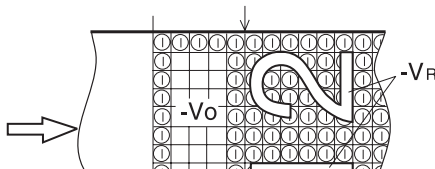

## Developing Process

In the developing process, an electrostatic latent image becomes visible on the OPC belt using the printer toner.

There are four toner cartridges in the 5024 printer. See **“Printer Theory of Operation” on page 1-14** for toner cartridges location. The toner cartridges are located in the printer from top to bottom in the color order of black, yellow, magenta and cyan.

1. Toner adheres to the developer roller.

The developer roller makes contact with the surface of the OPC belt which begins the developing process.

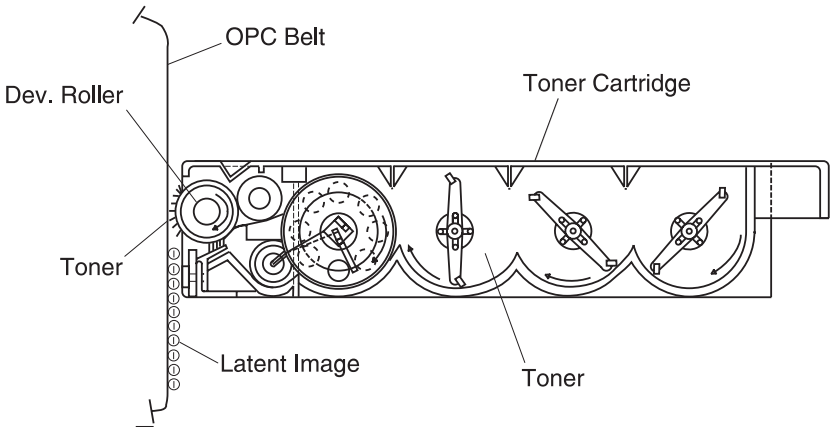

2. The developer roller has been biased to the potential -DBV(V).

The first illustration shows the relationship between the toner, the  $-V_o(V)$  at the non-exposed area of the OPC belt and the  $-V_R(V)$  at the exposed area of the OPC belt.

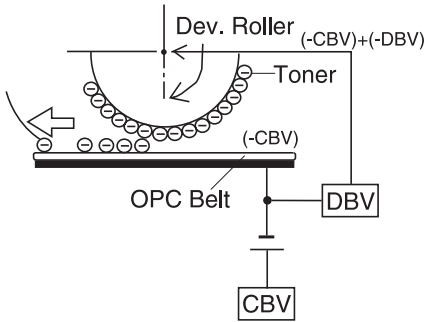

3. Developing is processed by toner adhering to the OPC belt due to the attraction between the toner and the  $-V_R(V)$  at the exposed area of OPC belt.

The toner image becomes visible on the OPC belt.

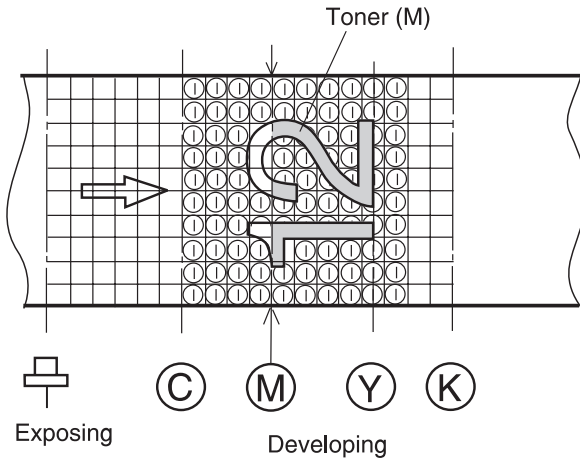

**Note:** No developing takes place on the non-exposed area because the potential of toner and that of the OPC belt is an identical pole and therefore, repels.

## First Transfer (Drum) Process

The first transfer process consists of toner images on the OPC belt being transferred to the transfer drum. See **“Printer Theory of Operation” on page 1-14** for transfer drum location.

**Note:** Semiconductor rubber is attached to the drum surface.

1. After the development process, the OPC belt rotates making direct contact and synchronizing with the aluminum transfer drum.

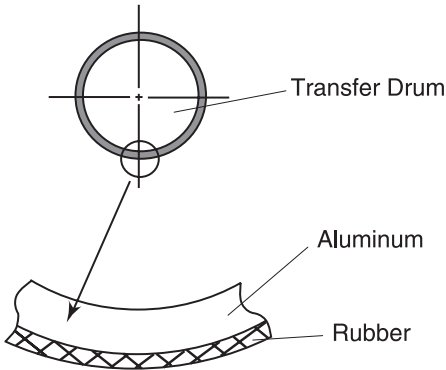

2. The OPC belt has been biased to the potential of  $-CBV(V)$ .  
The potential of the transfer drum is nearly GND.

3. Toner on the OPC belt is moved to the transfer drum

This is due to the difference of potential between the OPC belt and the transfer drum.

Toner that has been developed, in each color, is moved from the OPC belt to the transfer drum, and the two color toner image is overlapped on the transfer drum.

4. The toner image is then transferred to paper.

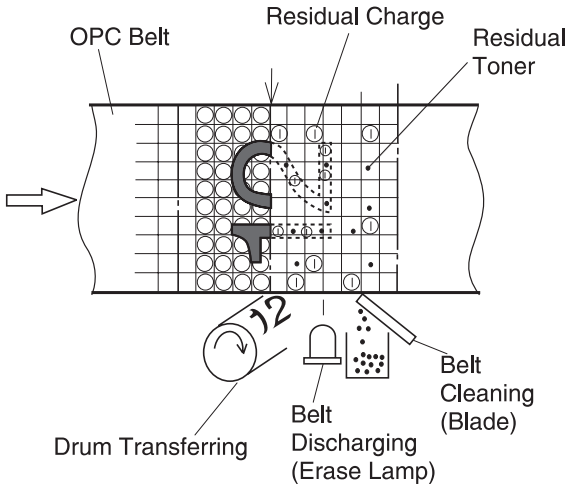

## Belt Discharge (Erase Lamp) Process

In the belt discharge process, an LED light radiating on the OPC belt discharges the residual charge  $-VR(V)$  preparing it for electrical belt cleaning.

The erase lamp is a luminous source of 24 pieces of light emitting diodes (LED).

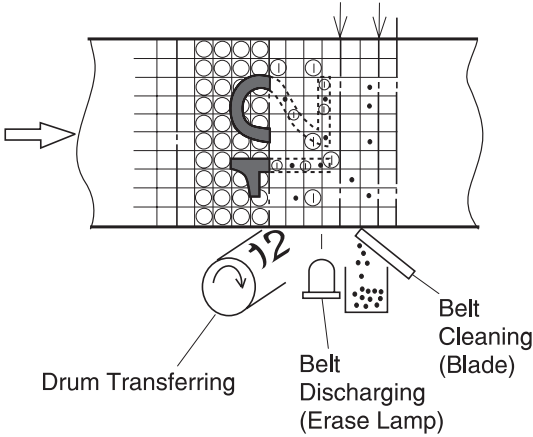



## Belt Cleaning Process

In the belt cleaning process, left behind residual toner adhering to the OPC belt surface is mechanically removed by a blade edge.

The removed residual toner is collected in a waste toner container located by the waste toner feeder.

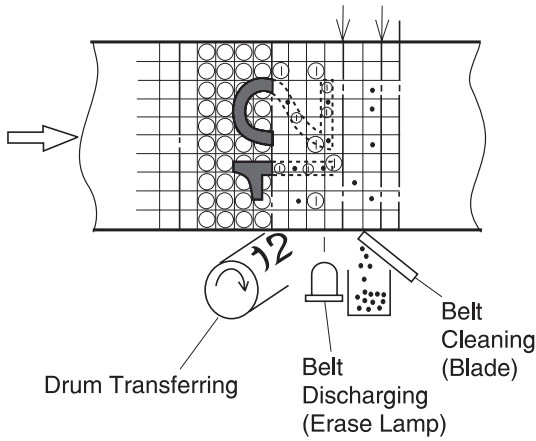

## Details of the Transfer System

### Second Transfer (Paper) Process

In the second transfer process, the toner image on the transfer drum is transferred to paper. See **“Printer Theory of Operation”** on **page 1-14** for second transfer roller location.

The transfer roller, normally separated from the transfer drum, is positively biased by the power supply THV. The transfer roller contacts the transfer drum as paper passes between the transfer roller and the transfer drum. The positive bias of the transfer roller causes the toner to release from the transfer drum and adhere to the paper.

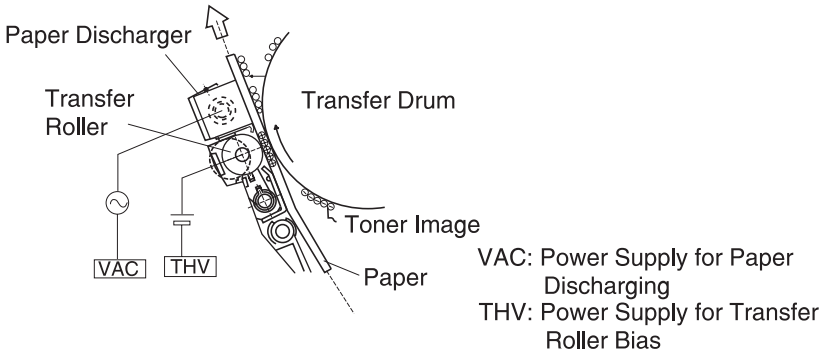

## Paper Discharging Process

In the paper discharging process, the paper, with the image transferred, is separated from the transfer drum by applying an AC charge to the paper. See **“Printer Theory of Operation” on page 1-14** for paper discharge location.

The AC charger unit, consisting of a case and charger wire, has high alternating voltage (VAC) injected into it.

During the transfer process, paper adheres to the transfer drum. The paper is then neutralized (discharged) by injecting the alternating voltage generated by the discharger. Paper is then separated from the transfer drum and moves into the fusing process.

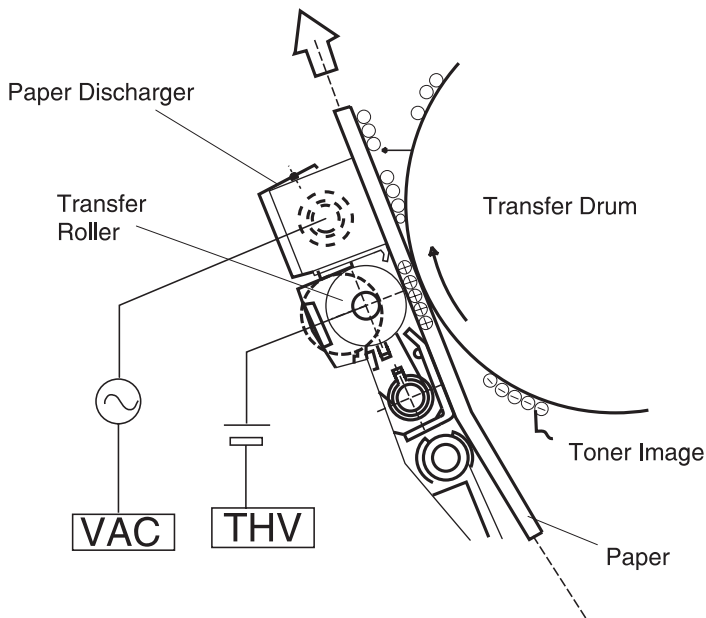

## Drum Cleaner Process

In the drum cleaner process, the residual toner on the surface of the transfer drum is removed after the paper transfer process. See **“Printer Theory of Operation” on page 1-14** for drum cleaner unit location.

The drum cleaner brush is a semiconductor type fur brush (positively self-biased by positive voltage FCBV(V)) which cleans the surface of the rotating transfer drum.

### Notes:

- The cleaning brush is not in contact with the drum while imaging.
- The cleaning brush does contact the drum to remove remaining image from the drum.

The rotating drum cleaning roller is biased to the positive FCBV(V), causing the negatively charged residual toner to be electrically absorbed into the drum cleaner brush. The residual toner is attracted by the positive FCBV(V) and adheres to the surface of the drum cleaner roller.

Waste toner, adhering to the surface of the drum cleaner roller, is removed by the cleaning blade and collected into the waste toner container located by the waste toner feeder.

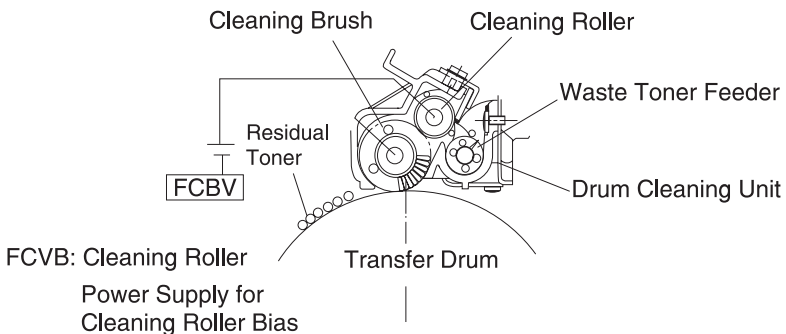

## Details of the Optical System

In the optical system process, the printer utilizes a semiconductor laser diode as a light source. This laser diode is controlled by fast switching which matches the transmitted image data (video signal).

The generated laser light scans the OPC belt through a polygon mirror and lens. The electrostatic latent images are formed on the OPC belt.

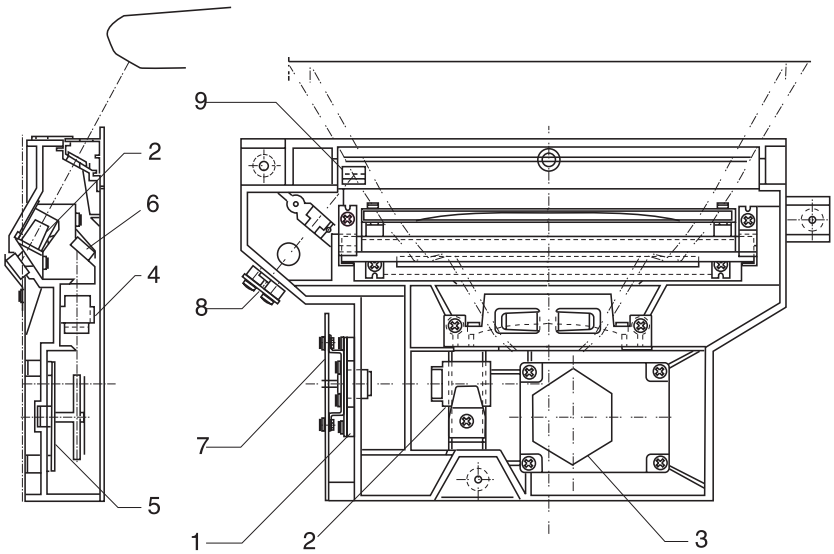

The Optical printhead unit consists of following parts:

No.	Description
1	Laser unit: laser diode light emitting source
2	Cylinder lens: laser beam condenser
3	Polygon mirror: hexahedral mirror that reflects the laser beam
4	F-lens: laser beam focus lens
5	Scanner motor: rotates the polygon mirror

**5024-001**

<b>No.</b>	<b>Description</b>
6	Mirror: laser beam path reflecting mirror
7	LDC: laser diode control circuit
8	PD: photo detector
9	BTD mirror: beam timing detector mirror to guide the laser beam to PD

## Details of the Paper Transportation System

In the paper transportation process, paper is automatically fed by the pick-up roller and transported to the registration roller. The registration roller synchronizes with the transfer drum. The registration roller transports the paper to the transfer roller. During the transfer process, the transfer roller forwards the paper to the fuser rollers. During the fusing process, the fuser rollers transport the fused paper to the exit roller and the exit roller pushes the final paper out of the paper exit unit.

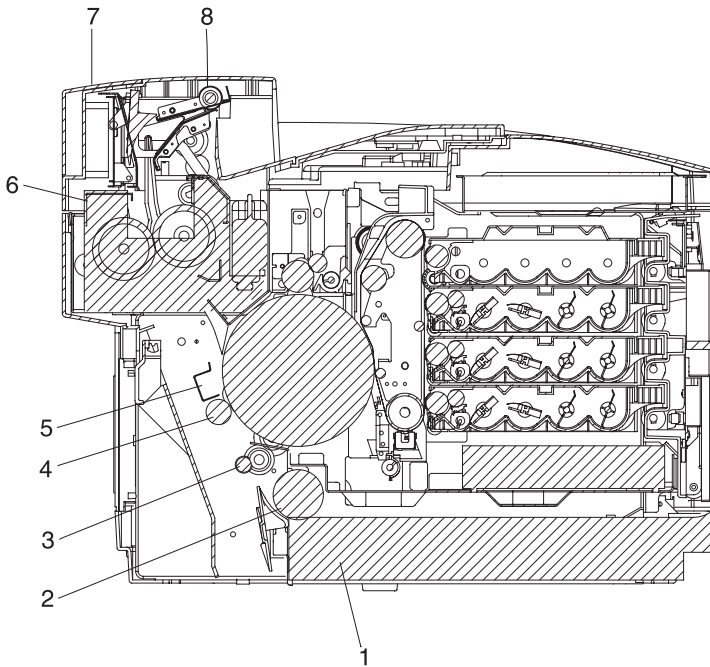

Paper Transportation system consists of following parts:

No.	Name of Part	Outline of Function
1	Paper Cassette	Drawer to accommodate paper to be automatically fed through the printer.
2	Pick-Up Roller	Roller to feed paper one by one, preventing multi-feed.

<b>No.</b>	<b>Name of Part</b>	<b>Outline of Function</b>
3	Registration Roller	Roller to transport paper synchronizing with the transfer drum.
4	Transfer	Print processing utilizing the transfer drum and transfer roller to transfer a toner image to paper.
5	Paper Discharging	Corona generator to generate AC corona for separating paper from the transfer drum.
6	Fuser Unit	Mechanical part that utilizes a heat roller to fuse the toner image to the paper
7	Paper Exit Unit	Mechanical part used to exit the fused paper from the printer.
8	Paper Exit Roller	Roller used to exit the fused paper from the printer.



## Fusing Unit

The fusing unit utilizes a thermal fusing system that contains two rollers with an inner heating element. Paper carrying a toner image passes between the heat rollers. Heat and pressure are applied to the paper.

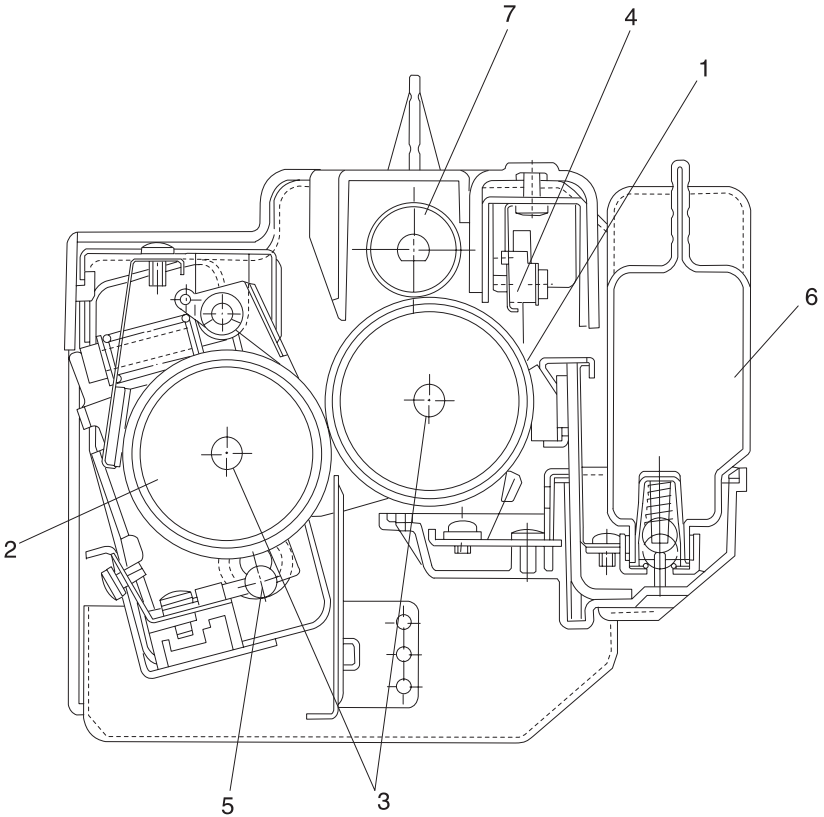

The fusing unit consists of the following components:

No.	Name of Part	Outline of Function
1	Fusing roller	Roller used for fusing, containing a heater.
2	Back-Up roller	Pressure roller containing a heater.

**5024-001**

<b>No.</b>	<b>Name of Part</b>	<b>Outline of Function</b>
3	Fusing heater	A heating device that is heated by a halogen lamp.
4	Thermistor	A sensor that detects the temperature of the fuser roller's surface.
5	Thermal fuse	Protective device that prevents the fuser roller from being excessively heated.
6	Oil bottle	Container that holds the silicone oil for fusing.
7	Cleaning roller	Roller that cleans the fuser roller.

## Fusing Process

1. Silicone oil, supplied from the oil bottle, is applied to the fuser roller surface and the back-up roller.
2. The toner image is transferred on the paper, but not yet fused to the paper.
3. The transported paper (toner transferred on, but not fused to the paper) passes between the heater roller and the back-up roller.

Each roller is heated to approximately 150°C and receives approximately 156N, from the opposite heat roller.

4. When the paper carrying the toner image passes between the two heated rollers, the toner melts and is fused to the paper.
5. The fused paper is separated from the heater rollers and ejected from the printer.

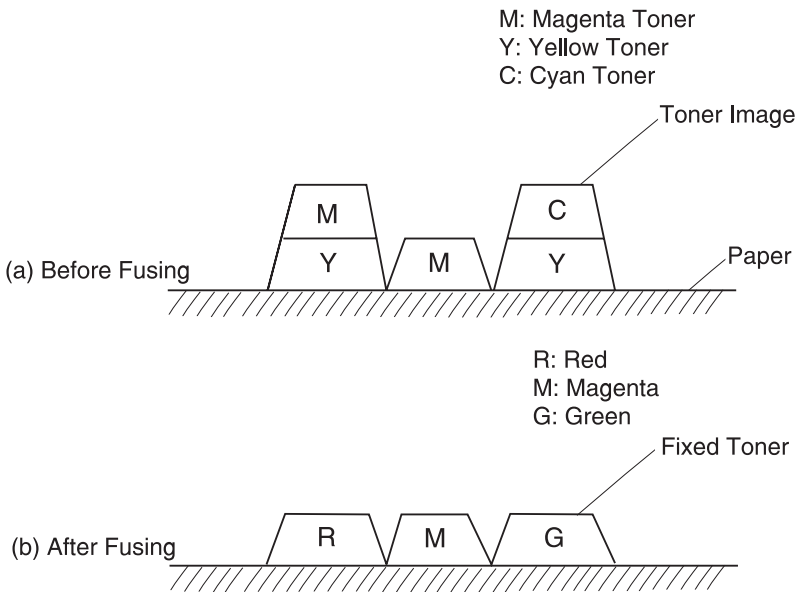

## Control System Structure

### Electrical System and Function

The main engine (MCTL P.W.B.) board controls most of the main electrical parts in this printer.

No.	Control Process	Outline of Function
1	Print process control	Controls the print process from paper feed through paper exit.
2	Laser output control	Automatically controls the laser output to the default.
3	Fuser temperature control	Controls the fuser heater so the fuser roller and the back-up roller reach the temperature.
4	Toner sensing control	Controls the sensing procedures of toner empty status.
5	Interface control (video signal)	Processes the input and output signal with the external controller computer.
6	Operator panel indicator	Displays the printer operation status in the operator panel indicator.
7	Error control	Controls the safe stop procedures when errors occur in the printer.
8	Receiving signal from engine	Operator selection.

## Control of Print Process

### Control Block Diagram

No.	Control Process	Outline of Function
1	Sequence control	Controls the print sequence of the printer.
2	Temperature control	Controls the temperature of the fuser unit.
3	Toner empty sensing control	Controls the toner empty status for each toner cartridge.
4	Operator panel control	Controls the operator panel indication and the operator signals.
5	Error processing control	Senses the errors occurring in the printer as well as the stop procedures.
6	Interface control	Controls the receipt and transmission of the interface signals from the external controller.
7	Laser control	Controls the laser scanning and laser power.

**Note:** A micro CPU mounted on the main engine (MCTL P.W.B.) controls the print processes.

# Print Sequence Diagram

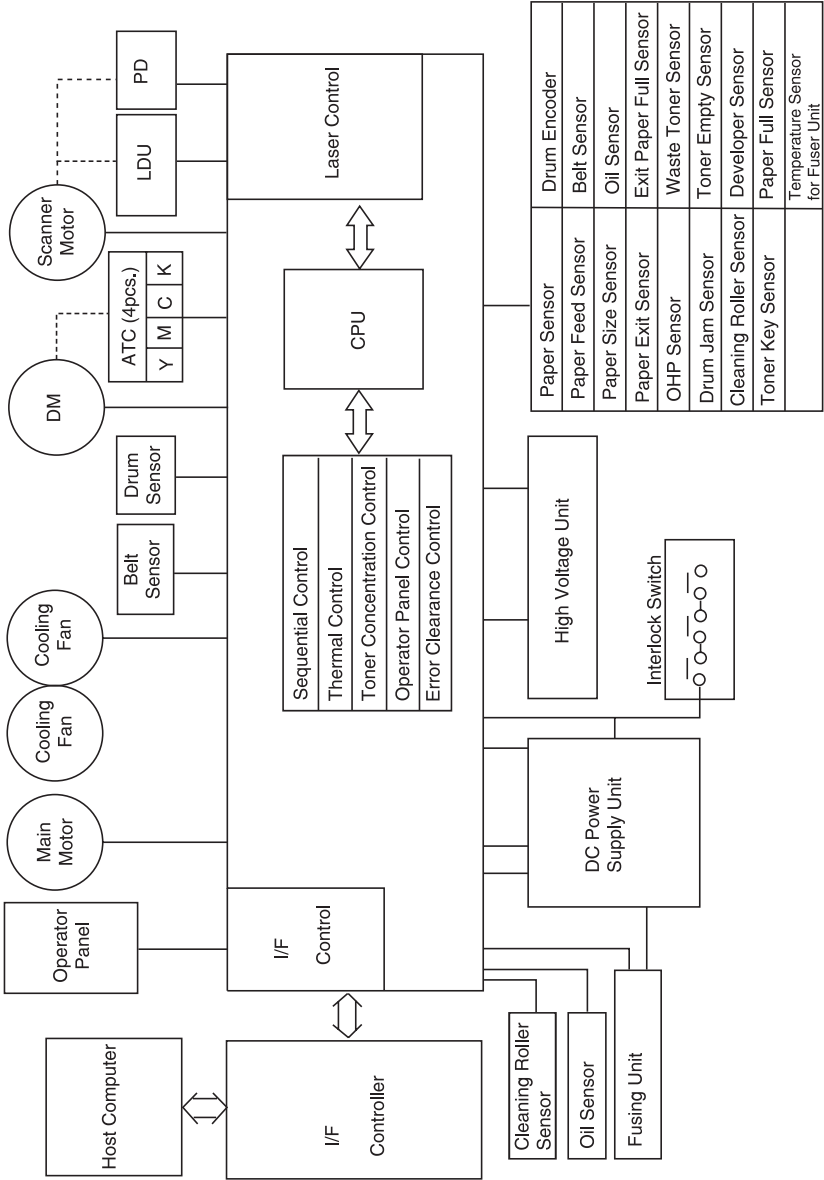

## Laser Drive Control Circuit

The laser drive control circuit (LDC) consists of a video signal input circuit, laser drive circuit, laser diode, output sensing circuits and output control circuit. See the illustration.

1. When the video signal is received, the laser drive control circuit switches the laser diode switch on and radiates according to the video signal.
2. The radiated laser beam, senses the photo detector (PD). The detected signal is returned to the output control circuit.
3. The output control circuit controls the radiated output to a constant, by comparing the laser output default with the feedback value transmitted from the output sensing circuit.
4. The laser beam, scanned by the scanner motor, is sensed by the beam detector (PD), and then outputs the beam detecting timing (BDT) signal.





## Interface Control

### Interface Type

The printer controller acts in conjunction to the LPC. Through the video interface, the LPC controls the printer and operator panel using command/status communication and transmits the synchronized video data to the printer laser diode. The operator panel is physically resident on the engine.

### Interface Connection

The interface connector of the laser printer DL3 is connected to the host system as shown in the following illustration.

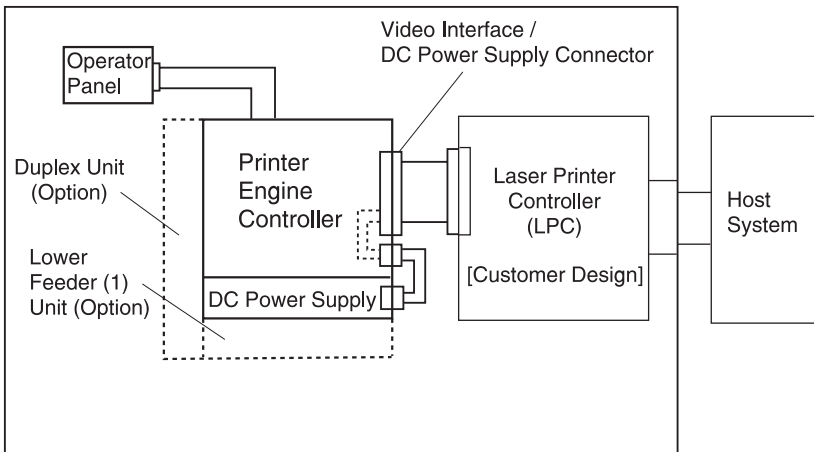

## Lower Feed Unit Theory of Operation

The lower feed unit is used for two purposes:

1. Provide paper to the printer
2. Provide paper, from the duplex unit, to re-enter the print cycle

The lower feed unit has a paper size detection mechanism which has a size lever in Tray 2 and a size sensor (PSL) in the lower feed unit. It also has an empty paper actuator and sensor (PEL).

The paper is picked by the paper pick-up clutch (PKCL) transferring motion from the printer to the pick-up roll. The paper is then fed to the printer registration roll. The lower feed unit is also used to transport paper from the duplex unit back to the printers registration roll for two side printing. The lower feed clutch drive (DPKCL) is activated during duplex printing only.

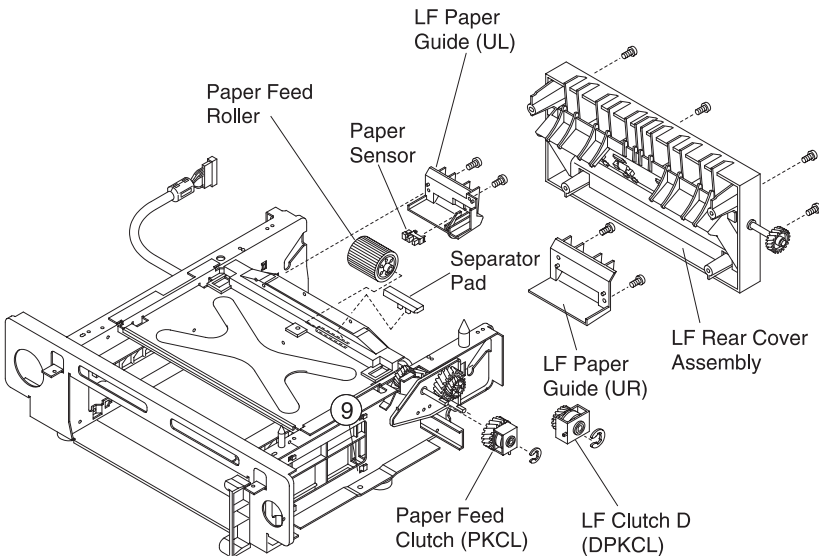

---

## Duplex Theory of Operation

The duplex unit allows the printer to print on both sides of a sheet of paper. The duplex unit uses two motors to move the paper from the paper exit of the printer through the duplex unit. The paper is fed back into the printer through the attached lower feed unit.

The duplex sequence of paper movement is as follows:

1. Paper exits the printer through the top instead of the paper exit bin.

This is accomplished by an upper solenoid (DSOL-U) in the duplex unit moving the upper shutter assembly directing paper into the duplex unit.

2. The upper duplex transport motor 2 (DPM2) and rollers feed the paper into the duplex unit.
3. The paper is stopped, by the duplex registration roller, for staging.

The paper passes over a paper sensor (PT5) which indicates a paper present signal.

4. The lower duplex motor 1 (DPM1) is energized and the paper is directed from the duplex registration roller through the lower shutter switching the direction of the paper to the paper reverse and transport unit.
5. The lower shutter direction is changed by the lower duplex solenoid (DSOL) allowing the paper to be driven by the duplex motor 1 (DPM1) into the lower feed unit transport rollers.
6. The paper passes over another paper sensor (PT4) for a paper present signal.
7. The lower feed unit transport rollers are driven by the lower feed transport clutch (DPKCL) and delivers the paper to the printers registration roller.
8. The paper is then printed on and passed out of the printer through the top output bin.

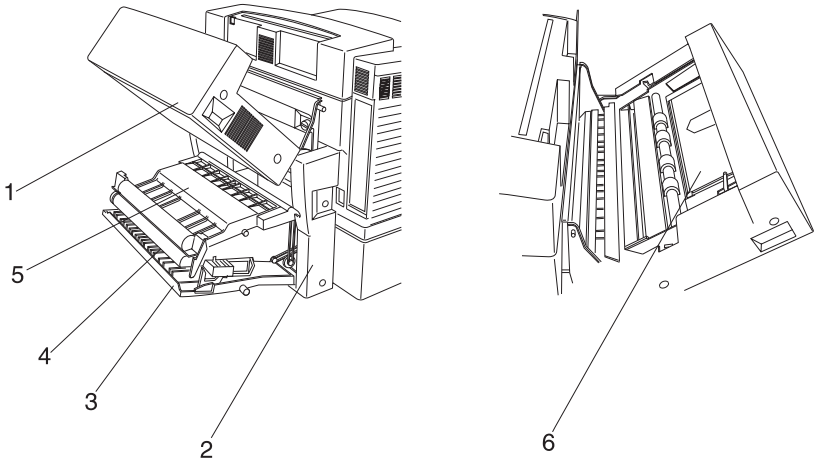

No.	Name of Part	Outline of function
1	D-Top Unit	Transports the front printed page to the duplex unit.
2	D-Lower Unit	Reverses the front printed page for printing on the back of the page.
3	Cover Low (B)	Rear enclosure can be opened to clear an inner paper jam or for performing a maintenance job.
4	Paper Guide RVS Unit	Paper reverse and transport unit can be opened to clear an inner paper jam or for performing a maintenance job.
5	Paper Guide RVS IN	Paper reverse and transport unit can be opened to clear an inner paper jam or for performing a maintenance job.
6	Paper Guide UF	Paper transportation guide in D-top unit can be opened when DUP MEDIA JAM message is displayed.

---

## 2. Diagnostic Information

---

### Start

**CAUTION:** Remove power from the printer before you connect or disconnect any cable, electronic board or assembly, for personal safety and to prevent damage to the printer. Always use the hand grips on the side of the printer and be sure your fingers are not under the printer when you set the printer down.

Use the service error codes, user status messages, user error messages, symptom tables, service checks, and diagnostic aids, to determine the corrective action necessary to repair a malfunctioning printer.

Service error codes are indicated by a three-digit error code. If a service error code displays, go to the **“Service Error Codes” on page 2-2**.

User status messages provide the user with information on the current status of the printer. “Ready” displays on the first line of the display unless Power Saver is invoked, then Power Saver is displayed. If a user status message displays, go to the **“Operator Messages” on page 2-9**.

User error messages are indicated by a two or three digit error code which provides the user with information explaining a problem with a print cartridge, paper jam, option, port, and so on. If a user error message displays, go to the **“Operator Messages” on page 2-9**.

The User Messages section sometimes allows a servicer to isolate printer problems. This section also gives actions to be taken when they do not set or clear.

If you have a failing symptom, go to the **“Symptom Tables” on page 2-32**. Locate your symptom and take the appropriate action.

If a service error code appears while you are working on the printer, go to the **“Service Error Codes” on page 2-2** and take the appropriate action.

## Service Error Codes

Error Code	Action
900 RIP Software	Contact customer service center, or Lexmark support center
901 Yellow Developer Clutch Error (DCLY)	This error indicates a yellow developer problem. Go to <b>“901—Yellow Developer Clutch Service Check” on page 2-38.</b>
902 Magenta Developer Clutch Error (DCLM)	This error indicates a magenta developer problem. Go to <b>“902—Magenta Developer Clutch Service Check” on page 2-39.</b>
903 Cyan Developer Clutch Error (DCLC)	This error indicates a cyan developer problem. Go to <b>“903—Cyan Developer Clutch Service Check” on page 2-40.</b>
904 Black Developer Clutch Error (DCLK)	This error indicates a black developer problem. Go to <b>“904—Black Developer Clutch Service Check” on page 2-41.</b>
905 YK Developer Solenoid Error (YK PSL)	This error indicates the yellow/black developer switching has a problem. Go to <b>“905—Yellow/Black Developer Solenoid Service Check” on page 2-42.</b>
906 MC Solenoid Error (MC PSL)	This error indicates the magenta/cyan developer switching has a problem. Go to <b>“906—Magenta/Cyan Developer Solenoid Service Check” on page 2-43.</b>
907 Toner Empty Sensor Error (TPD, TTR)	This error indicates the toner empty sensor has a problem. Go to <b>“907—Toner Empty Sensor P.W.B. Board Service Check” on page 2-44.</b>

**5024-001**

<b>Error Code</b>	<b>Action</b>
910 Developing Motor Error (DM)	This error indicates that the developing motor (DM) drive may have a problem.  Go to <b>“910—Developer Motor (DM) Drive Service Check” on page 2-45.</b>
911 Main Motor (MM) Error	This error indicates a problem with the main motor.  Go to <b>“911—Main Motor (MM) Service Check” on page 2-47.</b>
915 Control Fan (CTFAN) Error	This error indicates a problem with the control fan (CTFAN).  Go to <b>“915—Control Cooling Fan Service Check” on page 2-50.</b>
916 Ozone Fan (OZFAN) Error	This error indicates a problem with the ozone fan (OZFAN).  Go to <b>“916—Ozone Fan Service Check” on page 2-51.</b>
917 Fuser Heater Fan (HTFAN) Error	This error indicates a problem with the fuser heater fan (HTFAN).  Go to <b>“917—Fuser Heater Fan Service Check” on page 2-52.</b>
918 Erase LED Error	This error indicates a problem with the erase lamp.  Go to the <b>“918—Erase Lamp Service Check” on page 2-53.</b>
920/922/923 Fuser Temperature Error	These errors indicate a fuser temperature error.  Go to the <b>“920, 922, 923—Fuser Unit Service Check” on page 2-54.</b>
921 Fuser Thermistor Error	This error indicates a problem with the fuser thermistor.  Go to the <b>“921—Fuser Thermistor Service Check” on page 2-55.</b>

**5024-001**

<b>Error Code</b>	<b>Action</b>
92X Fuser Exhausted	<p>The fuser is in a maintenance state and needs to be replaced before any other action can be taken.</p> <p>Have the customer order a new fuser maintenance kit.</p> <p>Replace the fuser and note whether any error code exists.</p>
930/933 Printhead Error	<p>Ensure the printhead connector, LCN1, is properly connected to LCN on the main engine (MCTL P.W.B.) board.</p> <p>If the problem still exists, replace the optical printhead unit.</p> <p>If this does not correct the problem, replace the main engine (MCTL P.W.B.) board.</p>
934 Printhead Power Error	<p>Ensure the printhead connector, LCN1, is properly connected to LCN on the main engine (MCTL P.W.B.) board.</p> <p>If the problem still exists, replace the low voltage power supply (LVPS).</p>
939 RIP to Engine Communication Error	<p>Indicates that the RIP controller board and the main engine (MCTL P.W.B.) board cannot communicate. The RIP board, main engine (MCTL P.W.B.) board or cabling may be defective. Check each board for correct installation and be sure all grounds are secure. If no problem exists, replace the following FRUs in the order shown:</p> <ul style="list-style-type: none"><li>• Main engine (MCTL P.W.B.) board</li><li>• RIP controller board</li></ul>
943 RIP Code and Fonts Error	<p>Indicates that the font ROM and RIP codes are incompatible.</p> <p>Ensure the code is correct.</p>
945/946 Main Engine (MCTL P.W.B.) Board	<p>Turn the power Off and then back On.</p> <p>If the error still exists, replace the main engine (MCTL P.W.B.) board.</p>



**5024-001**

<b>Error Code</b>	<b>Action</b>
947 Process Timing Clock Error	Go to the <b>“911—Main Motor (MM) Service Check” on page 2-47</b> , for more information.
953 NVRAM Chip Failure	Indicates the NVRAM failed the CRC check. Replace the main engine (MCTL P.W.B.) board.
954 NVRAM CRC Failure	Indicates the main engine (MCTL P.W.B.) board NVRAM failed the CRC check. Replace the main engine (MCTL P.W.B.) board.
955 Code CRC Error	Indicates that the code ROM failed the CRC check. Replace the code overlay SIMM.
955 Font ROM Failure	Indicates that the font ROM failed the CRC check. Replace the overlay SIMM.
956 RIP Processor Failure	Indicates that there was a microprocessor failure on the RIP controller board. Replace the RIP controller board assembly.
957 RIP ASIC Failure	Indicates that there was an ASIC failure on the RIP controller board. Replace the RIP controller board assembly.
958 ASIC - Engine Failure	Indicates that there was an ASIC failure on the RIP controller board. Replace the RIP controller board assembly.
959 SRAM Failure	Indicates that there was an SRAM failure on the RIP controller board. Replace the RIP controller board assembly.
960 Memory RAM (soldered) Error	Replace the RIP controller board.
961 Memory RAM Error	Indicates that the DRAM installed in slot 1 on the controller board is defective. Replace the DRAM SIMM. If this does not fix the problem, replace the RIP controller board assembly.

Error Code	Action
962 Memory RAM Error	Indicates that the DRAM installed in slot 2 on the controller board is defective. Replace the DRAM SIMM. If this does not fix the problem, replace the RIP controller board assembly.
963 Memory RAM Error	Indicates that the DRAM installed in slot 3 on the controller board is defective. Replace the DRAM SIMM. If this does not fix the problem, replace the RIP controller board assembly.
964 Download Emulation CRC Error	Indicates that the download emulation CRC has failed. A checksum failure was detected in the emulation header or emulation file. Replace the code overlay SIMM.
965 Download Emulation Outdated Error	<p>Indicates that the download emulation is outdated. Time stamps indicate that the download emulation and controller code are incompatible.</p> <ul style="list-style-type: none"> <li>• Disable the download emulation.</li> <li>• Program the download emulation into the code overlay SIMM.</li> <li>• If the above steps do not fix the problem, replace the code overlay SIMM and re-download the emulation.</li> </ul>
970 through 974	Reserved
975 Unrecognizable Network Card x Error	Indicates that a failure has occurred with the network card installed in slot x (x = 1, 2 or 3).
976 Unrecoverable Software in Network Card x Error	Indicates an unrecognizable network card x. Replace network card x.
977	Removed
978 Bad Checksum While Programming Network Card x Error	Indicates that a bad checksum has been detected while programming network card x. Replace network card x.

Error Code	Action
979  Flash Parts Failed While Programming Network Card x Error	Indicates that flash parts failed while programming network card x. If this is a network model printer, replace the controller board.
980  Duplex Controller Hardware Error	The error indicates a problem with the duplex (DUP P.W.B.) and main engine (MCTL P.W.B.) hardware control.  Reset the printer power switch.  Ensure the harness between the DUP P.W.B. board and the main engine (MCTL P.W.B.) board are connected.  If the problem still exists, replace the duplex (DUP P.W.B.) board.
981  Duplex Motor (DPM1, DPM2) Error	The error indicates a problem with the duplex motors, DPM1, and DPM2.  Go to <b>“981—Duplex Motor (DPM1, DPM2) Service Check” on page 2-56.</b>
982  Upper Solenoid (DSOL-U) Error	This error indicates a problem with the duplex upper solenoid (DSOL-U).  Go to <b>“982—Duplex Upper Solenoid (DSOL-U) Service Check” on page 2-58.</b>
983  Duplex Fan (D-FAN) Error	This error indicates a problem with the duplex fan (D-FAN).  Go to <b>“983— Duplex Fan (D-FAN) Service Check” on page 2-59.</b>
984  Duplex Lower Solenoid (DSOL-L) Error	This error indicates a problem with the lower duplex solenoid (DSOL-L).  Go to <b>“984—Duplex Lower Solenoid (DSOL-L) Service Check” on page 2-60.</b>
990  Drum Encoder Sensor (HPSEN) Error	This error indicates a problem with the transfer drum sensor (HPSEN).  Go to <b>“990—Transfer Drum Encoder Sensor (HPSEN) Service Check” on page 2-61.</b>

Error Code	Action
991  Transfer Roller Cam Clutch (TRCM) Error	This error indicates a problem with the transfer Roller cam clutch.  Go to <b>“991—Transfer Roller Cam Clutch (TRCM) Service Check” on page 2-63.</b>
992  Drum Cleaner Brush Cam Clutch (FBCM) Error	This error indicates a problem with the drum cleaner brush cam clutch.  Go to <b>“992—Drum Cleaner Brush Cam Clutch (FBCM) Service Check” on page 2-64.</b>
993  Cleaner Clutch (FBCL) Error	This error indicates a problem with the cleaner clutch (FBCL).  Go to <b>“993—Cleaner Clutch (FBCL) Service Check” on page 2-65.</b>
994  Fuser Unit Clutch (FUCL) Error	This error indicates a problem with the fuser clutch (FUCL).  Go to <b>“994—Fuser Clutch (FUCL) Service Check” on page 2-66.</b>
995  OPC Belt Cartridge Belt Marker Sensor (PBS) Error	This error indicates a problem with the OPC belt cartridge belt marker sensor (PBS).  Go to <b>“995—OPC Belt Cartridge, Belt Marker Sensor (PBS) Service Check” on page 2-67.</b>
997  Charger HV Unit (HVU) Error	This error indicates a problem with the high voltage power supply unit (HVU).  Go to <b>“997—High Voltage Power Supply Unit (HVU) Service Check” on page 2-69.</b>

## Operator Messages

Message	Description	Action
Bin Full	A bin is full. The bin full warning is cleared when the output level reported by the bin is no longer full.	<p>Check the tray/bin full sensor PFUL and connector DCN14 on IOD1 board.</p> <p>Replace as necessary.</p> <p>Replace the IDO1 P.W.B. board if necessary.</p> <p>Replace the printer main engine (MCTL P.W.B.) board, if necessary.</p>
Close Top Cover	The top cover is open.	<p>Close the top cover. Check top cover top cover open switch (DSW2), cable and connector DCN5 on the IDO1 P.W.B. board. Replace if necessary.</p> <p>Replace the IDO1 P.W.B. board if necessary.</p> <p>Replace the main engine (MCTL P.W.B.) board, if necessary.</p>
Close Duplex Door	The duplex door is open.	<p>Check the duplex interlock switches SW1, SW2, SW3, SW4, cable and connectors DPCN4 on the duplex (DUP P.W.B.) board. Replace as necessary.</p> <p>Replace printer main engine (MCTL P.W.B.) board, if necessary.</p>

Message	Description	Action
Close Front Door	The front door is open.	<p>Close front door. Check switch (DSW1), cable and connector DCN5 on the IDO1 P.W.B. board. Replace if necessary.</p> <p>Replace the IDO1 P.W.B. board if necessary.</p> <p>Replace printer main engine (MCTL P.W.B.) board, if necessary.</p>
Close Rear Door	The rear door is open.	<p>Close rear door. Check switch (DSW3), cable and connector DCN5 on the IDO1 P.W.B. board. Replace if necessary.</p> <p>Replace the IDO1 P.W.B. board if necessary.</p> <p>Replace printer main engine (MCTL P.W.B.) board, if necessary.</p>
Did you replace the Fuser?	The fuser page counter has exceeded the fuser page limit.	<p>Replace fuser kit.</p> <p><b>Note:</b> This is a customer orderable part.</p> <p>This message will only be cleared when the fuser page count has been reset to zero.</p> <p><b>Note:</b> Replace the fuser to prevent this message from recurring.</p> <p>To continue printing:</p> <ul style="list-style-type: none"> <li>• Press <b>Go</b> if you replaced the fuser.</li> <li>• Press <b>Stop</b> if you have not replaced the fuser.</li> </ul>

Message	Description	Action
Did you replace the Fuser Cleaner?	Cleaning roller is near end of life. If the cleaning roller is not replaced when the warning is cleared, the printer repeats this warning each time the top cover is opened or closed.	<p>Replace fuser cleaner roller.</p> <p><b>Note:</b> This is a customer orderable part.</p> <p>Replace the fuser cleaner to prevent this message from recurring.</p> <p>To continue printing:</p> <ul style="list-style-type: none"> <li>• Press <b>Go</b> if you replaced the fuser cleaner.</li> <li>• Press <b>Stop</b> if you have not replaced the fuser cleaner.</li> </ul> <p>Reset maintenance kit counter.</p>
Did you replace the Maintenance Kit?	This message appears when the user opens or closes the top cover (or answers one of the other replacement messages) and the maintenance kit is in the warning state and needs to be replaced.	<p>Replace the maintenance kit to prevent this message from recurring.</p> <p>To continue printing:</p> <ul style="list-style-type: none"> <li>• Press <b>Go</b> if you replaced the maintenance kit.</li> <li>• Press <b>Stop</b> if you have not replaced the maintenance kit.</li> </ul> <p>Reset maintenance kit counter.</p>
Did you replace the Photo Dev Cart? (OPC belt cartridge)	Photo developer is near-life. If the photo developer cartridge is not replaced when the warning is cleared, the printer repeats this warning each time the top door is opened or closed.	<p>Replace photo developer (OPC belt cartridge).</p> <p><b>Note:</b> Replace the photo developer (OPC belt cartridge) to prevent this message from recurring.</p> <p>To continue printing:</p> <ul style="list-style-type: none"> <li>• Press <b>Go</b> if you replaced the photo developer (OPC belt cartridge).</li> <li>• Press <b>Stop</b> if you haven't replaced the photo developer (OPC belt cartridge).</li> </ul>

Message	Description	Action
Menus Disabled	<p>The printer menus have been disabled. This occurs when <b>&lt;Menu&gt;</b> is pressed while the printer is <b>Ready</b> and menu lockout is active.</p> <p>The printer display shows this message for one second and then returns to the <b>Ready</b> message.</p> <p>No button actions are possible while this message is displayed.</p>	<p>If the operator has disabled the menu and you want to run operator print tests, turn the machine Off and then press <b>Go</b> and <b>Stop</b> as you turn the machine on.</p>
Not Ready	<p>The printer is in the not ready state, which means it is not ready to receive or process data.</p> <p>This message displays when <b>Stop</b> is pressed during a print job.</p>	<p>Press <b>Go</b> to take the printer out of the not ready state.</p> <p>Or, reset the printer. Press <b>&lt;Menu&gt;</b> to access the job menu. Select <b>Reset Printer</b>.</p>
Performing Self Test	<p>The printer is running the normal series of start-up tests after it is powered on. When the tests are complete, the printer returns to <b>Ready</b>.</p> <p>No button actions are possible while this message is displayed.</p>	<p>Printer performs self-test.</p>



5024-001

Message	Description	Action
Remove Paper Standard Bin	Remove paper.	<p>Check paper exit full sensor (PFUL), cable and connector DCN14 on the IDO1 P.W.B. board.</p> <p>Replace the IDO1 P.W.B. board if necessary.</p> <p>Replace printer main engine (MCTL P.W.B.) board, if necessary.</p>
Replace Transfer Kit	The transfer page counter has exceeded the transfer page limit.	Replace transfer kit (customer ordered). Reset transfer roller counter.
Supplies	At least one of the printers supplies requires attention. This could be a paper tray low on paper or a photo developer cartridge needs replacing.	<p>Press <b>Menu&gt;</b> or <b>Menu&lt;</b> to open the supplies menu and identify which supply item needs replacing.</p> <p>Replace the appropriate printer supplies. See operator manual for more information.</p>
Tray 1 Missing Tray 2 Missing	An input tray is missing from the printer.	<p>Check the tray, the cassette set sensor, and connectors DCN6 and DCN8.</p> <p>Tray 1–PSU Tray 2–PSL Replace as necessary.</p> <p>Replace the IDO1 P.W.B. board if necessary.</p> <p>Replace the printer main engine (MCTL P.W.B.) board, if necessary.</p>

Message	Description	Action
Tray 1 Empty Tray 2 Empty	An input tray is out of media.	<p>Check the tray, the cassette empty sensor, and connectors DCN8 and DCN4 on the ID01 board.</p> <p>Tray 1–PEU Tray 2–PEL</p> <p>Replace as necessary.</p> <p>Replace the ID01 P.W.B. board if necessary.</p> <p>Replace the printer main engine (MCTL P.W.B.) board, if necessary.</p>
30 Color Toner Missing	The specified cartridge (Cyan, Magenta, Yellow, or Black) is not installed in the printer.	<p>Insert the cartridge and close the cartridge cover to clear the message.</p> <p>Check the toner key sensor (TNK) and connector DCN15 on the ID01 P.W.B. board and replace, if necessary.</p> <p>Replace the ID01 P.W.B. board if necessary.</p> <p>Replace the printer main engine (MCTL P.W.B.) board, if necessary.</p>
34 Wrong Paper Size in Tray x	Install correct paper size.	<p>Check paper size detection sensor and connectors DCN6 and DCN8 on the ID01 P.W.B. board.</p> <p>Tray 1–P.W.B.-S1 (PSU) Tray 2–PSL</p> <p>Replace if necessary.</p> <p>Replace the ID01 P.W.B. board if necessary.</p> <p>Replace the printer main engine (MCTL P.W.B.) board, if necessary.</p>

Message	Description	Action
35 Res Save Off Deficient Memory	The printer lacks the memory needed to enable <b>Resource Save</b> . This message usually indicates that too much memory is allocated for one or more of the printer link buffers.	<p>To enable <b>Resource Save</b> after this message is displayed, either install additional memory or set each link buffer to the <b>Auto</b> value.</p> <p>After you set all link buffers to <b>Auto</b>, exit the printer menus to activate link buffer changes.</p> <p>When <b>Ready</b> is displayed, enable <b>Resource Save</b> in the Setup Menu and modify the link buffers again.</p> <p>Press <b>Go</b> to clear the message. The printer automatically disables <b>Resource Save</b> and continues.</p>
37 Insufficient Collation Area	This message is displayed when the printer memory used to store pages is too full to collate the print job.	<p>Press <b>Go</b> to print the portion of the job already stored and begin collating the rest of the job.</p> <p>Cancel the print job. Press <b>Menu&gt;</b> or <b>&lt;Menu</b>. The Job Menu is displayed. Press <b>Menu&gt;</b> or <b>&lt;Menu</b> until Cancel Job appears on the second line. Press <b>Select</b>.</p>
37 Insufficient Defrag Memory		Refer to operator manual.
37 Insufficient Memory		Refer to operator manual.

Message	Description	Action
38 Memory Full	This message is displayed when the printer memory used to store pages is full.	<p>Press <b>Go</b> to clear the message and continue printing. Some data may not print or may not print correctly.</p> <p>Cancel the print job. Press <b>Menu&gt;</b> or <b>Menu&lt;</b> to open the job menu. When cancel job appears on the second line. Press <b>Select</b>.</p> <p>Reduce the complexity of the job:</p> <ul style="list-style-type: none"> <li>• Reduce the number of graphics or images on a page.</li> <li>• Delete unnecessary downloaded fonts or macros.</li> <li>• Change the Print Quality setting.</li> <li>• Install additional printer memory to avoid future Memory Full errors.</li> </ul>
39 Complex Page	This message is displayed when the page is too complex to print.	<p>Press <b>Go</b> to clear the message and continue printing. Some data may not print or may not print correctly.</p> <p>Cancel the print job. Press <b>Menu&gt;</b> or <b>Menu&lt;</b> to open the job menu. When cancel job appears on the second line. Press <b>Select</b>.</p> <p>To avoid another Complex Page error:</p> <ul style="list-style-type: none"> <li>• Set Page Protect On from the Setup Menu and resend the job.</li> <li>• Reduce the complexity of the page by using fewer fonts, macros, and graphics.</li> <li>• Install additional printer memory.</li> </ul>

Message	Description	Action
50 PPDS Error		Refer to operator manual.
51 Defective Flash	The printer detects a defective flash during power on, or during format and write to flash operations.	<p>Press <b>Go</b> to clear the message. Flash operations are not allowed until the problem is resolved.</p> <p>Remove the defective flash memory card and try another.</p>
52 Flash Full	There is not enough free space in the flash memory card to hold the data that was sent.	<p>Press <b>Go</b> to clear the message and continue processing. Down-loaded fonts and macros not previously stored in flash memory or disk are deleted.</p> <p>Reset the printer. Press <b>Menu&gt;</b> or <b>Menu&lt;</b> to open the job menu. When <b>Reset Printer</b> appears on the second line. Press <b>Select</b>.</p>
53 Unformatted Flash	The printer detected an unformatted flash memory card during the power on process. Flash operations are not allowed until the flash is formatted.	<p>Try the following:</p> <ul style="list-style-type: none"> <li>• Format the flash memory card using <b>Format Flash</b> in the Tests Menu.</li> <li>• Send the data again.</li> <li>• If the error condition remains, the flash memory card is defective and must be replaced.</li> <li>• Press <b>Go</b> to clear the message. The flash memory is ignored and normal operation continues.</li> </ul>
54 Network x Software Error	The printer software has detected that a network port is installed and cannot establish communications with it.	Press <b>Go</b> to clear the message. The printer disables all communications to the associated network interface. No data can be transmitted through this interface. You can program new firmware in the network interface through the parallel port after this message clears.

Message	Description	Action
54 Par x ENA Connection Lost	<p>An external network adapter (ENA) that was once connected to the specified parallel port is no longer responding.</p> <p>The printer only recognizes the missing connection when the printer is first turned On.</p>	<p>Ensure the cable connecting the ENA and the printer is securely attached. Turn the printer Off and then On again to see if the printer recognizes the connection.</p> <p>Press <b>Go</b> to clear the message. The printer erases any reference to the ENA and then resets.</p>
54 Serial Option x Error	<p>A serial interface error has been detected (framing or parity). This error usually indicates the serial link has not been set up correctly.</p> <p><b>x</b> represents optional serial port 1 through 3.</p>	<p>Press and hold <b>Select</b> and then press <b>Return</b> to determine the cause of the host interface error.</p> <p>When the serial error is displayed, the reporting of other serial errors is suppressed until interface parameters are changed or the printer is turned off.</p> <p>Check the interface:</p> <ul style="list-style-type: none"> <li>• Verify that the correct cable is used.</li> <li>• Make sure the serial interface parameters (protocol, baud, parity, data bits) are correct.</li> <li>• Press <b>Go</b> to clear the message and continue printing the job. The print job may not print correctly.</li> <li>• Reset the printer. Press <b>&lt;Menu&gt;</b> to access the job menu. Select <b>Reset Printer</b>.</li> </ul>

Message	Description	Action
54 Serial x Fax Connection Lost	<p>The printer has detected the external modem that was once connected to the serial port is no longer responding.</p> <ul style="list-style-type: none"> <li>• If the printer has been configured to receive faxes from a serial port and the Fax Port setting is not set to disable, it polls the model.</li> <li>• If it detects the modem connection is missing, it displays the attendance message.</li> <li>• If the modem connection is re-established, the printer removes the message from the display.</li> </ul>	<p>If the modem has been intentionally disconnected, you can press <b>Go</b> to clear the message and continue printing.</p>
54 Std Par ENA Connection Lost	<p>An external network adapter (ENA) that was once connected to the standard parallel port is no longer responding. The printer only recognizes the missing connection when the printer is first turned On.</p>	<p>Ensure the cable connecting the ENA and the printer is securely attached. Turn the printer Off and then On again to see if the printer recognizes the connection.</p> <p>Press <b>Go</b> to clear the message. The printer erases any reference to the ENA and then resets.</p>

Message	Description	Action
55 Insufficient Fax Buffer	<p>This attendance message may appear if the printer is processing a print job. The printer must complete the print job before processing the fax data. If the fax buffer is not large enough to hold the fax data, this message is displayed. After this message is posted, the printer breaks the phone connection with the sending fax printer.</p> <p>The ability of the printer to process fax data exceeds the data transmission rate of most fax printers.</p>	<p>Press <b>Go</b> to clear the message and continue processing the current print job.</p> <p>Reset the printer. Press <b>Menu&gt;</b> or <b>Menu&lt;</b> to open the job menu. When reset printer appears on the second line. Press <b>Select</b>.</p>
56 Parallel Port x Disabled	<p>Data was sent to the specified parallel port, but the port has been disabled from the Parallel Buffer menu item.</p>	<p>Press <b>Go</b> to clear the message. The printer discards the data sent to the parallel port.</p> <p>Reset the printer. Press <b>Menu&gt;</b> or <b>Menu&lt;</b> to open the job menu. When reset printer appears on the second line. Press <b>Select</b>.</p>
56 Serial x Port Disabled	<p>Data was sent to the specified serial port, but the port has been disabled from the serial buffer menu item.</p>	<p>Press <b>Go</b> to clear the message. The printer discards the data sent to the serial port.</p> <p>Reset the printer. Press <b>Menu&gt;</b> or <b>Menu&lt;</b> to open the job menu. When reset printer appears on the second line. Press <b>Select</b>.</p>



Message	Description	Action
56 Std Parallel Port Disabled	Data is sent to the printer across the parallel port, but the parallel port is disabled. When the error is displayed, the reporting of other errors is suppressed until the menus are entered or the printer is reset.	<p>Press <b>Go</b> to clear the message. The printer discards the data sent to the parallel port.</p> <p>Reset the printer. Press <b>Menu&gt;</b> or <b>Menu&lt;</b> to open the job menu. When reset printer appears on the second line. Press <b>Select</b>.</p>
58 Too Many Disks Installed	You have more than one hard disk installed.	Turn the printer Off and follow the instructions in your <i>Setup Guide</i> for installing an optional hard disk.
58 Too Many Flash Options Installed	You have more than one flash option installed.	Turn the printer Off and follow the instructions in your <i>Setup Guide</i> for installing and removing flash memory.
61 Defective Disk	The printer detects a defective disk during power on, or during disk format and write operations.	Press <b>Go</b> to clear the message. Hard disk operations are not allowed with a defective hard disk. Remove the defective hard disk and replace it with a new hard disk.
62 Disk Full	There is not enough space available to hold the resources you want to store on disk.	<p>Press <b>Go</b> to clear the message and continue processing. Downloaded fonts and macros not previously stored in flash memory or disk are deleted.</p> <p>Reset the printer. Press <b>Menu&gt;</b> or <b>&lt;Menu</b>. When the Job Menu is displayed press <b>Select</b>. Press <b>Menu&gt;</b> or <b>&lt;Menu</b> until <b>Reset Printer</b> appears on the second line. Press <b>Select</b>.</p>

Message	Description	Action
63 Unformatted Disk	The hard disk installed in your printer has not been formatted. You must format the disk before you can download resources to it.	<p>Press <b>Go</b> to clear the message. If the error message remains, the disk may be defective and need replacing.</p> <p>To format the disk, select format disk from the utilities menu.</p>
70-79 INA errors	These numbered messages are reserved for internal network adapter messages.	Refer to the Drivers, MarkVision and Utilities CD for more information. Also, refer to the documentation that is included with the internal network adapter.
80 Scheduled Maintenance	The printer requires replacement of routine maintenance items to maintain top performance and avoid print quality.	<p>Replace the maintenance kit and reset the printer maintenance counter.</p> <p>Press <b>Go</b> to clear the message and continue printing.</p> <p>Drum cleaner</p> <p>Paper discharge</p> <p>Transfer roller</p>
80 Transfer Roller Missing	The transfer roller is either missing or incorrectly installed.	Correctly install the transfer roller to clear the message.
81 Oil Bottle Empty or Missing	The oil bottle is either empty or missing.	<p>Replace the oil bottle to clear the message and continue printing.</p> <p>Check the sensor (OIL) and connectors DCN6 and DCN1 and replace, if necessary.</p> <p>Replace the IDO1 P.W.B. board if necessary.</p> <p>Replace the printer main engine (MCTL P.W.B.) board, if necessary.</p>

Message	Description	Action
81 Oil Bottle Low	The oil bottle is low on oil.	<p>Replace the oil bottle.</p> <p>Press <b>Go</b> to clear the message and continue printing.</p> <p><b>Note:</b> This is a customer orderable part.</p>
82 Photo Developer (OPC Belt Cartridge) Exhausted	The photo developer (OPC belt cartridge) has reached its end of life.	<p>Replace the photo developer (OPC belt cartridge).</p> <p>Press <b>Go</b> to clear the message and continue printing.</p> <p><b>Note:</b> This is a customer orderable part.</p>
82 Photo Developer (OPC Belt Cartridge) Missing	The photo developer (OPC belt cartridge) is either missing or incorrectly installed.	<p>Correctly install the photo developer (OPC belt cartridge) to clear the message and continue printing.</p> <p>Check the toner key sensor (TNK) and connector DCN15 and replace, if necessary.</p> <p>Replace the IDO1 P.W.B. board, if necessary.</p> <p>Replace the printer main engine (MCTL P.W.B.) board, if necessary.</p> <p>If the printer fails to complete POR, go to <b>“911—Main Motor (MM) Service Check” on page 2-47</b>, for more information.</p>

Message	Description	Action
83 Waste Toner Bottle Full Or Missing	The waste toner bottle is either full or missing.	<p>Install an empty waste toner bottle to clear the message and continue printing.</p> <p>Check the waste toner sensor (TBLE) and connector ECN17 on the P.W.B. board. Replace the waste toner holder assembly, if necessary.</p> <p>Replace the IDO1 P.W.B. board, if necessary.</p> <p>Replace the printer main engine (MCTL P.W.B.) board, if necessary.</p>
83 Waste Toner Bottle Near Full	The waste toner bottle is nearly full.	<p>Empty the waste toner bottle.</p> <p>Press <b>Go</b> to clear the message and continue printing.</p> <p>Check the waste toner sensor (TBLE) and connector ECN17 on the P.W.B. board and replace the waste toner holder assembly, if necessary.</p> <p>Replace the IDO1 P.W.B. board, if necessary.</p> <p>Replace the printer main engine (MCTL P.W.B.) board, if necessary.</p>
84 Transfer Drum Exhausted	The transfer drum has reached its end of life.	<p>Press <b>Go</b> to clear the message.</p> <p>Contact your local Lexmark dealer to arrange for a trained service professional to replace the transfer drum.</p> <p>Reset counter after replacement.</p>

Message	Description	Action
85 Fuser Cleaner Exhausted	The fuser cleaner has reached its end of life.	<p>Replace the fuser cleaner and reset the maintenance counter to continue printing.</p> <p>This is a customer orderable part.</p>
85 Fuser Cleaner Missing	The fuser cleaner is either missing or incorrectly installed.	<p>Correctly install the fuser cleaner to clear the message and continue printing.</p> <p>This is a customer orderable part.</p>
86 Insert Tray 2	Tray 2 is incorrectly installed with the duplex unit in the printer.	<p>Check that the Tray 2 lower feeder is installed correctly and plugged in securely.</p>
87 Fuser Exhausted	The fuser has reached its end of life.	<p>Replace the fuser and the air filter that comes packaged with the fuser.</p> <p>Reset counter after replacement.</p> <p>Press <b>Go</b> to continue printing.</p> <p><b>Note:</b> This is a customer orderable part.</p>
87 Fuser Missing	The fuser is either missing or incorrectly installed.	<p>Check the fuser connector and replace if necessary. Check connector FUCN on the printer main engine (MCTL P.W.B.) board.</p> <p>Correctly install the fuser to clear the message and continue printing.</p> <p>Replace the printer main engine (MCTL P.W.B.) board, if necessary.</p>

Message	Description	Action
88 <color> Toner Empty	The printer has ceased operating because the specified toner cartridge is empty. You cannot print until you replace the specified toner cartridge.	<p>Install a new toner cartridge.</p> <p>Check the toner empty sensors TPD and TTR and connector DCN7 on the IDO1 P.W.B. board. Replace if necessary.</p> <p>Replace the IDO1 P.W.B. board, if necessary.</p> <p>Replace the printer main engine (MCTL P.W.B.) board, if necessary.</p>
88 <color> Toner Low	The printer has detected that the toner supply in the specified cartridge is low. If you do not have the specified toner cartridge, order one now.	<p>Replace the specified toner cartridge.</p> <p>Press <b>Go</b> to clear the message and continue printing. The supplies message is displayed on the second line of the operator panel until you replace the specified toner cartridge.</p>

## Paper Jam Messages

The following illustration lists the paper jam messages indicating where the paper jam occurred.

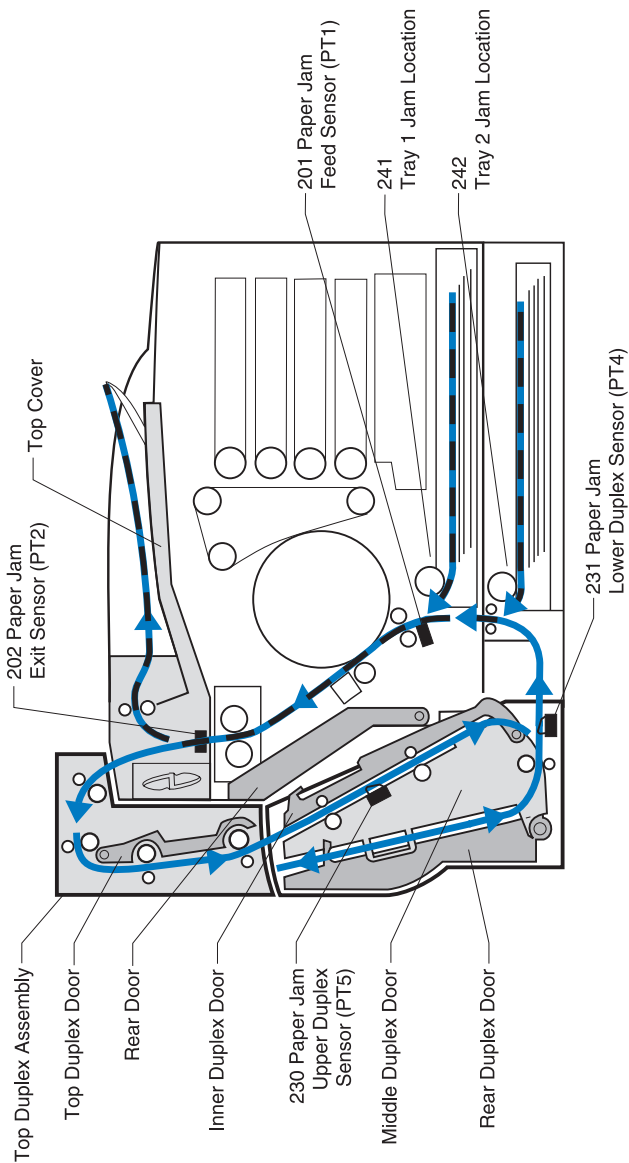

Message	To locate the jam...	For details see...
<p>201 Paper Jam</p> <p>Open Rear Door</p>	<p>Open the rear door</p>	<p>201 paper is jammed in the inner transport area or at the drum.</p> <ol style="list-style-type: none"> <li>1. Open the printer rear door.</li> <li>2. Check the paper feed sensor (PT1) and its actuators. Ensure connector DCN4 on the IDO1 P.W.B. board is connected. Replace the IDO1 P.W.B. board, if necessary.</li> <li>3. If necessary, replace the main engine (MCTL P.W.B.) board, as necessary. Go to the <b>“Paper Feed Service Checks” on page 2-77</b>, for more information.</li> </ol> <p><b>Note:</b> Clear all paper from the paper path.</p> <p><b>CAUTION:</b> The inside of the printer may be hot. Allow the printer to cool before touching any internal components.</p>



Message	To locate the jam...	For details see...
<p>202 Paper Jam</p> <p>Open Top Cover</p>	<p>Open the top cover</p>	<p>202 paper jammed in the fuser or paper exit rollers.</p> <ol style="list-style-type: none"> <li>1. Open the top cover and rear door, remove the paper.</li> <li>2. Check the actuator and the paper exit sensor (PT2). Ensure the connector DCN14 on the IDO1 P.W.B. board is connected. Replace the IDO1 P.W.B. board, if necessary.</li> <li>3. If necessary, replace the main engine (MCTL P.W.B.) board, as necessary. Go to <b>“Paper Feed Service Checks” on page 2-77</b>, for more information.</li> </ol> <p><b>Note:</b> Clear all paper from the paper path.</p> <p><b>CAUTION:</b> The inside of the printer may be hot. Allow the printer to cool before touching any internal components.</p>

Message	To locate the jam...	For details see...
<p>202 Paper Jam Open Top Cover</p> <p>and</p> <p>85 Fuser Exhausted</p>	<p>Open the top cover</p>	<p>202 / 85 the fuser is exhausted or the fuser is in a maintenance state which may cause a re-occurring 201 paper jam.</p> <ol style="list-style-type: none"> <li>1. Open the top cover and rear door, remove the paper.</li> <li>2. Check the details for error 201 and, if paper jam re-occurs in the fuser, the fuser needs to be replaced (customer ordered).</li> </ol> <p><b>Notes:</b></p> <ul style="list-style-type: none"> <li>– Paper jammed in the fuser rollers must be removed from the back of the printer to avoid contaminating the fuser rollers with unfused toner.</li> <li>– Clear all paper from the paper path.</li> </ul>
<p>230 Paper Jam  Duplex Top Door</p>	<p>Open the duplex unit top door</p>	<p>230 check the duplex upper paper sensor (PT5) and actuator.</p> <ol style="list-style-type: none"> <li>1. Ensure connector CN2 on the duplex relay P.W.B. board is plugged in.</li> <li>2. Replace the duplex relay P.W.B. board if necessary.</li> </ol> <p>Go to <b>“Duplex Paper Feed Service Check”</b> on page 2-81, for more information.</p> <p><b>Note:</b> Clear all paper from the paper path.</p>

Message	To locate the jam...	For details see...
<p>231 Paper Jam</p> <p>Duplex Low Door</p>	<p>Open the duplex unit lower door</p>	<p>231 check the duplex lower paper sensor (PT4) and actuator. Ensure connector CN6 on the duplex relay P.W.B. Board is plugged in.</p> <p>Replace the duplex relay P.W.B. board if necessary. If the paper jam still exists, go to <b>“Duplex Paper Feed Service Check” on page 2-81.</b></p> <p><b>Note:</b> Clear all paper from the paper path.</p>
<p>24x Paper Jam</p> <p>Check Tray x</p>	<p>Open the paper tray</p>	<p>24x paper jam around (tray 1 or 2)</p> <p><b>Notes:</b></p> <ul style="list-style-type: none"> <li>– If the tray is difficult to remove, remove the tray above or below trays to remove jammed pages.</li> <li>– Ensure no paper is jammed at the pickup roll.</li> <li>– If clearing paper doesn't resolve the problem and you have a 241 error, go to <b>“Paper Feed Service Checks” on page 2-77.</b> If you have a 242 error, go to <b>“Lower Feed Unit Paper Feed Service Check” on page 2-79.</b></li> </ul> <p><b>CAUTION:</b> The inside of the printer may be hot. Allow the printer to cool before touching any internal components.</p>

## Symptom Tables

### Printer Symptom Table

Symptom	Action
Operator Panel buttons do not work	Go to <b>“Operator Panel Service Check” on page 2-70.</b>
Operator Panel display is blank, printer beeps 5 times	Go to <b>“Operator Panel Service Check” on page 2-70.</b>
Operator Panel continuously displays all diamonds and beeps 5 times	Go to <b>“Operator Panel Service Check” on page 2-70.</b>
Operator Panel display is blank, but printer does not beep	Replace the operator panel assembly.
Paper Feed problem with the base printer, including paper jam 201 and 202	Go to <b>“Paper Feed Service Checks” on page 2-77.</b>  23x see <b>“Duplex Paper Feed Service Check” on page 2-81.</b>  24x see <b>“Lower Feed Unit Paper Feed Service Check” on page 2-79.</b>
Close Door displayed when all doors are closed	Go to <b>“Operator Messages” on page 2-9</b> and follow the action to be taken.
Printer does not reset or change User Settings	Go to <b>“Operator Messages” on page 2-9</b> and follow the action to be taken.
Paper Jam Messages do not reset after removing paper	Go to <b>“Operator Messages” on page 2-9</b> and follow the action to be taken.
Toner Cartridge does not turn or does not put toner on the OPC Belt Cartridge	Go to <b>“Toner Feed Service Check” on page 2-75.</b>
The Developer Motor (DM) makes noise or continuously runs	Go to <b>“910—Developer Motor (DM) Drive Service Check” on page 2-45.</b>

Symptom	Action
The Main Motor (MM) makes noise or continuously runs	Go to <b>“911—Main Motor (MM) Service Check”</b> on page 2-47.
The Transfer Drum is making noise when rotated or it does not rotate at all	Go to <b>“990—Transfer Drum Encoder Sensor (HPSEN) Service Check”</b> on page 2-61.
The Transfer roll is not transferring images or does not turn	Go to <b>“White Band Service Check”</b> on page 2-100.
No power	Go to <b>“Printer No Power Service Check”</b> on page 2-74.
Waste Toner Feed problems	<b>“Waste Toner Feed Service Check”</b> on page 2-76.
Fans not working or making noise	See <b>“Service Error Codes”</b> on page 2-2. Find the failing fan and follow the action to be taken.
Paper does not separate from Transfer Drum	Go to <b>“Paper Discharge Service Check”</b> on page 2-73.
Print/Image problems	Go to <b>“Print Quality Symptom Table”</b> on page 2-34.
Printer does not stop when Exit Tray is full	Go to <b>“Operator Messages”</b> on page 2-9.
OPC Belt Cartridge does not rotate or makes noise	Go to <b>“OPC Belt (Photo Developer) Cartridge Drive Service Check”</b> on page 2-70.
Wrong Color Print	Ensure the developer clutch connectors (DCLK, DCLY, DCLM, DCLC) on the IOD2 P.W.B. board are plugged into the correct position.  <b>Note:</b> See the wiring diagram for proper connection.

## Print Quality Symptom Table

Symptom	Action
Background	Go to <b>“Background Service Check”</b> on page 2-83.
Missing Image at Edge	Go to <b>“Missing Image at Edge Service Check”</b> on page 2-91.
Jitter	Go to <b>“Jitter Service Check”</b> on page 2-90.
Ribbing	Go to <b>“Ribbing Service Check”</b> on page 2-95.
Wrinkle and Image Migration	Go to <b>“Wrinkle / Image Migration Service Check”</b> on page 2-105.
White Line	Go to <b>“White Line I Service Check”</b> on page 2-101.
White Line	Go to <b>“White Line II Service Check”</b> on page 2-102.
Vertical White Band	Go to <b>“Vertical White Band Service Check”</b> on page 2-99.
Black Line	Go to <b>“Black Line Service Check”</b> on page 2-86.
Vertical Line	Go to <b>“Vertical Line Service Check”</b> on page 2-97.
Vertical Staggering Image	Go to <b>“Vertical Staggering Image Service Check”</b> on page 2-98.
Banding	Go to <b>“Banding Service Check”</b> on page 2-85.
White Band	Go to <b>“White Band Service Check”</b> on page 2-100.
Toner Drop	Go to <b>“Toner Drop Service Check”</b> on page 2-96.
White Spots and Black Spots	Go to <b>“White Spot / Black Spot Service Check”</b> on page 2-103.
Mixed Color Image	Go to <b>“Mixed Color Image Service Check”</b> on page 2-92.

<b>Symptom</b>	<b>Action</b>
Color Misregistration	Go to <b>“Color Misregistration Service Check”</b> on page 2-87.
Mottle	Go to <b>“Mottle Service Check”</b> on page 2-93.
Residual Image	Go to <b>“Residual Image Service Check”</b> on page 2-94.
Insufficient Gloss	Go to <b>“Insufficient Gloss Service Check”</b> on page 2-89.
Back stain	Go to <b>“Back Stain Service Check”</b> on page 2-84.
White Print	Go to <b>“White Print Service Check”</b> on page 2-104.
Insufficient Fusing	Go to <b>“Insufficient Fusing Service Check”</b> on page 2-88.

## Optional Lower Feed Unit Symptom Table

Symptom	Action
No power	Go to <b>“Options No Power Service Check”</b> on page 2-72.
Paper Feed problem in Lower Feed Unit	Go to <b>“Lower Feed Unit Paper Feed Service Check”</b> on page 2-79.
Printer does not clear or reset Operator Messages	Go to <b>“Operator Messages”</b> on page 2-9 and follow action to be taken.
Paper Stop half in exit of Duplex Unit and entrance of the Lower Feed Unit	Go to <b>“Lower Feed Unit Paper Feed Service Check”</b> on page 2-79.
Paper Jam 241, 242, 231	Go to <b>“Operator Messages”</b> on page 2-9 and follow action to be taken.



## Optional Duplex Unit Symptom Table

Symptom	Action
Printer does not clear or reset Operator Messages or controls for Duplex Unit	Go to <b>“Operator Messages” on page 2-9</b> and follow action to be taken.
Paper Feed problems for Duplex Unit	Go to <b>“Duplex Paper Feed Service Check” on page 2-81.</b>
Paper Jam error code 231, 230	Go to <b>“Operator Messages” on page 2-9</b> and follow action to be taken.
No power	Go to <b>“Options No Power Service Check” on page 2-72.</b>
Duplex Unit fails to move paper through, into or out of the Duplex Unit.  Activates something during POR.	Go to <b>“981—Duplex Motor (DPM1, DPM2) Service Check” on page 2-56.</b>
Paper fails to enter Duplex Unit from Fuser	Go to <b>“982—Duplex Upper Solenoid (DSOL-U) Service Check” on page 2-58.</b>  Go to <b>“Duplex Paper Feed Service Check” on page 2-81.</b>
Duplex Fan does not come on	Go to <b>“983— Duplex Fan (D-FAN) Service Check” on page 2-59.</b>
Paper fails to re-enter printer	Go to <b>“984—Duplex Lower Solenoid (DSOL-L) Service Check” on page 2-60.</b>  Go to <b>“Duplex Paper Feed Service Check” on page 2-81.</b>

## Printer Service Checks

### 901—Yellow Developer Clutch Service Check

	FRU	Action
1	Check Connector	Ensure the DCLY connector ENC14 on the IOD2 P.W.B. board is firmly connected.  Connect if necessary.
2	Yellow Developer Clutch (DCLY)	Check the voltage between ECN14-3 and ECn2-6 on the IOD2, P.W.B. board.  If the voltage drops below +24V, replace the yellow developer clutch DCLY.
3	IOD2 P.W.B. Board	Check the voltage between ECN1-3 and ECN2-8 on the IOD2 P.W.B. board.  If the voltage jumps to +24V, replace the IOD2 P.W.B. board.
4	Main Engine (MCTL P.W.B.) Board	If this does not correct the problem, replace the main engine (MCTL P.W.B.) board.

#### Developer Clutch (DCLY)

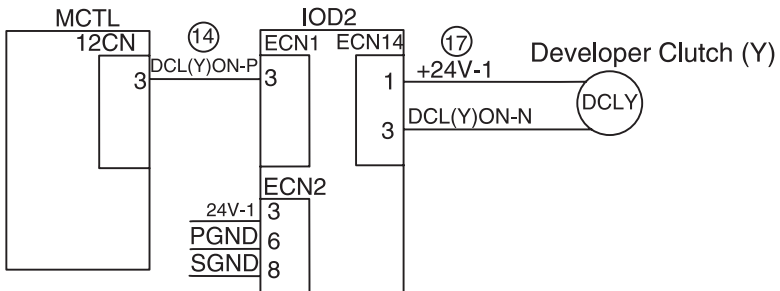

## 902—Magenta Developer Clutch Service Check

	FRU	Action
1	Check Clutch	Ensure the magenta developer clutch (DCLM) connector ECN15 on the IOD2 P.W.B. board is firmly connected.
2	Magenta Developer Clutch (DCLM)	Check the voltage between ECN15-3 and ECN2-6 on the IOD2 P.W.B. board.  If the voltage drops below +24V, replace the magenta developer clutch (DCLM).
3	IOD2 P.W.B. Board	Check the voltage between ECN1-2 and ECN2-8 on the IOD2 P.W.B. board.  If the voltage jumps to +24V, replace the IOD2 P.W.B. board.
4	Main Engine (MCTL P.W.B.) Board	If the problem still exists, replace the main engine (MCTL P.W.B.) board.

### Developer Clutch (DCLM)

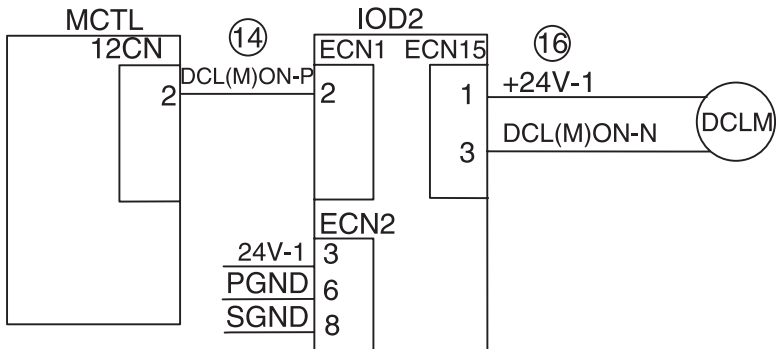

### 903—Cyan Developer Clutch Service Check

	FRU	Action
1	Check Clutch	Ensure the cyan developer clutch (DCLC) connector ECN16 on the IOD2 P.W.B. board is properly connected.
2	Cyan Developer Clutch (DCLC)	Check the voltage between ECN16-3 and ECN2-6 on the IOD2 P.W.B. board.  If the voltage drops below +24V, replace the Cyan Developer (DCLC).
3	IOD2 P.W.B. Board	Check the voltage between ECN1-1 and ECN2-8 on the IOD2 P.W.B. board.  If the voltage jumps to +24V, replace the IOD2 P.W.B. board.
4	Main Engine (MCTL P.W.B.) Board	If the problem still exists, replace the main engine (MCTL P.W.B.) board.

#### Developer Clutch (DCLC)

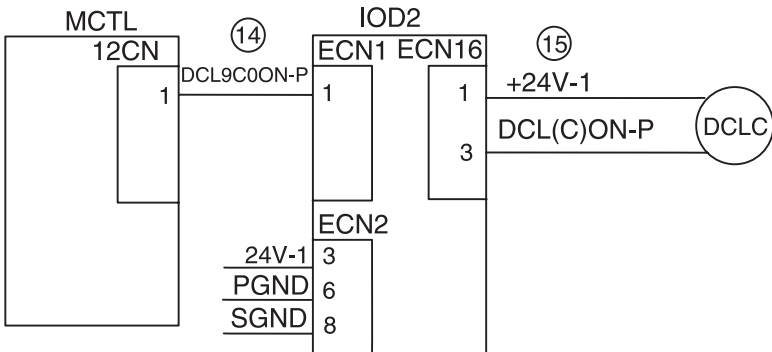

## 904—Black Developer Clutch Service Check

	FRU	Action
1	Check Clutch	Ensure the black developer clutch (DCLK) connector ECN13 on IOD2 P.W.B. board is properly connected.
2	Black Developer Clutch (DCLK)	Check the voltage between ECN13-3 and ECN2-6.  If the voltage drops below +24V, replace the black developer clutch (DCLK).
3	IOD2 P.W.B. Board	Check the voltage between ECN1-4 and ECN2-8.  If the voltage does not jump to +24V, replace the IOD2 P.W.B. board.
4	Main Engine (MCTL P.W.B.) Board	If the problem still exists, replace the main engine (MCTL P.W.B.) board.

### Developer Clutch (DCLK)

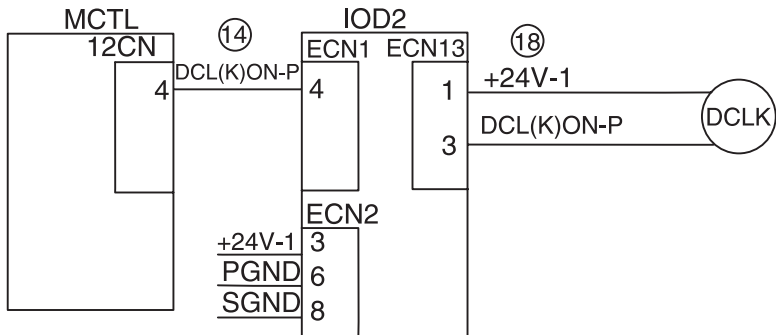

## 905—Yellow/Black Developer Solenoid Service Check

	FRU	Action
1	Check Connector  Check Cable Harness	Ensure the black/yellow solenoid connector ECN5 on the IOD2 P.W.B. board is connected.  Ensure the cable harness for the solenoid (PSL KY) is not broken.  Replace any damaged parts.
2	Developer Solenoid Assembly (PSL KY/ MC)  Front Cover Unit	Check the voltage at (PSL KY) ON-N.  Does the voltage drop below +24V between ECN5-10 and ECN2-6?  <ul style="list-style-type: none"> <li>• If the voltage drops below +24V, replace the DE solenoid assembly.</li> <li>• If this doesn't fix the problem, replace the front cover unit.</li> </ul>
3	IOD2 P.W.B. Board	Check the voltage between ECN1-5 and ECN2-8.  If the voltage jumps to +24V, replace the IOD2 P.W.B. board.
4	Main Engine (MCTL P.W.B.) Board	If the problem still exists, replace the main engine (MCTL P.W.B.) board.

### Developer Solenoid (PSL KY)

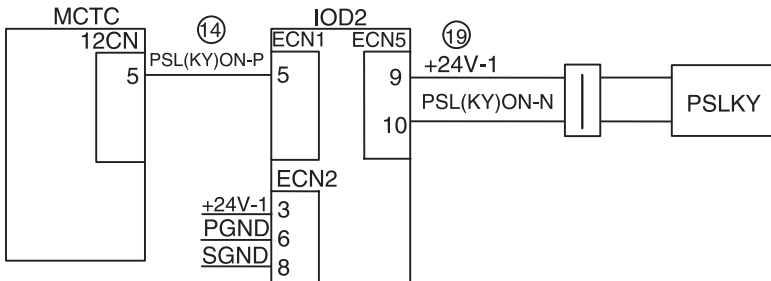

## 906—Magenta/Cyan Developer Solenoid Service Check

	FRU	Action
1	Check Connector Check Cable Harness	Ensure the magenta/cyan solenoid connector ECNS on the IOD2 P.W.B. board is connected.  Ensure the cable harness for (PSL MC) is not broken.  Replace any damaged parts.
2	Developer Solenoid Assembly (PSL KY/MC) Front Cover Unit	Check the voltage at (PSL MC) ON-N.  Does the voltage drop below +24V between ECN5-7 and ECN2-6?  <ul style="list-style-type: none"> <li>• If the voltage drops below +24V, replace the DE solenoid assembly.</li> <li>• If this does not fix the problem, replace the front cover unit.</li> </ul>
3	IOD2 P.W.B. Board	Check the voltage between ECN1-6 and ECN2-8.  If the voltage jumps to +24V, replace the IOD2 P.W.B. board.
4	Main Engine (MCTL P.W.B.) Boards	If the problem still exists, replace the main engine (MCTL P.W.B.) board.

### Developer Solenoid (PSL MC)

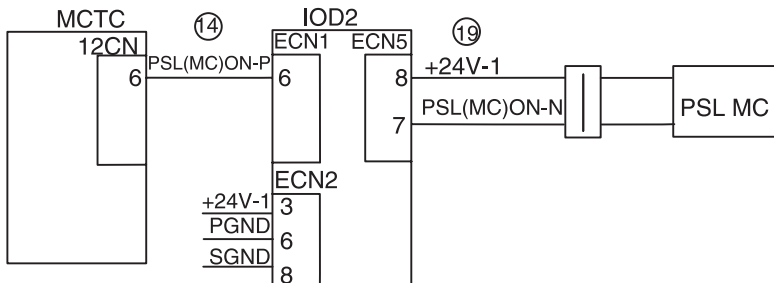

**907—Toner Empty Sensor P.W.B. Board Service Check**

	FRU	Action
1	Check Connector	Ensure the toner empty sensor (LED) connector is connected correctly to DCN7 on IOD1 P.W.B. board.
2	<ul style="list-style-type: none"> <li>• Toner Sensor, P.W.B. Board (LED side)</li> <li>• IOD1 P.W.B. Board</li> </ul>	<p>Check the voltage for (LEDON-N/D)</p> <p>If the voltage jumps to +24V between DCN7-7 and DCN7-9 on the IOD1 P.W.B. board, replace the toner sensor P.W.B. board.</p> <p>If the voltage drops to less than +24V between DCN1-15 and DCN1-41 on the IOD1 P.W.B. board, replace the IOD1 P.W.B. board.</p>
3	Main Engine (MCTL P.W.B.) Board	If the error still exists, replace the main engine (MCTL P.W.B.) board.

**Toner Sensor P.W.B. (LED side)**

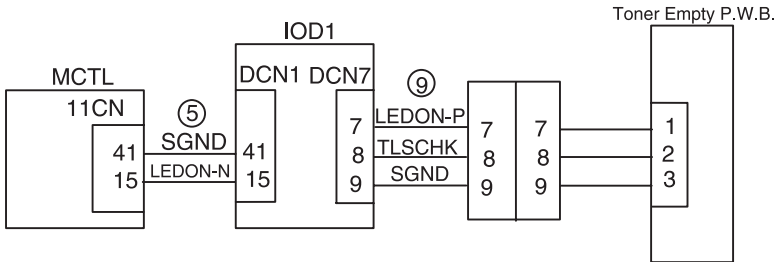



## 910—Developer Motor (DM) Drive Service Check

	FRU	Action
1	<ul style="list-style-type: none"> <li>• Toner Cartridge</li> <li>• Developer Gear Unit</li> <li>• Developer Motor</li> </ul>	<p>If any unusual rotation noise is heard while printing, check the toner cartridge and replace, if necessary.</p> <p>If the noise continues after the toner cartridge is replaced, check the developer gear unit by manually turning the motor.</p> <ul style="list-style-type: none"> <li>• If any damage to the gears is found, replace the developer gear drive unit.</li> <li>• If the noise continues, replace the developer drive motor (DM).</li> </ul>
2	Cable and Connectors	<p>If the developer motor does not turn On:</p> <ul style="list-style-type: none"> <li>• Ensure the connector DCN9 on the IOD1 P.W.B. board and the connector for the developer motor are completely connected.</li> <li>• Ensure connectors DCN1 on the IOD1 and 11CN on the main engine (MCTL P.W.B.) board are completely connected.</li> <li>• Replace any damaged parts.</li> </ul>
3	Developer Motor (DM)	<p>Check for +24V between DM1-4 and DM1-6</p> <ul style="list-style-type: none"> <li>• DCN9-4 and DCN9-6</li> <li>• DCN10-3 and DCN10-4</li> </ul> <p>Check for +5V between</p> <p>DM1-5 and DM1-9</p> <ul style="list-style-type: none"> <li>• DCN9-5 and DCN9-9</li> <li>• DCN10-7 and DCN-9</li> </ul> <p>If either +24V or +5V is found while checking these connectors, replace the developer motor (DM).</p>

	FRU	Action
4	<ul style="list-style-type: none"> <li>• IOD2 P.W.B. Board</li> <li>• IOD1 P.W.B. Board</li> <li>• Main Engine (MCTL P.W.B.) Board</li> </ul>	<p>If after replacing the developer motor the problem still exists, replace in the following order until the problem is resolved:</p> <ul style="list-style-type: none"> <li>• IOD2 P.W.B. board</li> <li>• IOD1 P.W.B. board</li> <li>• Main engine (MCTL P.W.B.) board</li> </ul>

**Developer Motor (DM)**

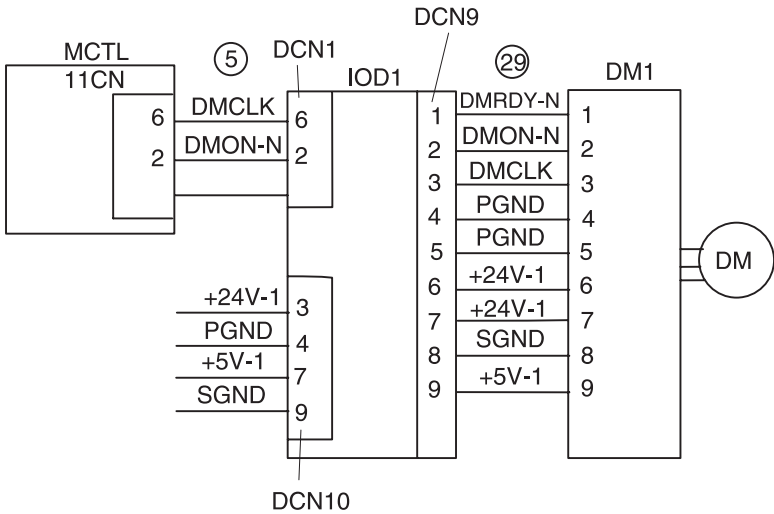

## 911—Main Motor (MM) Service Check

	FRU	Action
1	OPC Belt Print Cartridge	<p>Check the OPC belt cartridge for any rotation.</p> <p>If the main motor (MM) attempts to turn but the OPC belt cartridge does not, replace the OPC belt cartridge.</p> <p><b>Note:</b> The OPC belt cartridge is a customer order supply.</p>
2	Fuser Unit	<p>Check the fuser for any rotation.</p> <p>If the main motor (MM) attempts to turn but the fuser does not, replace the fuser unit.</p> <p><b>Note:</b> The fuser unit is a customer order supply.</p>
3		<p>If an '82 PC Missing' error is displayed, while diagnosing the main motor (MM), ensure the connector (CN1) on the main motor (MM) and connector ECN12 on the IOD2 P.W.B. board are firmly connected.</p> <p>Ensure the connectors ECN1, ECN2 on the IOD2 P.W.B. board, DCN10 on the IOD1 and 12CN on the main engine (MCTL P.W.B.) board are firmly connected.</p> <p>Replace any damaged part.</p>

	FRU	Action
4	Main Motor (MM)	<p>Check for +24V between:</p> <p>MM1-4 and MM1-5.</p> <ul style="list-style-type: none"> <li>• ECN12-4 and ECN12-5</li> <li>• ECN2-5 and ECN2-1</li> </ul> <p>If there is +24V, replace the main motor (MM).</p> <p>Check for +5V between:</p> <ul style="list-style-type: none"> <li>• MM1-6 and MM1-7</li> <li>• ECN12-6 and ECN12-7</li> <li>• ECN2-7 and ECN2-1</li> </ul> <p>If there is +5V, replace the main motor (MM).</p>
5	<ul style="list-style-type: none"> <li>• IOD2 P.W.B. Board</li> <li>• IOD1 P.W.B. Board</li> <li>• Main Engine (MCTL P.W.B.) Board</li> </ul>	<p>If the problem still exists, replace the following parts in the following order one at a time, until the problem is resolved.</p> <ul style="list-style-type: none"> <li>• IOD2 P.W.B. board</li> <li>• IOD1 P.W.B. board</li> <li>• Main engine (MCTL P.W.B.) board</li> </ul>

Main Motor (MM)

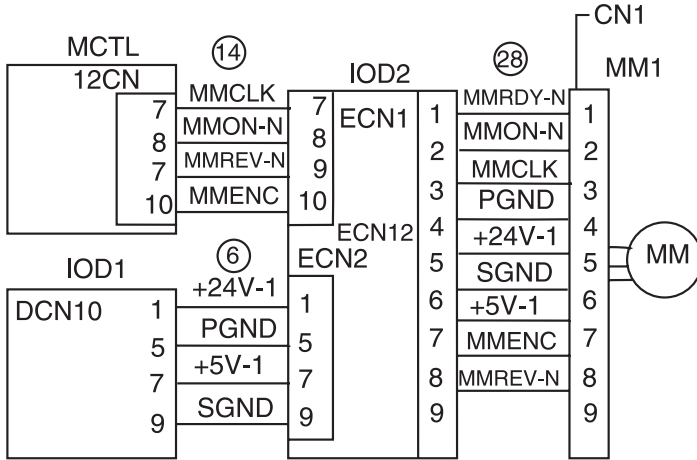

## 915—Control Cooling Fan Service Check

	FRU	Action
1	Check Connector	Ensure the control cooling fan motor is properly connected to DCN18 on the IOD1 P.W.B. board.  Check that DCN1 or the IOD1 P.W.B. board and 11CN on the main engine (MCTL P.W.B.) board are connected.
2	Control Cooling Fan Motor (CTFAN)	Check the voltage between DCN18-1 and DCN18-2 on the IOD1 P.W.B. board.  If the voltage drops to less than +24V, replace the control cooling fan (CTFAN).
3	IOD1 P.W.B. Board	Check the voltage between DCN1-33 and DCN1-44 on the IOD1 P.W.B. board.  If the voltage drops to less than +24V, replace the IOD1 P.W.B. board.
4	Main Engine (MCTL P.W.B.) Board	If the problem still exists, replace the main engine (MCTL P.W.B.) board.

### Fan Motor (Control Cooling)

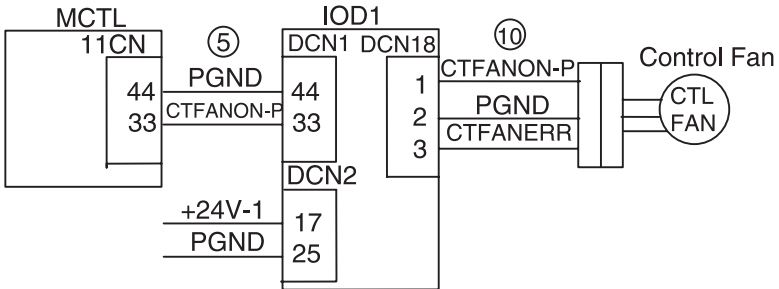

## 916—Ozone Fan Service Check

	FRU	Action
1	Check Connector	<p>Ensure the ozone fan motor connector is properly connected to ECN5 on the IOD2 P.W.B. board.</p> <p>Ensure connectors ECN1 on the IOD2 P.W.B. board and 12CN on the main engine (MCTL P.W.B.) board are properly connected.</p>
2	<p>Ozone Fan Motor (OZFAN)</p> <p>IOD2 P.W.B. Board</p>	<p>Check the voltage between ECN3-1 and ECN3-2 on the IOD2 P.W.B. board.</p> <p>If the voltage is +24V, replace the ozone fan (OZFAN).</p> <p>Check the voltage between ECN1-9 and ECN2-8 on the IOD2 P.W.B. board.</p> <p>If the voltage is less than +24V, replace the IOD2 P.W.B. board.</p>
3	Main Engine (MCTL P.W.B.) Board	If the problem still exists, replace the main engine (MCTL P.W.B.) board.

### Fan Motor OZFAN

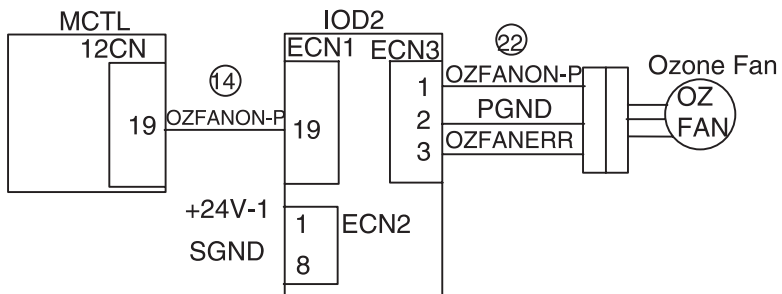

## 917—Fuser Heater Fan Service Check

	FRU	Action
1	Check Connector	<p>Ensure the fuser heater fan motor connector is properly connected to DCN14 on the IOD1 P.W.B. board.</p> <p>Ensure DCN1 on the IOD1 P.W.B. board and 11CN on the main engine (MCTL P.W.B.) board are connected properly.</p>
2	Fuser Heater Fan (HTFAN)	<p>Check the voltage between DCN14-10 and DCN14-11.</p> <p>If the voltage is +24V, replace the fuser heater fan (HTFAN).</p>
3	IOD1 P.W.B. Board	<p>Check the voltage between DCN1-35 and DCN1-44.</p> <p>If the voltage is +24V, replace the IOD1 P.W.B. board.</p>
4	Main Engine (MCTL P.W.B.) Board	<p>If the problem still exists, replace the main engine (MCTL P.W.B.) board.</p>

### Heater Fan HTFAN

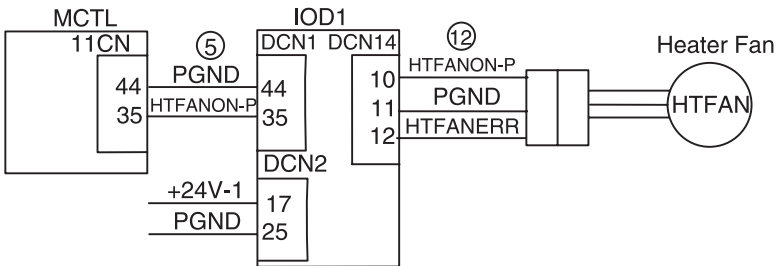



## 918—Erase Lamp Service Check

	FRU	Action
1	Check Connector	<p>Ensure the erase lamp connector is properly connected to DCN7 on the IOD1 board.</p> <p>Ensure DCN1 on the IOD1 board and 11CN on the main engine (MCTL P.W.B.) board are connected.</p>
2	Erase Lamp (LED P.W.B.)	<p>Check for voltage between DCN7-11 and DCN2-25 on the IOD1 board.</p> <ul style="list-style-type: none"> <li>• If the voltage drops to less than +24V, replace the erase lamp (LED P.W.B.).</li> </ul>
3	<ul style="list-style-type: none"> <li>• IOD1 P.W.B. Board</li> <li>• Main Engine (MCTL P.W.B.) Board</li> </ul>	<p>Check for voltage between DCN1-27 and DCN1-44 on the IOD2 P.W.B. board.</p> <ul style="list-style-type: none"> <li>• If the voltage jumps to +24V, replace the IOD1 P.W.B. board.</li> </ul> <p>If the problem still exists, replace the main engine (MCTL P.W.B.) board.</p>

### Erase Lamp EL

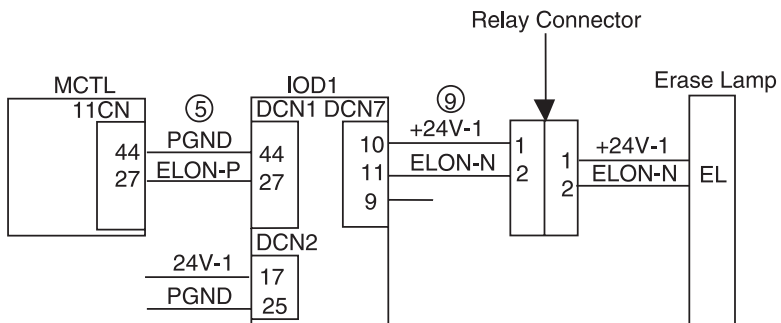

## 920, 922, 923—Fuser Unit Service Check

	FRU	Action
1	Fuser Unit	<p>Check for dirt or any damage to the fuser unit and replace, if necessary.</p> <p>Turn the machine on and determine whether the fuser heater is On.</p> <p>If the heater lamp is On, check for the correct input line voltage.</p> <p>If the line voltage is correct and the error still exists, replace the fuser unit.</p> <p><b>Note:</b> The fuser unit is a customer order supply.</p>
2	<ul style="list-style-type: none"> <li>• Fuser Low Voltage Power Supply (LVPS)</li> <li>• Main Engine (MCTL P.W.B.) Board</li> </ul>	<p>Turn the machine On and determine whether the fuser is On.</p> <p>If the heater lamp is Off, check the following:</p> <ul style="list-style-type: none"> <li>• Ensure the fuser is installed properly.</li> <li>• Ensure the fuser connector is not damaged and replace, if necessary.</li> </ul> <p>If the problem still exists, replace the following parts in the order given until the error is cleared.</p> <ul style="list-style-type: none"> <li>• Fuser unit</li> </ul> <p><b>Note:</b> The fuser unit is a customer order supply.</p> <ul style="list-style-type: none"> <li>• Low voltage power supply (LVPS)</li> <li>• Main engine (MCTL P.W.B.) board</li> </ul>

## 921—Fuser Thermistor Service Check

	FRU	Action
1	Fuser Unit	<p>Ensure the fuser is properly installed.</p> <p>If the fuser is damaged, replace the fuser unit.</p> <p><b>Note:</b> The fuser unit is a customer order supply.</p>
2	Fuser Connector	Check the fuser connector for damage and replace, if necessary.
3	<ul style="list-style-type: none"> <li>• Fuser Unit</li> <li>• IOD1 P.W.B. Board</li> <li>• Main Engine (MCTL P.W.B.) Board</li> </ul>	<p>Ensure the fuser connector, FUCN, to the main engine (MCTL P.W.B.) board is properly connected.</p> <p>If the problem still exists, replace the following parts in the order given until the error is cleared.</p> <ul style="list-style-type: none"> <li>• Fuser unit</li> <li>• IOD1 P.W.B. board</li> <li>• Main engine (MCTL P.W.B.) board</li> </ul>

### HO Fuser Unit

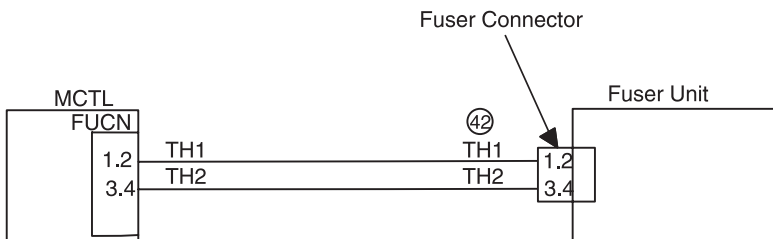

## 981—Duplex Motor (DPM1, DPM2) Service Check

	FRU	Action
1	Gears, Belts, Rollers	<p>Check the duplex drive train for binds or broken gears, belts or rollers.</p> <p>Replace any damaged parts.</p>
2	<ul style="list-style-type: none"> <li>• Duplex Motor (DPM1)</li> <li>• Duplex P.W.B. Board</li> </ul>	<p>Check the resistance of the duplex motors (DPM1).</p> <p>If the resistance is approximately 7 ohms between:</p> <ul style="list-style-type: none"> <li>• The duplex motor 1 (DPM1) connector CN5-1 and               <ul style="list-style-type: none"> <li>– CN5-2</li> <li>– CN5-3</li> <li>– CN5-4</li> </ul> </li> <li>• Replace the duplex (DUP P.W.B.) board.</li> </ul> <p>If the resistance is not approximately 7 ohms, replace the duplex motor 1 (DUP1).</p>
3	<ul style="list-style-type: none"> <li>• Duplex Motor 2 (DPM2)</li> <li>• Duplex P.W.B. Board</li> </ul>	<p>Check the resistance for duplex motor 2 (DPM2).</p> <p>If the resistance is approximately 7 ohms between:</p> <ul style="list-style-type: none"> <li>• The duplex motor 2 (DPM2) connector CN7-1 and               <ul style="list-style-type: none"> <li>– CN7-2</li> <li>– CN7-3</li> <li>– CN7-4</li> </ul> </li> <li>• Replace the duplex (DUP P.W.B.) board.</li> </ul> <p>If the resistance is not approximately 7 ohms, replace the duplex motor 2 (DPM2).</p>

# Duplex Motor (DPM1, DPM2)

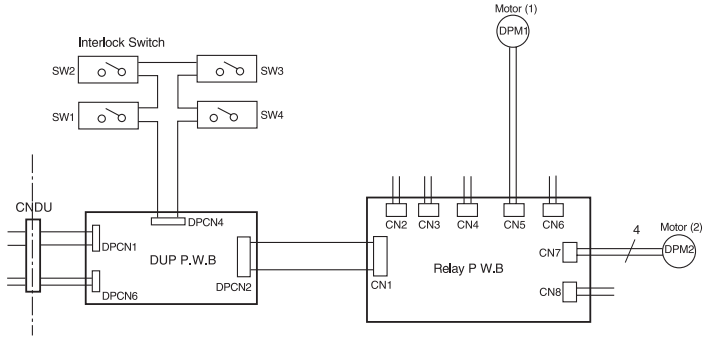

## 982—Duplex Upper Solenoid (DSOL-U) Service Check

	FRU	Action
1	Check Connector	<p>Ensure connector, CN8, is connected properly between the duplex upper solenoid DSOL and duplex relay P.W.B. board.</p> <p>Ensure connector, CN1, on the relay P.W.B. board is connected properly with DPCN2 on the duplex P.W.B. board.</p>
2	<ul style="list-style-type: none"> <li>• Duplex Upper Solenoid (DSOL-U)</li> <li>• Duplex P.W.B. Board</li> </ul>	<p>If the problem still exists, replace the duplex upper solenoid DSOL.</p> <p>If this does not correct the problem, replace the duplex P.W.B. board.</p>

### Duplex Upper Solenoid (DSOL-U)

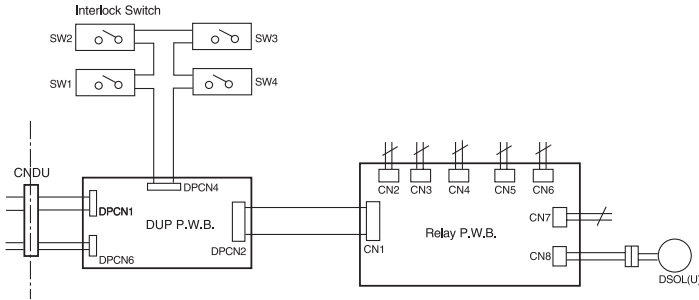

## 983— Duplex Fan (D-FAN) Service Check

	FRU	Action
	Check Connector	<p>Ensure connector CN4 is properly connected between the D-FAN and the duplex relay P.W.B. board.</p> <p>Ensure connector duplex CN1 is properly connected to DPCN3 on the duplex DUP P.W.B. board.</p>
	<ul style="list-style-type: none"> <li>• Duplex Fan (D-FAN)</li> <li>• DUP P.W.B. Board</li> <li>• Duplex Relay P.W.B. Board</li> </ul>	<p>If the problem still exists, replace the D-FAN motor, if necessary. Then replace the duplex DUP P.W.B. board and the duplex relay P.W.B. board until the problem is resolved.</p>

### Duplex Fan (D-FAN)

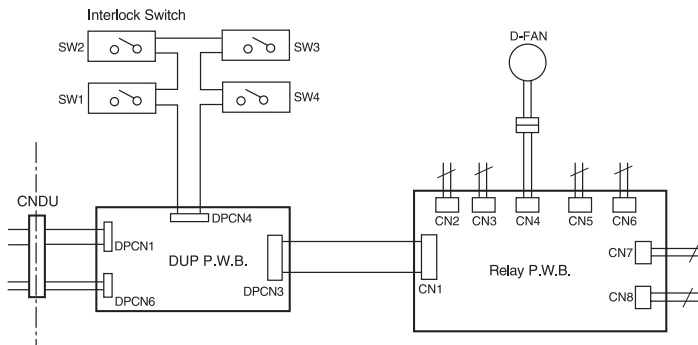

## 984—Duplex Lower Solenoid (DSOL-L) Service Check

	FRU	Action
1	Check Connector	<p>Ensure connector, CN3, is connected properly between DSOL and relay P.W.B. board.</p> <p>Ensure connector, CN1, on the relay P.W.B. board is connected properly with D-CN2 on the DUP P.W.B. board.</p>
2	<ul style="list-style-type: none"> <li>• Duplex Lower Solenoid (DSOL-L)</li> <li>• Duplex P.W.B. Board</li> <li>• Duplex Relay P.W.B. Board</li> </ul>	<p>If the problem still exists, replace the duplex lower solenoid DSOL.</p> <p>If this does not correct the problem, replace the duplex P.W.B. board and then the duplex relay P.W.B. board until the problem is resolved.</p>

### Duplex Lower Solenoid (DSOL-L)

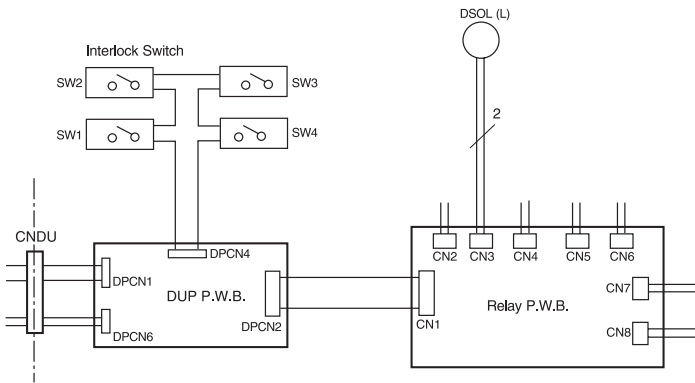



## 990—Transfer Drum Encoder Sensor (HPSEN) Service Check

	FRU	Action
1	Transfer Drum	<p>Check the OPC belt cartridge for proper installation.</p> <p>The transfer drum should rotate with little resistance.</p> <p>If the transfer drum does not rotate lightly or the encoder plate is damaged, replace the transfer drum.</p>
2	<ul style="list-style-type: none"> <li>• Transfer Drum Encoder Sensor (HPSEN)</li> <li>• IOD1 P.W.B. Board</li> <li>• Main Engine (MCTL P.W.B.) Board</li> </ul>	<p>Ensure connectors DCN4 on the IOD1 board and the transfer drum encoder sensor (HPSN) are correctly connected.</p> <p>Check for +5V between DCN4-1 and DCN1-3.</p> <ul style="list-style-type: none"> <li>• If there is +5V, replace the transfer drum encoder sensor (HPSEN)</li> <li>• Check for +5V between DCN2-1 and DCN2-4.</li> <li>• If the voltage is +5V, replace the IOD1 P.W.B. board.</li> <li>• If the problem still exists, replace the main engine (MCTL P.W.B.) board.</li> </ul>
3	Low Voltage Power Supply (LVPS)	<p>If there is less than +5V between DCN2-1 and DCN2-4, replace the low voltage power supply (LVPS).</p>

Drum HP Sensor

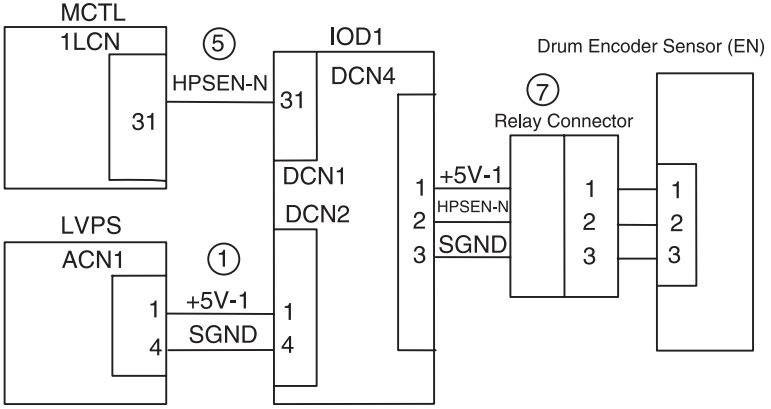

## 991—Transfer Roller Cam Clutch (TRCM) Service Check

	FRU	Action
1	Check Connector	Ensure connectors ECN8 on the IOD2 P.W.B. board is properly connected to the transfer roller cam clutch (TRCM).  Ensure ECN1 on the IOD2 P.W.B. board and 12CN on the main engine (MCTL P.W.B.) board are properly connected.
2	Transfer Roller Cam Clutch (TRCM)	Check for +24V between ECN8-4 and ECN2-5 on the IOD2 board.  If the voltage is less than +24V, replace the transfer roller cam clutch (TRCM).
3	IOD2 P.W.B. Board	Check for +24V between ECN2-5 and ECN2-18 on the IOD2 P.W.B. board.  If the voltage is less than +24V, replace the IOD2 P.W.B. board.
4	Main Engine (MCTL P.W.B.) Board	If the problem still exists, replace the main engine (MCTL P.W.B.) board.

### Transfer Cam Clutch (TRCM)

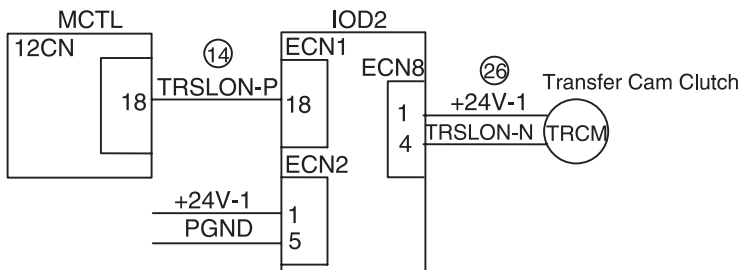

## 992—Drum Cleaner Brush Cam Clutch (FBCM) Service Check

	FRU	Action
1	Check Connector	Ensure the drum cleaner brush cam clutch (FBCM) connector and ECN10 on the IOD2 P.W.B. board are properly connected.  Ensure ECN1 on the IOD2 P.W.B. board is connected to 11CN on the main engine (MCTL P.W.B.) board.
2	Drum Cleaner Brush Cam Clutch (FBCM)	Check for +24V between ECN10-4 and ECN2-5 on the IOD2 P.W.B. board.  If the voltage is less than +24V, replace the drum cleaner brush cam clutch.
3	IOD2 P.W.B. Board	Check for +24V between ECN1-17 and ECN2-5 on the IOD2 P.W.B. board.  If the voltage jumps to +24V, replace the IOD2 P.W.B. board.
4	Main Engine (MCTL P.W.B.) Board	If the problem still exists, replace the main engine (MCTL P.W.B.) board.

### Drum Cleaner Brush Cam Clutch (FBCM)

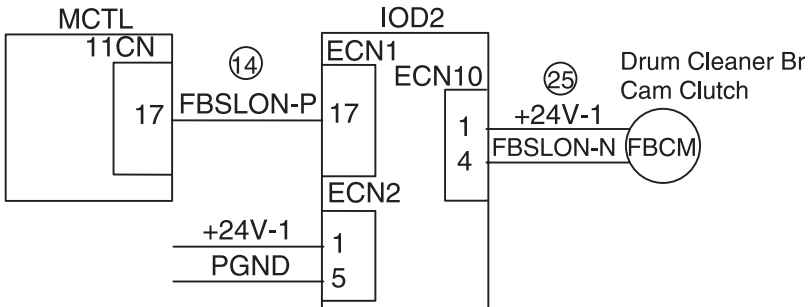

### 993—Cleaner Clutch (FBCL) Service Check

	FRU	Action
1	Check Connector	<p>Ensure ECN11 on IOD2 P.W.B. board is properly connected to the cleaner clutch (FBCL).</p> <p>Ensure ECN2 on IOD2 P.W.B. board is properly connected to DCN10 on IOD1 P.W.B. board.</p> <p>Ensure ECN1 on IOD1 is properly connected to 11CN on the main engine (MCTL P.W.B.) board.</p>
2	Cleaner Clutch (FBCL)	<p>Check for +24V between ECN11-3 and ECN2-5 on the IOD2 P.W.B. board.</p> <p>If the voltage is less than +24V, replace the cleaner clutch (FBCL).</p>
3	IOD2 P.W.B. Board	<p>Check for +24V between ECN2-5 and ECN1-16.</p> <p>If the voltage jumps to +24V, replace the IOD2 P.W.B. board.</p>
4	Main Engine (MCTL P.W.B.) Board	<p>If the problem still exists, replace the main engine (MCTL P.W.B.) board.</p>

#### Cleaner Clutch

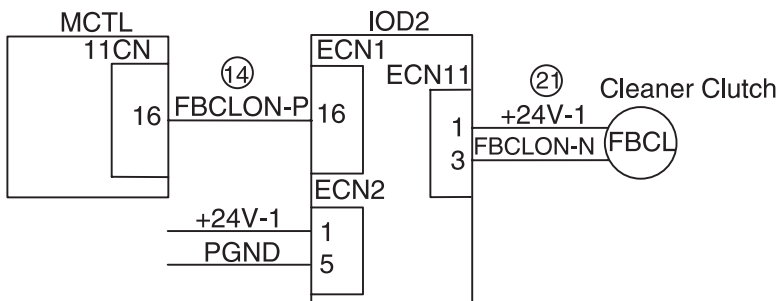

## 994—Fuser Clutch (FUCL) Service Check

	FRU	Action
1	Check Connector	Ensure a proper connection between ECN9 on IOD2 and the fuser clutch (FUCL).  Ensure ECN1 on IOD2 is properly connected to 12CN on the main engine (MCTL P.W.B.) board.
2	Cleaner Clutch (FUCL)	Check for +24V between ECN9-3 and CN2-5 on the IOD2 P.W.B. board.  If the voltage jumps to +24V, replace the cleaner clutch (FUCL).
3	IOD2 P.W.B. Board	Check for +24V between ECN1-20 and ECN2-10 on IOD2 P.W.B. board.  If the voltage jumps to +24V, replace the IOD2 P.W.B. board.
4	Main Engine (MCTL P.W.B.) Board	If the problem still exists, replace the main engine (MCTL P.W.B.) board.

### Fuser Clutch (FUCL)

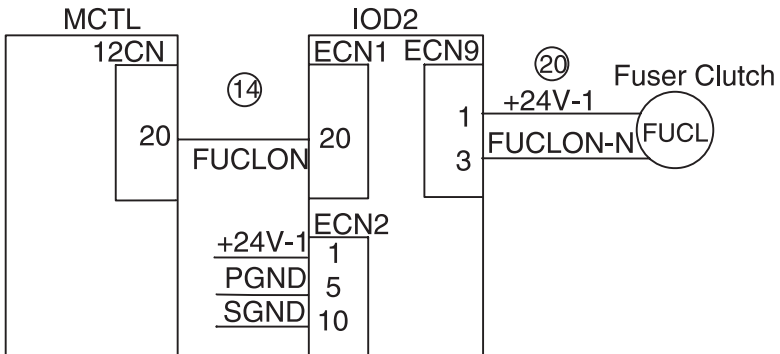

## 995—OPC Belt Cartridge, Belt Marker Sensor (PBS) Service Check

	FRU	Action
1	Belt Cartridge (OPC)	<p>Ensure the printer is level.</p> <p>If the belt sensor (PBS) is stained, clean the belt marker sensor.</p> <p>Replace the OPC belt cartridge if it is damaged or leaning to one side.</p>
2	Check Connector	<p>Ensure a proper connection between DCN16 on the IOD1 P.W.B. board and the belt marker sensor (PBS).</p> <p>Ensure a proper connection between DCN1 on the IOD1 P.W.B. board and 11CN on the main engine (MCTL P.W.B.) board.</p>
3	Belt Marker Sensor (PBS)	<p>Check for +5V between DCN16-2 and DCN16-3 on the IOD1 P.W.B. board.</p> <p>If the voltage is +5V, replace the belt marker sensor.</p> <p>Check for +5V between DCN2-1 and DCN2-4 on the IOD1 P.W.B. board.</p> <p>If the voltage is +5V, replace the IOD1 P.W.B. board.</p>
4	Main Engine (MCTL P.W.B.) Board	<p>If the problem still exists, replace the main engine (MCTL P.W.B.) board.</p>

OPC Belt Sensor (P.B.S)

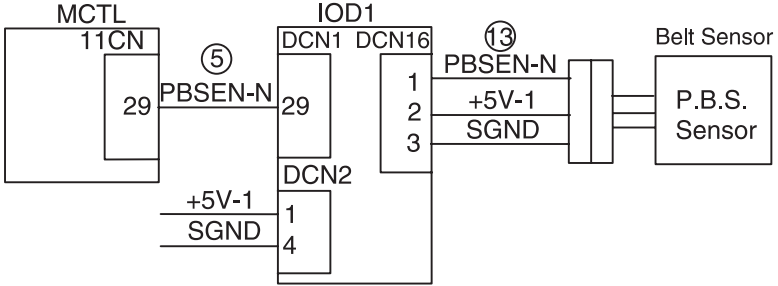



## 997—High Voltage Power Supply Unit (HVU) Service Check

	FRU	Action
1	OPC Belt Cartridge	<p>Ensure the charge unit, on the belt cartridge, is installed correctly.</p> <p>Check the charge corona wire for a cut or short.</p> <p>Replace the OPC belt cartridge, if necessary.</p> <p><b>Note:</b> This is a customer orderable part.</p>
2	High Voltage Power Supply (HVU)	<p>Turn the printer Off and unplug the power cord.</p> <p>Ensure proper contact between the high voltage power supply and all CHV output and contact terminals on the high voltage power supply (HVU).</p> <p>If any parts are dirty or damaged, clean or replace the high voltage power supply unit (HVU).</p>
3	<ul style="list-style-type: none"> <li>• IOD1 P.W.B. Board</li> <li>• Main Engine (MCTL P.W.B.) Board</li> </ul>	<p>If the problem still exists, replace the IOD1 P.W.B. board.</p> <p>If the problem is present, replace the main engine (MCTL P.W.B.) board.</p>

### High Voltage Unit HVU

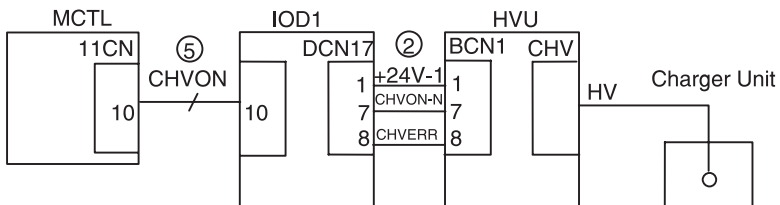

## OPC Belt (Photo Developer) Cartridge Drive Service Check

	FRU	Action
1	OPC Belt Cartridge	Check the OPC belt cartridge for damage and proper installation and replace, if necessary.
2	Belt Cartridge (BC) Lock Levers	Ensure cartridge installation guides and latches are not damaged and replace, if necessary.
3	Main Motor Board Gear Assembly	Ensure the main motor board gear assembly is not damaged and replace, if necessary.  Ensure the main gear unit is not damaged and replace, if necessary.

## Operator Panel Service Check

If the printer detects a problem with the operator panel assembly, operator panel cable, the controller RIP board or when a POR does not complete, the printer emits 5 beeps.

If the operator panel operates properly, except for a PEL or a few PEL's missing or broken, run the "LCD test" in the diagnostic mode. See "**Diagnostic Mode**" on page 3-5 for details.

	FRU	Action
1	Operator Panel Cable	Ensure the operator panel cable is plugged into the operator panel.  Ensure the operator panel cable is plugged into P2CN on the main engine (MCTL P.W.B.) board.  Ensure the control RIP board is correctly plugged in.  Check the operator panel cable for continuity. Replace if necessary.

	<b>FRU</b>	<b>Action</b>
2	<ul style="list-style-type: none"> <li>• Operator Panel Assembly</li> <li>• Main Engine (MCTL P.W.B.) Board</li> <li>• Control RIP Board</li> </ul>	<p>If the operator panel display is blank, 5 beeps are emitted and the LED is Off.</p> <p>Replace the operator panel assembly.</p> <p>If the problem still exists, replace the main engine (MCTL P.W.B.) board.</p> <p>If this does not correct the problem, replace the controller RIP board.</p>
3	<ul style="list-style-type: none"> <li>• Code SIMM</li> <li>• Controller RIP Board</li> </ul>	<p>If the operator panel has diamonds but does not beep 5 times, check the controller RIP board for proper installation.</p> <p>Verify that the memory DIMMS and the code SIMM are plugged in correctly.</p> <p>If this does not correct the problem, replace the code SIMM.</p> <p>If the problem still exists, replace the controller RIP board.</p>
4	Operator Panel Assembly	If the operator panel fails any test in the diagnostic mode, replace the operator panel.

## Options No Power Service Check

	FRU	Action
	<ul style="list-style-type: none"> <li>• Lower Feed Unit Installation Cable</li> <li>• Main Engine (MCTL P.W.B.) Board.</li> <li>• Duplex Unit Installation Cable</li>   <li>• Duplex (DUP P.W.B.) Board</li> <li>• Main Engine (MCTL P.W.B.) Board</li> <li>• Low Voltage Power Supply (LVPS)</li> </ul>	<p><b>Note:</b> If any paper handling options (250 tray or duplex unit) are installed, disconnect or remove the options and check the base printer for correct operation.</p> <p>If the printer operates correctly, reinstall one option at a time to isolate the device.</p> <p>If the lower feed unit is the problem:</p> <ul style="list-style-type: none"> <li>• Ensure the lower feed unit is connected to the printer.</li> <li>• Check that the lower feed unit installation cable for damage and replace, if necessary.</li> <li>• Ensure connector DCN8 on the main engine (MCTL P.W.B.) board is connected. Replace, if necessary.</li> </ul> <p>If the duplex unit is the problem:</p> <ul style="list-style-type: none"> <li>• Ensure the duplex unit is connected to the printer.</li> <li>• Check the duplex unit Installation Cable for damage and replace, if necessary.</li> <li>• Ensure connector DPCN, on the main engine (MCTL P.W.B.) board is connected.</li> <li>• Ensure connectors ACN4 and ACN1 on the low voltage power supply (LVPS) are connected.</li> <li>• Ensure connectors DPCN1 and DPCN6, on the duplex (DUP P.W.B.) board are connected.</li> <li>• Replace the duplex (DUP P.W.B.) board.</li> <li>• Replace the main engine (MCTL P.W.B.) board.</li> <li>• Replace the low voltage power supply (LVPS).</li> </ul>

## Paper Discharge Service Check

	FRU	Action
1	<ul style="list-style-type: none"> <li>• Paper Discharger Unit</li> <li>• Transfer Unit</li> </ul>	<p>Ensure the transfer drum is not damaged.</p> <p>Do not touch the drum as hand oil damages the surface.</p> <p>Check the paper discharger unit for damage and replace, if necessary.</p> <p>If this does not correct the problem, replace the transfer unit.</p>
2	High Voltage Power Supply (HVS)	<p>Ensure the paper discharger unit is plugged into THV on the high voltage power supply (HVU).</p> <p>If the problem still exists, replace the high voltage power supply (HVU).</p>

## Printer No Power Service Check

	FRU	Action
1	Line Voltage	<p><b>Note:</b> If any paper handling options (250 tray or duplex unit) are installed, disconnect or remove the options and check the base printer for correct operation.</p> <p>Check the line voltage. If the line voltage is incorrect, inform the customer.</p>
2	AC Line Cord	<p>Check the line cord for damage.</p> <p>Check the continuity of the line cord and replace, if necessary.</p>
3	<ul style="list-style-type: none"> <li>• Low Voltage Power Supply (LVPS)</li> <li>• Main Engine (MCTL P.W.B.) Board</li> </ul>	<p>Turn the printer Off and then back On.</p> <p>If you do not hear any activation of motors or the operator panel does not display anything:</p> <ul style="list-style-type: none"> <li>• Check for proper connection of connectors ACN12, ACN3 on the low voltage power supply (LVPS).</li> <li>• Check for proper connection of connectors POCN and 13CN on the main engine (MCTL P.W.B.) board.</li> <li>• Replace the low voltage power supply.</li> <li>• Replace the main engine (MCTL P.W.B.) board.</li> </ul>

**Toner Feed Service Check**

	<b>FRU</b>	<b>Action</b>
1	<ul style="list-style-type: none"><li>• Toner Cartridge</li><li>• Developer Drive Unit</li><li>• Developer Drive Gear</li></ul>	<p>Check for damage of the color toner cartridge.</p> <p>Check the developer drive unit gear train for damage.</p> <p>Replace parts, if necessary.</p>
2	<ul style="list-style-type: none"><li>• Developer Solenoid Assembly</li><li>• Front Cover Unit</li></ul>	<p>Check the front cover unit for damage to the DE solenoid assembly.</p> <p>If any additional damage is seen, replace the front cover unit.</p>

## Waste Toner Feed Service Check

	FRU	Action
1	Check Installation	<p>Ensure the cleaning roller is installed.</p> <p>If you are receiving an error message, go to <b>“Symptom Tables” on page 2-32</b>, for more information.</p>
2	Drum Cleaner Roll	<p>Inspect the cleaning roll for damage or paper. Clean or replace, if necessary.</p>
3	Toner Waste Holder Assembly	<p>Inspect the toner waste bottle for overflow.</p> <p>If the bottle is overflowing and no operator message is displayed, go to <b>“Operator Messages” on page 2-9</b> for checking sensors.</p> <p>If the waste toner sensors are good, inspect the waste toner assembly and replace, if necessary.</p>
4	Waste Toner Auger U Spring (Upper)	<p>Check the waste toner auger U spring for breakage or damage.</p> <p>This spring transports the waste toner from the drum cleaner roll to the waste toner bottle.</p>
5	Waste Toner Feeder (Lower)	<p>Ensure the waste toner feeder (Lower) is not damaged and the waste tube is not blocked.</p>



## Paper Feed Service Checks

### Printer Paper Feed Service Check

	FRU	Action
1	Check for Recommended Paper	<p>Ensure paper being used is a recommended.</p> <p>Ensure paper does not contain humidity.</p> <p><b>Note:</b> Disconnect the lower feed unit and the duplex unit, if installed, to help isolate a paper transport problem. See “<b>Lower Feed Unit Theory of Operation</b>” on page 1-48 and “” on page 1-50, for more information.</p>
2	<ul style="list-style-type: none"> <li>• Paper Stop</li> <li>• Paper Cassette</li> </ul>	<p>Ensure the paper cassette (Tray 1) is not damaged and the paper stop is set to the proper position.</p> <p>Check for paper caught behind the cassette, in the pickup transport roll.</p> <p>Replace any damaged parts.</p>
3	<ul style="list-style-type: none"> <li>• Paper Feed Roller</li> <li>• Separator Pad</li> </ul>	<p>Check the paper feed roller and the separator pad for wear or damage.</p> <p>Replace any damaged parts.</p>
4	<ul style="list-style-type: none"> <li>• Registration Roller</li> <li>• Transfer Roll</li> <li>• Paper Discharge Unit</li> <li>• Transfer Unit</li> </ul>	<p>Check the registration roller for damage or binds, and replace, if necessary.</p> <p>Check the transfer roll and paper discharge unit assembly for damage and replace, if necessary.</p> <p>If there is any additional damage to the transfer unit replace it.</p>
5	Transfer Drum	<p>Ensure the transfer drum is not damaged and is free of foreign material.</p> <p><b>Note:</b> Do not touch the transfer drum, with your hands, as oil may be left on the drum surface.</p>

	FRU	Action
6	Transfer Drum Cleaner	<p>Ensure no paper is jammed in the drum cleaner.</p> <p>Ensure the drum cleaner is not damaged.</p> <p>Replace the drum cleaner, if necessary.</p>
7	<ul style="list-style-type: none"> <li>• Fuser Unit</li> <li>• Fuser Cleaner</li> </ul>	<p>Ensure the fuser unit is not damaged or dirty. Clean or replace, if necessary.</p> <p>Ensure the fuser guides and gears are not broken and are free of paper.</p> <p>Ensure the fuser cleaner is clean and not damaged, and replace, if necessary.</p> <p><b>Note:</b> The fuser unit and fuser cleaner are customer order supplies.</p>
8	<ul style="list-style-type: none"> <li>• Paper Exit Roller</li> <li>• Paper Exit Idler Roller</li> <li>• Gears</li> <li>• Paper Exit Frame Assembly</li> </ul>	<p>Check the paper exit unit for damage.</p> <p>Ensure the paper exit roller is not damaged.</p> <p>Ensure the paper exit gears and bearings are good.</p> <p>Ensure the paper guides are not bent or dirty.</p> <p>Clean or replace parts, if necessary.</p> <p>If any other parts are damaged, replace the paper exit frame assembly.</p>

## Lower Feed Unit Paper Feed Service Check

	FRU	Action
1	Remove Options	Ensure the printer works correctly, without the lower feed unit and duplex unit installed. Disconnect or remove.
2	Check for Recommended Paper	<p>Ensure the lower feed unit cassette is using a recommended paper.</p> <p>Ensure the paper does not contain excessive humidity.</p>
3	Lower Feed Paper Feed Cassette	<p>Ensure the paper cassette (Tray2) is not damaged and the paper stop is set to the proper position.</p> <p>Replace any damaged parts.</p>
4	<ul style="list-style-type: none"> <li>• Lower Feed Clutch (PKCL)</li> <li>• IOD1 P.W.B. Board</li> </ul>	<p>Ensure the paper feed clutch (PKCL) activates and turn the paper feed roller</p> <p>If the paper feed clutch fails to activate, ensure it is connected properly and the lower feed unit is properly installed.</p> <p>Replace the paper feed clutch if it still fails to activate.</p> <p>If the problem still exists, ensure connector DCN8, on the IOD1 P.W.B. board, is connected.</p> <p>Replace the IOD1 P.W.B. board, if necessary.</p>
5	Drive Gear Assembly	Check the drive gear assembly for damage and replace, if necessary.
6	<ul style="list-style-type: none"> <li>• Paper Feed Roller</li> <li>• Separation Pad</li> </ul>	Inspect the paper feed roller and the separation pad for wear or damage and replace, if necessary.

	FRU	Action
7	Lower Feed Rear Cover Assembly	<p>Check the lower feed transport roller, in the lower feed rear cover assembly, for dirt or damage and replace, if necessary.</p> <p><b>Note:</b> This is used for the optional duplex unit.</p>
8	Lower Feed Paper Guides	<p>Ensure the lower feed paper guides are clean and not damaged and replace, as necessary.</p>
9	<ul style="list-style-type: none"> <li>• Lower Feed Transport Roller Clutch (DP KCL)</li> <li>• IOD1 P.W.B. Board</li> </ul>	<p>If the duplex unit is attached, the lower feed transport clutch (DPKCL) is activated to recycle paper through the printer for duplexing.</p> <ul style="list-style-type: none"> <li>• Ensure the lower feed transport clutch is activated during duplex operations.</li> <li>• If the clutch does not activate, ensure its connectors are properly connected and replace, if necessary.</li> <li>• Ensure DCN8 on the IOD1 P.W.B. board is connected and replace the IOD1 P.W.B. board, if necessary.</li> </ul>

## Duplex Paper Feed Service Check

	FRU	Action
1	Check for Paper	<p>Ensure all paper is cleared from the printer and options.</p> <p><b>Note:</b> See the illustration, “<b>Lower Feed Unit Theory of Operation</b>” on page 1-48 and “” on page 1-50, for more information.</p> <p><b>Note:</b> The printer can be checked by running a test print without the duplex being selected or connected.</p> <p>If the paper jam is 231 and the paper is being fed into the printer and stopped, go to the “<b>Lower Feed Unit Paper Feed Service Check</b>” on page 2-79.</p>
2	Duplex Upper Solenoid (DSOL-U)	<p>Check the duplex top unit, upper solenoid assembly to ensure there are no binds or damaged parts.</p> <p>Replace any damaged parts, if necessary.</p>
3	Top Cover D Rolls	<p>Check the top cover assembly to ensure all the D rollers are in place and not damaged.</p> <p>Replace any damaged parts, if necessary.</p>
4	<ul style="list-style-type: none"> <li>• Top Cover (B) Assembly</li> <li>• Paper Guide RVS Assembly</li> <li>• Cover Low (B) Assembly</li> <li>• Paper Guide Bottom Assembly</li> <li>• Paper Guide Inner</li> </ul>	<p>Check the following part for dirt or damage, and replace if necessary.</p>

	FRU	Action
5	<ul style="list-style-type: none"><li>• Gears / Belts</li><li>• Duplex Lower Solenoid (DSOL-L)</li><li>• Bottom Gate</li></ul>	<p>Check the gears and belts in the duplex DPM1 and DPM2.</p> <p>Check the duplex lower solenoid (L) assembly for damage.</p> <p>Ensure the bottom gate, that directs paper into the printer, is not damaged.</p> <p>Replace any damaged parts, if necessary.</p>

## Print Quality Service Checks

### Background Service Check

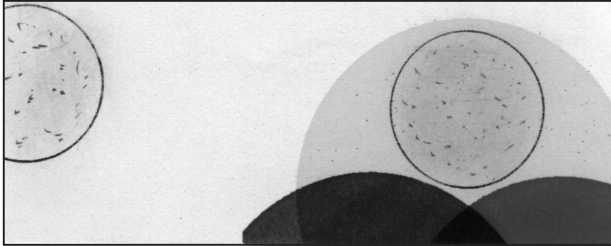

The Background is smeared due to the toner spread.

	<b>FRU</b>	<b>Action</b>
1	Toner Cartridge.	Too small charging amount in the development process.
2	Check Developer Bias Pole	Insufficient contact of the developer roller's bias pole.  Confirm whether the developer bias pole is deformed or not.
3	OPC Belt Cartridge.	Life or failure of the belt cartridge.
4	High Voltage Power Supply Unit (HVU).	Failure of the high voltage power supply unit (HVU).

## Back Stain Service Check

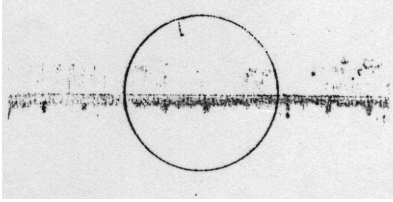

Backside of the paper is stained.

	FRU	Action
	Fuser Unit	<p>Fuser unit:</p> <ul style="list-style-type: none"> <li>• Cleaning pad is stained</li> <li>• Silicone oil is low</li> <li>• Fuser roller and back-up roller is stained.</li> </ul> <p>Replace the cleaning roller.</p> <p>Clean the fuser roller and back-up roller.</p> <p>Replace the fuser unit.</p> <p><b>Note:</b> The fuser unit is a customer order supply.</p>



## Banding Service Check

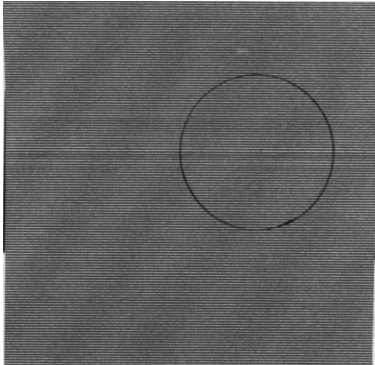

A banding line appears in the horizontal direction.

	<b>FRU</b>	<b>Action</b>
	OPC Belt Cartridge	Transfer failure due to uneven rotational speed caused by a shock which occurs when the seam of the OPC belt passes over the cleaning blade.

## Black Line Service Check

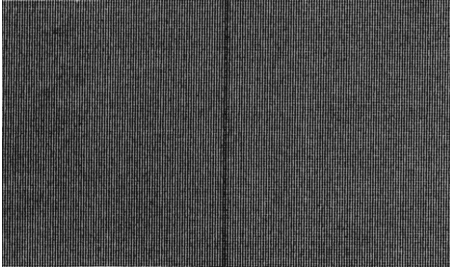

A fine black line appears in the printer image.

	FRU	Action
1	Charger Unit	Charge wire in the charger unit is contaminated.
2	OPC Belt Cartridge	OPC belt's surface is damaged.
3	OPC Belt Cartridge	Foreign particles (paper dust, and so on) are stuck in between the cleaning blade and the OPC belt.  Remove the OPC belt cartridge.  <ul style="list-style-type: none"> <li>• Clean the charger unit</li> <li>• Replace the OPC belt cartridge</li> </ul>
4	Check for Debris	Debris adhering to the base of the toner cartridge's developer roller is making contact with the OPC belt cartridge.

## Color Misregistration Service Check

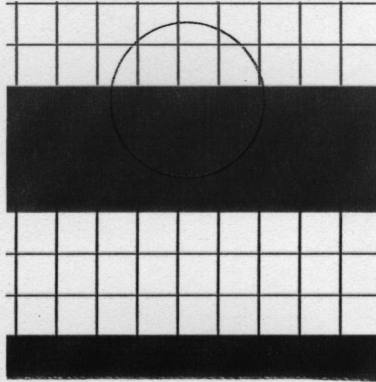

Color misregistration between two colors.

	FRU	Action
1	OPC Belt Cartridge	OPC belt cartridge is not properly installed.  Reset the OPC belt cartridge.
2	OPC Belt Cartridge	OPC belt cartridge is deformed.  Replace the OPC belt cartridge.
3	Cleaning Brush	Cleaning brush is unstable during operation.  Replace the cleaning brush.
4	Drum Cleaner Brush	OPC belt cartridge rotation load is excessive.  Replace the drum cleaner brush.

## Insufficient Fusing Service Check

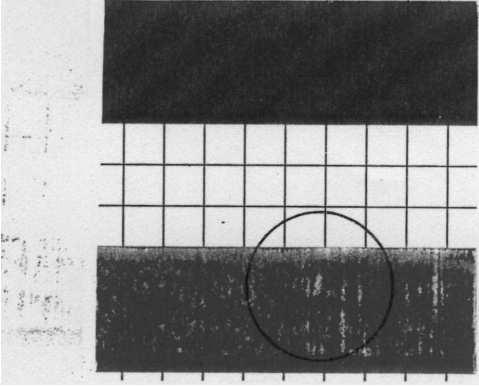

Printed image is partially missing.

	FRU	Action
1	Check Media Selection	Wrong selection of print media (label or envelope and so on) from the computer.  Adjust the mode of the computer side to suit the print media used.
2	Check for Recommended Paper	Recommended paper not used.  Use recommended paper.
3	Fuser Unit	Fuser Unit failure.  <b>Note:</b> The fuser unit is a customer order supply.

## Insufficient Gloss Service Check

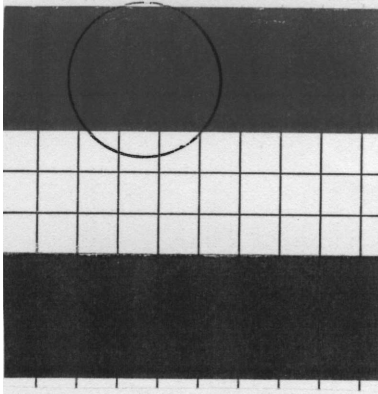

Gloss on the paper is not sufficient.

	<b>FRU</b>	<b>Action</b>
1	Cleaning Roller	Cleaning roller is stained. Replace the cleaning roller.
2	Fuser Unit	Fuser roller is deteriorated. Replace the fuser unit. <b>Note:</b> The fuser unit is a customer order supply.

## Jitter Service Check

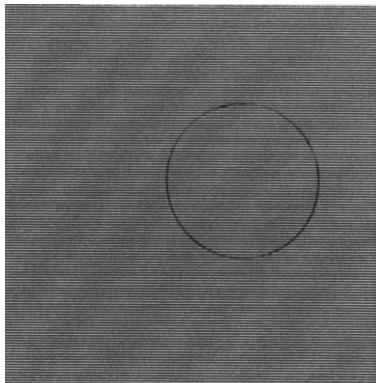

Uneven optical density appears periodically in the horizontal direction.

	<b>FRU</b>	<b>Action</b>
1	Main Gear Unit	Failure of main motor. <ul style="list-style-type: none"><li>• Irregular rotation of the drive motor</li><li>• Failure of the gear</li><li>• Variation of the OPC belt running speed (due to previous points)</li></ul>
2	Belt Cartridge	Failure of the OPC belt cartridge

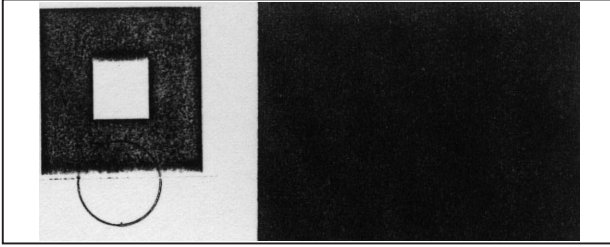
**Missing Image at Edge Service Check**

The image has missing or peeling toner at the edge.

	<b>FRU</b>	<b>Action</b>
1	Toner Cartridge	Too small a toner mass amount and charging amount in the development process.
2	OPC Belt Cartridge	The belt is deformed and wavy.

## Mixed Color Image Service Check

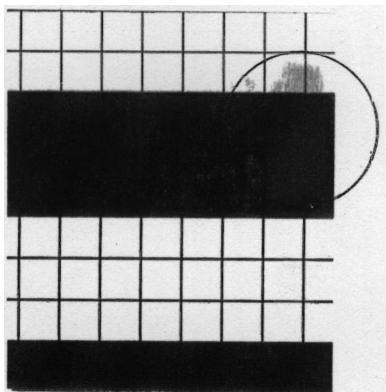

Mixed color image appears.

	FRU	Action
1	Toner Cartridge	<p>Toner cartridge failure.</p> <ul style="list-style-type: none"> <li>• Blade pressure on the developer roller is not correct.</li> <li>• Blade is deformed.</li> </ul> <p>Ensure toner cartridge installs smoothly.</p> <p>Replace the toner cartridge.</p>
2	Front Cover Unit	<p>Restitution error in the toner cartridge.</p> <p>Ensure the front cover unit is locked.</p>



## Mottle Service Check

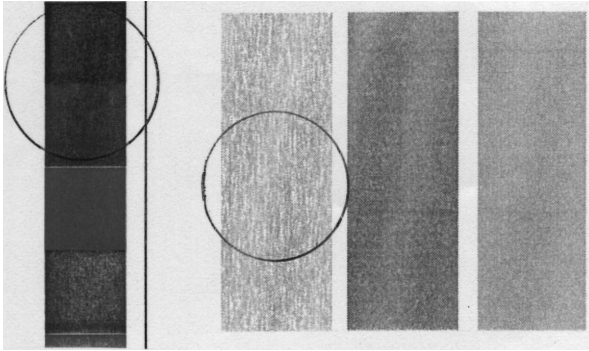

Variation of the optical density is found in the image.

	<b>FRU</b>	<b>Action</b>
1	Transfer Unit	Transfer unit is not in place.  Ensure the transfer unit is firmly locked in place.
2	Transfer Roller	Transfer roller assembly not correct.  Ensure the transfer roller is properly installed.
3	High Voltage Unit	THV output to the DC high voltage unit is not correct.  Replace the DC high voltage unit.
4	Toner Cartridge	Toner cartridge failure.  Replace the toner cartridge.
5	Check Paper	Paper in printer is deformed.  Replace paper.

## Residual Image Service Check

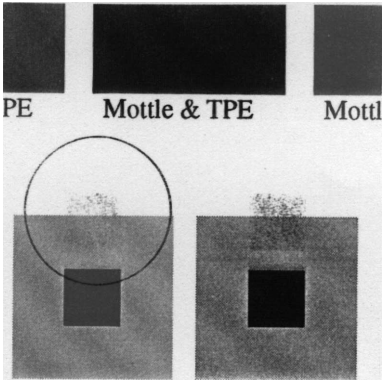
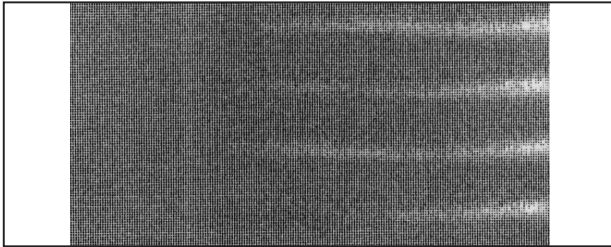

Image of the preceding page appears on every other page.

	<b>FRU</b>	<b>Action</b>
1	Cleaning Brush	Cleaning brush failure. Ensure proper installation of the drum cleaner.
2	Drum Cleaner	Drum cleaner bias pole contact failure. Clean or replace.
3	High Voltage Unit	DC high voltage unit failure. Replace the DC high voltage unit.

## Ribbing Service Check



Light print occurs in the right or left side of the image.

	<b>FRU</b>	<b>Action</b>
1	Check That Printer is Level	Table printer is sitting on is slightly tilted.  Tilt should be less than 1/2 inch.  Confirm the printer table is large enough and the printer is level.
2	Toner Cartridge	Insufficient amount of toner in the toner cartridge.  Shake the toner cartridge horizontally several times to level the toner.
3	Toner Cartridge	Toner in the toner cartridge is not level and collects on one side.
4	Toner Cartridge	The spring at the back of the developer unit is deformed.
5	Front Cover Unit	The front cover unit is not firmly closed.  Confirm the open/close motion on the front cover unit.

## Toner Drop Service Check

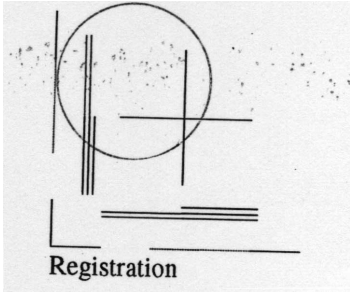

A toner spot stain on the paper is caused by the toner dropping within the printer engine.

	FRU	Action
1	Waste Toner Feeder	<p>Toner drops on the transfer drum due to a breakdown of the waste toner feeder drum cleaner.</p> <ul style="list-style-type: none"> <li>• The waste toner feeder mylar is deformed.</li> <li>• Waste toner is not properly collected by the waste toner feeder.</li> </ul> <p>Check the cleaning brush and waste toner feeder.</p> <ul style="list-style-type: none"> <li>• Clean the perimeter of the cleaning brush.</li> <li>• Check the seal for damage or deformation.</li> <li>• Check whether the waste toner is stuck in the printer engine. If so, absorb and vacuum.</li> </ul>
2	Toner Cartridge	<p>Toner adhering to the developer roller drops onto the OPC belt.</p> <p>Remove the toner cartridge, clean and replace if necessary.</p>

## Vertical Line Service Check

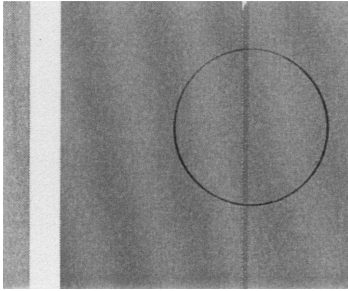

A vertical line appears in the printed image.

	<b>FRU</b>	<b>Action</b>
1	Transfer Drum	Foreign particles (dust and so on) adhere to the parts located around the transfer drum, and consequently contact the toner image on the transfer drum.
2	Discharger Unit	Clean the paper discharger unit.
3	Check D Guide and D Separator Pawl	Clean the D guide and D separator pawl.
4	Drum Cleaner	Remove the drum cleaner.  Clean inside and outside the waste toner feeder.

## Vertical Staggering Image Service Check

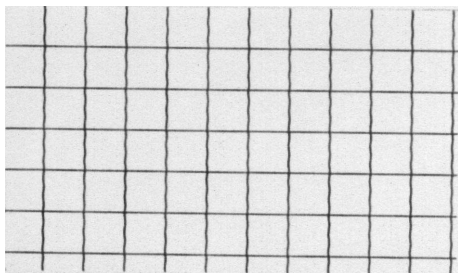

Printed image staggers in the vertical direction.

	<b>FRU</b>	<b>Action</b>
1	Check for Vibrations	Shock or vibrations to the printer.
2	Optical Unit (Printhead)	Optical unit failure caused by vibration from the scanner motor rotation.

## Vertical White Band Service Check

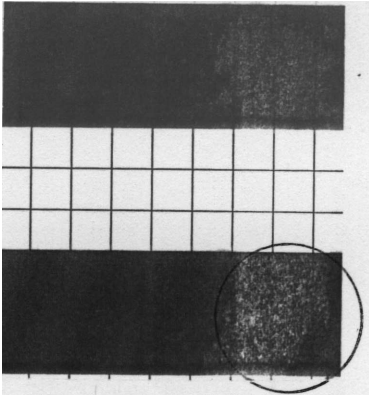

White band appears in the vertical direction of the printed image.

	FRU	Action
1	Transfer Drum	<p>Silicone oil adhering to the transfer drum.</p> <p>Wipe off the oil adhering to the transfer unit and its perimeter.</p> <p>Replace the transfer drum.</p>
2	Toner Cartridge Cleaning Brush	<p>If the oil adhesion is excessive, replace the belt cartridge, cleaning brush and toner cartridge.</p>

## White Band Service Check

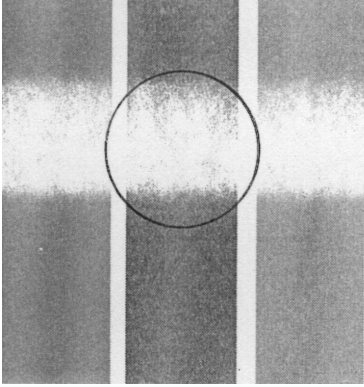

A white banding line appears, in the horizontal direction, causing a missing image.

	<b>FRU</b>	<b>Action</b>
1	Check Transfer Unit	Transfer unit installation failure and deformation of the transfer roller.  Ensure the transfer unit is properly installed and locked on both sides.
2	Transfer Roller	Contact failure on the transfer roller bias pole.  Ensure the transfer unit is properly installed.
3	TR Cam Clutch (TRCM)	TR cam clutch failure.
4	Transfer Unit	Replace the transfer unit.



## White Line I Service Check

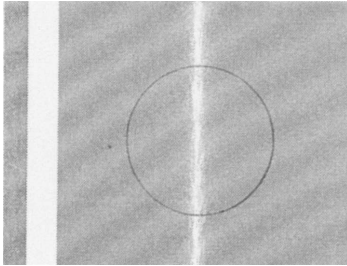

Vertical white line appears in a specific color area when test-printed in the four color mode (stripe mode).

	FRU	Action
1	Developer Roller - Toner Cartridge	<ul style="list-style-type: none"> <li>• Foreign particles adhere to developer roller in a specific color.</li> <li>• Run the test print.</li> <li>• Confirm the toner cartridge causing the white line.</li> <li>• Remove the foreign particles adhering to the developer roller.</li> </ul>
2	Toner Cartridge	Developer roller surface is damaged.

## White Line II Service Check

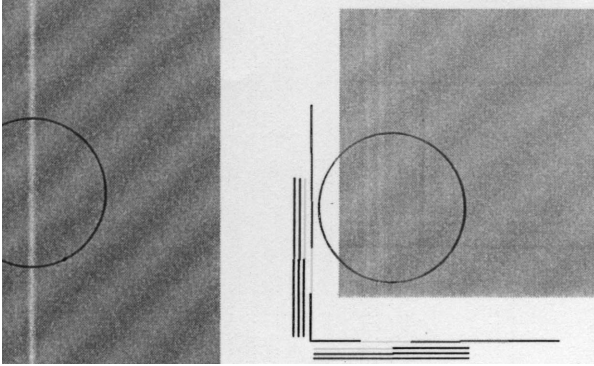

Vertical white line appears from the leading edge to the trailing edge of the printed image.

	FRU	Action
1	Optical Unit (Printhead)	<p>Clean the dust-proof glass.</p> <p>Dust-proof glass in the optical unit is smeared with toner or foreign particles.</p> <p>Remove the belt cartridge and toner cartridge.</p> <p>Remove the dust-proof glass from the optical unit.</p> <p>Clean the dust-proof glass.</p>
2	Optical Unit (Printhead)	<p>Foreign particles adhering to the laser beam opening of the optical unit.</p> <p>Clean the laser beam opening in the optical unit.</p>
3	Toner Cartridge	Foreign particles mixed in the toner cartridge.

## White Spot / Black Spot Service Check

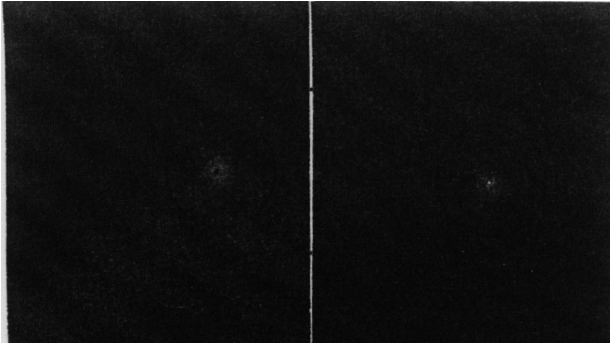

A white spot and black spot appears on the paper.

	FRU	Action
1	OPC Belt Cartridge	Foreign particles adhering to the OPC belt or transfer drum.  Remove the belt cartridge. <ul style="list-style-type: none"> <li>• Lightly wipe off the foreign particles using a cotton cloth.</li> <li>• Replace the belt cartridge.</li> </ul>
2	Transfer Drum	OPC belt or transfer drum damaged.  Open the transfer unit and check the transfer drum. <ul style="list-style-type: none"> <li>• Lightly wipe off the foreign particles adhering to the transfer drum using a cotton cloth.</li> <li>• Replace the damaged transfer drum.</li> </ul>
3	Toner Cartridge	Foreign particles mixed in the toner.  Remove the toner cartridge.
4	Transfer Unit	Foreign particles adhering to the transfer roller, or the transfer roller is deformed.  Replace the transfer unit.

## White Print Service Check

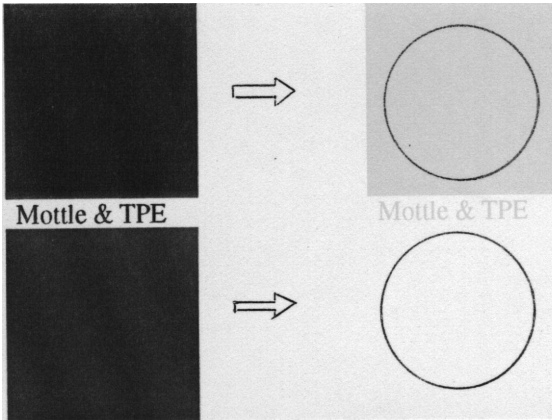

Blank page (no print) is output or missing a specific color.

	<b>FRU</b>	<b>Action</b>
1	Optical Unit (Printhead)	Laser light path is blocked by paper or other material stuck at the opening of the optical unit.  Ensure there are no foreign particles stuck at the opening of the optical unit.
2	Transfer Clutch (TRCM)	Transfer clutch is broken (not functioning).  Replace the transfer clutch.
3	OPC Belt Cartridge	No OPC belt bias voltage (CBV).  Replace the OPC belt cartridge.
4	High Voltage Unit	No output from the high voltage unit (HVU).  Replace the high voltage unit (HVU).

## Wrinkle / Image Migration Service Check

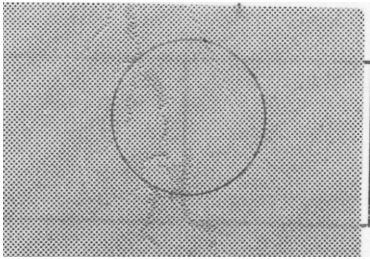

Banding shadows of different optical density appear due to the wrinkle, image migration and color misregistration occurring on the paper.

	<b>FRU</b>	<b>Action</b>
1	Check for Recommended Paper	Paper being used is not recommended for this printer.  Recommended paper or fresh pack of paper.
2	Paper Discharger Unit	Paper discharger unit in the transfer unit is not functioning. Ensure discharger unit is properly installed.
3	Transfer Unit	The transfer unit is not locked properly. Check that transfer unit is locked on both sides.
4	Fuser Unit	The fuser roller is deformed or has reached end of life. Ensure the fusing unit is installed properly and fixed with set screws.
5	Fuser Unit	One side of the fuser unit was lifted when installed.

## Spacing Table

### Roller Specifications

Name of Roller	Note: Out Diameter (Approx.) mm	Number of Rotation rpm	Remarks
Paper Feeding Roller	ø 40	123	74mm pitch
Registration Roller	ø 14	212	34mm pitch
Transfer Roller	ø 20	145	63mm pitch
Developing Roller OPC Belt Cartridge	ø 18	225	41mm pitch
Transfer Drum	ø 121	24	380mm pitch
OPC Belt OPC Belt Cartridge	1 = 380	24	
Fuser Roller Fuser	ø 50	55	165mm pitch
Backup Roller Fuser	ø 50	55	165mm pitch
Paper Exit Roller	ø 15	184	50mm pitch

---

## 3. Diagnostic Aids

This chapter explains the tests and procedures to identify printer failures and to verify repairs have corrected the problem.

The following diagnostic aids can be initiated at POR by pressing certain button sequences. These tests are also available in diagnostic mode. See “**Diagnostic Mode**” on page 3-5, for more information.

---

### Disabling Download Emulations

Error Code 964: Download Emulation CRC Failure. Checksum failure detected in the emulation header or emulation file.

Error Code 965: Download Emulation Outdated. Time stamps indicate the download emulation and RIP code are incompatible.

To help resolve Download Emulation problems, the following steps are necessary to instruct the printer to POR without activating any download emulations.

To disable the download emulation:

1. Turn the printer Off.
2. Press and hold the **Go** and **Menu** buttons.
3. Turn the printer On and release the buttons once “Performing Self Test” displays.

After POR completes, the **CONFIG Menu** is displayed.

4. Select **Download Emuls** from the menu.
5. Select the **Disable Option**.

The printer automatically exits the configuration menu and initializes as if the download emulator were not installed. Once the printer is idle, a new emulator can be downloaded again.

6. Program the download emulation into the code overlay SIMM.
7. If these steps do not resolve the problem, replace the code overlay SIMM and re-download the emulation.

# Paper Jam Sequence

Go to the **“Paper Jam Messages”** on page 2-27, for more information.

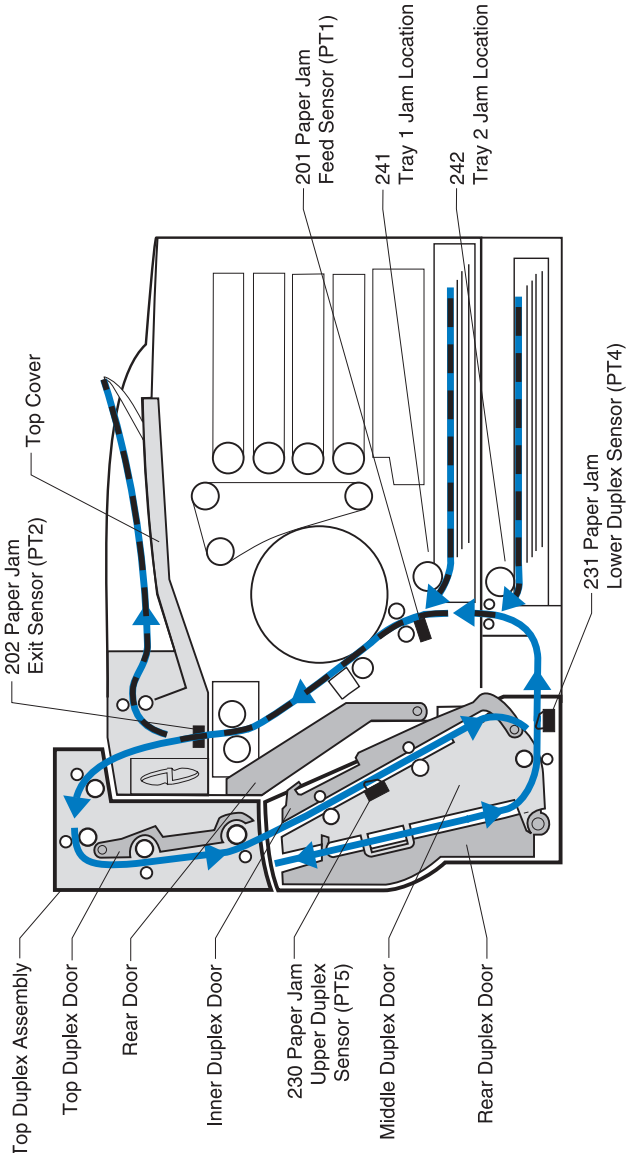



**Paper Jam 201** - Indicates media is jammed between the paper registration sensor and the paper exit sensor.

- Open the rear cover to access the area of the paper jam. Notice the location of the paper jam.
- Determine if media jammed prior to activating the paper feed sensor in the printer. The paper feed sensor may not be detecting media over the sensor, or media may be arriving late.
- Go to **“201 Paper Jam” on page 2-28.**

**Paper Jam 202** - (POR complete) Indicates media is jammed at the exit sensor.

- Open the top cover to access the area of the paper jam.
- Be sure the coating roll is installed, not contaminated and operating correctly. Replace if necessary. Check for pieces of paper or other debris in or around the paper exit sensor area of the fuser.
- Check the paper exit roller, pinch roller 2 and the pinch roller springs for signs of damage, contamination or broken parts.
- If media is jamming at, or over the paper exit sensor, a problem may exist with the paper exit flag or spring. Go to **“202 Paper Jam” on page 2-29.**

**Paper Jam 202 Duplex Installed** - Go to **“Duplex Paper Feed Service Check” on page 2-81.**

### Paper Jam 23X

- 230 Duplex - Indicates that media is jammed at the top of the duplex unit. Open the top duplex door to access the jam.  
If the media is jamming at or over the duplex upper paper sensor, go to **“230 Paper Jam” on page 2-30.**
- 231 Duplex - Indicates media is jammed at the lower part of the duplex unit. Open the duplex lower door to access the jam.  
If the media is jamming at or over the duplex lower paper sensor, go to **“231 Paper Jam” on page 2-31.**

Paper Jam 24X - Indicates media is jammed in or around the paper tray X (X= tray 1 or 2). Open tray x to remove the jam.

- 241 go to **“Paper Feed Service Checks” on page 2-77.**
- 242 go to **“Lower Feed Unit Paper Feed Service Check” on page 2-79.**

---

## Diagnostic Mode

To enter the diagnostic mode:

1. Turn the printer Off.
2. Press and hold the **Go** and **Return** buttons.
3. Turn the printer On.
4. Release the buttons when "Performing Self Test" displays on the operator panel.

The tests display on the operator panel in the order shown:

- Print registration
  - Setting Tray 2 left margin
  - Setting top margin
- Print tests
  - Tray 1
  - Tray 2 (displayed only if Tray 2 is installed)
  - Print quality pages
- Hardware tests
  - LCD test (operator panel)
  - Button test (operator panel)
  - Check engine NVRAM
  - ROM memory test
  - Parallel wrap test
  - Parallel 1, 2, or 3 wrap test (displayed only if a parallel port is available via PC1 in slot 1, 2 or 3)
  - Serial wrap test (displayed only if the printer supports a standard serial port)
  - Serial 1, 2 or 3 wrap test (displayed only if a serial port is available using PC1 slot 1, 2 or 3)
- Duplex tests (displayed only if installed)
  - Duplex left margin
- Device tests (displayed only if the flash or disk options are installed)
  - Quick disk test
  - Disk test/clean
  - Flash test

- Printer setup
  - Setting the page count
  - Viewing the permanent page count
  - Setting configuration ID
- Reset counters
  - Reset transfer drum
  - Reset maintenance kit
  - Reset fuser
  - Reset fuser cleaner
  - Reset photo dev cart
- Error log
  - Viewing and clearing the error log
- Exit diagnostics

### Diagnostics Menu Structure

When the diagnostic menu is entered, each diagnostic main menu item displays on the operator panel. When a diagnostic test is selected from the main menu, a sub menu displays and each individual test displays in the order shown. Any options that are referred to in the menus are displayed when the option is installed.

### Print Quality Test Pages

To run the print quality test pages:

1. Turn the printer Off.
2. Press and hold **Select** and **Return**, while turning On the printer.
3. Release the buttons once “Performing the Self Test” displays.

After POR completes, the **CONFIG Menu** displays.

4. Select **Prt Quality Pgs** from the menu; one copy of the test page prints.
5. The test pages print one time.

**Note:**

- To print additional pages, repeat the last step.
- See **“Print Quality Test Page” on page 3-22**, for an example of the test pages.

---

## Print Registration

Print registration provides a method for checking and setting the print position on the page.

Upon first entering the registration menu, your selections are Tray 2 left margin or top margin.

**Note:** Tray 1 left margin is set by the manufacturer and cannot be changed.

### Setting Tray 2 Left Margin

1. Select **Registration**.
2. Select **Tray 2 Left Margin**.
3. Adjust Tray 2 left margin by increasing the value displayed using **Menu>** or **Menu<**.

The range is 1 to 15.

4. To save the value press **Select**.

Two alignment pages automatically print for the change made. A correct adjustment is determined when the pages are held to the light and the lines on both pages line up with each other.

5. Press **Return** to exit the registration menu.

### Setting Top Margin

1. Select **Registration**.
2. Select **Top Margin**.
3. Adjust the top margin by increasing the value displayed using **Menu>** or **Menu<**.

The range is 1 to 15.

4. To save the value press **Select**.

A quick test page automatically prints for the change made.

5. Press **Return** to exit the registration menu.

---

## Print Tests

The purpose of the diagnostic print tests is to verify that the printer can print on media from each of the installed input options.

For each input source selected, the following choices are available:

Single (prints the print test page once).

Continuous (continue printing the print test page until Return or Stop is pressed).

- Tray 1 = single, Tray 1 = continuous
- Tray 2 = single, Tray 2 = continuous (if installed)

The contents of the print test page vary depending on the media installed in the selected input source. If a source is selected that contains paper, legal, letter and so on, a page similar to the quick test page is printed. However, the page does not contain the print registration diamonds.

If Continuous is selected, all sources printing print the same page continuously until the test is stopped. If continuous is selected for a source containing envelopes, the envelope print test pattern prints on the first envelope and subsequent envelopes are blank.

**Note:** The print test page may be printed on any paper size, however more than one sheet of some media sizes may be required. The print test page is always single sided, regardless of duplex settings or the presence of the duplex unit.

To run the print test page:

1. Select **Print Tests** from the diagnostic menu.
2. Select the media source.
3. Select **Single** or **Continuous**.

## 5024-001

If single is selected, no buttons are active during printing. If continuous is selected, return or stop can be selected to cancel the test.

**Note:** The power indicator blinks while the page is printing. Check each test page from each source to assist in print quality and paper feed problems.

---

## Hardware Tests

The following hardware tests can be selected from this menu:

LCD Test	Button Test
DRAM Memory Test	ROM Memory Test
Parallel Wrap (if available)	Serial Wrap (if available)
Serial 1 Wrap (if available)	Serial 2 Wrap (if available)
Serial 3 Wrap (if available)	

### LCD Test

To run the LCD test:

1. Select **LCD Test** from the diagnostic menu.  
The LCD test continually executes the LCD display test.
2. Press **Return/Stop** to cancel the test.

### Button Test

To run the button test:

1. Select **Button Test** from the diagnostic menu.  
With no buttons pressed, several OP (Open) appear on the display.
2. Press each button one at a time and a CL (Closed) displays in place of an OP.  
The proper operation of each button can be checked.
3. Press **Return/Stop** to cancel the test.

## Parallel Wrap Test

This test is used with a wrap plug to check operation of the parallel port hardware. Each parallel signal is tested.

To run the parallel wrap test:

1. Disconnect the parallel interface cable and install the wrap plug (P/N 1319128).
2. Select the **Parallel Wrap Test** from the menu.

The power indicator blinks indicating the test is in progress. The test runs continuously until canceled.

When the test finishes, the screen updates. If the test passes, the pass count increases by 1, however if the test fails, one of the following messages display for approximately 3 seconds:

Sync Busy Error	Interrupt Request Error
Strobe Interrupt Request Error	Init Fail Error
Init Busy Error	Init Rise Error
Host Busy Error	RAM Data FF Error
RAM Data AA Error	RAM Data 00 Error
RAM Data 55 Error	DMA Count Error
DMA Address Error	DMA Interrupt Error
DMA Memory Error	DMA Background Error
Clear Init Rise Error	False Init Rise Error
Autofeed Rising Interrupt Error	Clear Autofeed Rise Error
False Autofeed Rise Error	Autofeed Falling Interrupt Error
Clear Autofeed Fall Error	

Once the maximum count is reached the test stops. The power indicator goes On solid and the final results display.

3. Press **Return/Stop** to exit the test.

## ROM Memory Test

The ROM memory test is used to check the validity of the system board code and fonts.



To run the ROM memory test:

1. Select **ROM Memory Test** from the menu.

P and F represent the same numbers for DRAM. The power indicator blinks indicating the test is in process. The test runs continuously.

2. Press **Return/Stop** to exit the test.

Each time the test finishes, the screen updates with the result. If the test passes, the pass count increases by 1, however if the test fails, one of the following messages displays for approximately 3 seconds:

- ROM checksum error
- ROM burst read error

Once the maximum pass count or fail count is reached, the test stops with the power indicator On solid. The final results display on the screen.

## DRAM Memory Test

The purpose of this test is to check the validity of SDRAM, both standard and optional. The test writes patterns of data to SDRAM to verify that each bit in memory can be set and read correctly.

To run the SDRAM memory test:

1. Select **SDRAM Memory Test** from the menu.

The power indicator blinks indicating the test is in progress.

2. Press **Return/Stop** to exit the test.

P:##### represents the number of times the memory test has passed and finished successfully. Initially 000000 displays with the maximum pass count being 999,999.

F:##### represents the time the memory test has failed and finished with errors. Initially 00000 displays with the maximum fail count being 99,999.

Once the maximum pass count or fail count is reached, the test is stopped, the power indicator is turned On solid, and the final results display. If the test fails, the message DRAM error, displays for approximately three seconds and the fail count increases by 1.

## Serial Wrap Test

This test is used to check the operation of the serial port hardware using a wrap plug. Each signal is tested.

To run the serial wrap test:

1. Disconnect the serial interface cable and install the wrap plug.
2. Select the appropriate **Serial Wrap Test** from the menu.

The following screen displays: serial X wrap P:##### F:#####

- X indicates which serial port is being tested,
  - black = standard
  - 1 = optional serial port #1
  - 2 = optional serial port #2
  - 3 = operational serial port #3.
- F represents the number of times the test has failed or finished with errors. Initially 00000 is displayed for #####. The maximum fail count is 99,999.

**Note:** The power indicator blinks indicating the test is running.

Each time the test finishes, the screen updates with the result. If the test passes, the pass count increases by 1, however if the test fails, one of the following failure messages displays for approximately 3 seconds and the fail count increases by 1:

Receive Status Interrupt	Error Status Error
Receive Data Interrupt Error	Transmit Data Interrupt Error
Transmit Empty Error	Threshold Error
Receive Data Ready Error	Break Interrupt Error
Framing Error	Parity Error
Overrun Error	Data Error
Data 232 Error	Data 422 Error
FIFO Error	DSR Error
DSR PIO Error	DSR Interrupt Error
CTS Error CTS PIO Error	CTS Interrupt Error

Once the maximum count is reached the test stops and the final results display.

3. Press **Return/Stop** to exit the test.

---

## Duplex Tests

### Duplex Left Margin

The left margin adjust lets the user set the left margin for the duplex option so it matches the base machine left margin, for alignment purposes. It can also be used to print a page for duplex testing.

To set the duplex left margin:

1. Enter diagnostic mode. See “**Diagnostic Mode**” on page 3-5, for more information.
2. Select **Duplex Test**.
3. Select **Duplex Left Margin**.
4. Adjust left margin position using **Menu>** or **Menu<**.
5. To save the value press **Select**.

The range is 1 to 15.

An alignment page automatically prints for the change made. A correct adjustment is determined when the page is held to the light and the lines on both sides of the page line up with each other.

6. Press **Return** to exit the diagnostic mode.

**Note:** The duplex feed test can be run using any of the paper sizes supported.

Pressing **Select** causes the alignment pages for the duplex unit to print. Once the pages have printed, the user needs to hold up the two sheets as designated by the headings on the page “Top of Sheet” to show the proper orientation of the page. Hold the pages to the light and set the left margin to the value whose vertical lines most closely align on the sheet. The printing alignment page status message displays and the power indicator blinks, while the pages are being fed through the printer. The duplex left margin cannot be canceled.

---

## Device Tests

### Quick Disk Test

This test performs a non-destructive read/write on one block per track on the disk. The test reads one block on each track, saves the data, and proceeds to write and read four test patterns to the bytes in the block. If the block is good, the saved data is written back to the disk.

To run the quick disk test:

1. Select the **Quick Disk Test** from the device tests menu.  
The power indicator blinks while the test is in progress.
2. The "Quick Disk Test/Test Passed" message displays and the power indicator turns On solid.
3. The "Quick Disk Test/Test Failed" message displays and the power indicator turns On solid.
4. Press **Go**, **Return**, or **Stop** to return to the device test menu.

### Disk Test/Clean

**WARNING:** This test destroys all data on the disk and should not be attempted on a good disk. Also note that this test may run approximately 1 1/2 hours depending on the disk size.

To run the disk test/clean test:

1. Select **Disk Test/Clean** from the device tests menu.  
"Files will be lost/Go or Stop?" message displays to warn the user that all contents on the disk will be lost.  
  
To exit the test immediately and return to the device tests menu, press **Return/Stop**. To continue with the test, press **Go**. If go is selected, "Disk Test/Clean/BAD:000000 00%" message displays. The screen updates periodically indicating the percentage of test completed and the number of bad blocks found.  
  
The power indicator blinks during the test. The test can be canceled anytime during the test by pressing **Return/Stop**.

Once the test is complete, the power indicator turns On solid and a message displays.

- “xxxx Bad Blocks/yyyyy Usable” message displays if fewer than 2000 bad blocks are detected. xxxx indicates the number of bad blocks and yyyyyy indicates the number of usable blocks.
  - “xxxx Bad Blocks/Replace Disk” message displays if more than 2000 bad blocks are detected. The disk cannot be recovered because too many bad blocks exist on the disk.
2. Press **Go** or **Return/Stop** to return to the device tests menu.

## Flash Test

This test causes the file system to write and read data on the flash to test the flash.

**WARNING:** This test destroys all data on the flash because the flash is reformatted at the end of the test.

To run the flash test:

1. Select **Flash Test** from the device tests menu.
  - The power indicator blinks while the test is running.
  - “Flash Test/Test Passed” message displays if the test passes and the power indicator turns On solid.
  - “Flash Test/Test Failed” message displays if the test fails and the power indicator turns On solid.
2. Press **Go** or **Return/Stop** to return to the device tests menu.

---

## Printer Setup

**Note:** Defaults within this printer can be set to either U.S. or Non-U.S.

### Setting the Page Count

This lets the servicer change the page count from the diagnostic menu. This is used whenever the engine board is replaced because this board contains the printer NVRAM memory where the page count is stored.

To set the page count:

1. Select **Page Count** from the diagnostic menu. To enter diagnostic mode, see “**Diagnostic Mode**” on page 3-5.

The current page count displays and the leftmost digit blinks, indicating it is the first digit to be changed.

2. Press either **Menu>** or **<Menu** until the value you want appears.
3. Press **Select** to move to the next digit.
4. Press **Menu>** or **<Menu** until the value you want appears.

Continue with each digit until you set the page count. You can skip any digit by pressing **Select**.

5. Press **Select** to save the new page count in NVRAM.
6. Press **Return/Stop** to exit the diagnostic menu.

### Viewing the Permanent Page Count

**Note:** The permanent page count can only be viewed; it cannot be changed.

To view the permanent page count:

1. Select **Permanent Page Count** from the menu.
2. Press **Return/Stop** to exit the diagnostic menu.

### Serial Number

The serial number is set at the factory and cannot be changed. This is for viewing the serial number only.

## 5024-001

The serial number will be XXXXXXXX (8 digit string)  
Where X=A to Z, or 0 to 9.

If you replace the main engine (MCTL P.W.B.) Board, the serial number needs to be identified from the serial number label on the printer.

## Setting Configuration ID

The configuration ID is used to communicate information about certain areas of the printer that cannot be determined using hardware sensors. The configuration ID is originally set at the factory when the printer is manufactured, however it requires resetting whenever you replace the controller board and can be set on the operator panel. However, the configuration ID is the only diagnostic function displayed until a valid ID is entered.

CONFIG IDs to be used for the 5024-001 printer:

- 000000 ID set when the operator panel is to support 850 + Katakana and not allow the power saver to be reset.
- 100001 ID set when the operator panel is to support 850 + Katakana and allow the power saver to be reset.
- 000088 ID set when the operator panel is to support 850 + NLS and not allow the power saver to be reset.
- 100089 ID set when the operator panel is to support 850 + NLS and allow the power saver to be reset.

To set the configuration ID:

1. Enter diagnostics mode, see **“Diagnostic Mode” on page 3-5**.
2. Select **Configuration ID** from the printer setup menu.

The current ID displays on the screen. The display should show one of the IDs from the above list. The leftmost digit blinks indicating that it is the first digit to be changed.

3. Press either **Menu>** or **<Menu** to change to the value you want appears.
4. Press **Select** to move to the next digit, or press **Select** again to skip a digit.

Change each digit as required.

5. When the last digit is changed, press **Select** to validate the Configuration ID.
  - If the ID is invalid then "INVALID ID" message displays on Line 2 before the ID re-displays. You have to reenter the configuration ID until a valid ID is verified.
  - If the ID is valid then the ID is saved in NVRAM and the printer automatically PORs to activate the new setting.

**Note:** When the printer PORs it does so in the normal mode.

## Parallel Strobe Adjustment

This setting lets the user adjust the factory setting for the amount of time strobe is sampled. This determines whether valid data is available on the parallel port.

Increasing this value means that strobe is sampled 50ns longer. Decreasing this value means that strobe is sampled 50ns shorter.

The range of this setting is -4 to +6.

Example of setting:

- A value of 0 indicates no adjustment is sampled from the factory setting.
- A value of -1 indicates the sample strobe time is reduced by 50ns.
- A value of +3 indicates the sampled strobe time is increased by 150ns.



---

## Resetting Counters

Resetting maintenance and supply counters are required after replacing the following parts during service.

- Transfer drum
- Maintenance kit
- Fuser
- Fuser cleaner
- Photo developer cartridge

Any other supplies can be reset in the operator supplies menu.

To reset an individual counter:

1. Select reset counters from the diagnostic mode menu.
2. Select the counter to be reset from the menu.

A message, with the individual counter on the first line, is displayed.

The second line displays (=Reset).

3. Press **Select**.

A message is displayed stating that the individual counter has been reset.

The next counter is displayed with the resetting of an individual counter.

---

## Error Log

### Viewing the Error Log

The error log provides a history of printer errors. The error log contains the 12 most recent errors that have occurred on the printer. The most recent error displays in position 1 and the oldest error displays in position 12 (if 12 errors have occurred). If an error occurs after the log is full, the oldest error is discarded. Identical errors in consecutive positions in the log are entered. All 2xx and 9xx error messages are stored in the error log.

To view the error log:

1. Select **Display Log** from the error log menu.

The error log displays on three screens as only four entries display at a time.

2. To move to the next screen press **Menu>** to move forward or **<Menu** to move backward.
3. Press **Return/Stop** to exit the error log.

## Clearing the Error Log

To clear the error log:

1. Select **Clear Log** from the error log menu.
2. Select **YES** to clear the error log or **NO** to exit the clear log menu.

If **YES** is selected, the empty error Log displays on the screen.

3. Press **Return/Stop** to exit the clear log menu.

## Restore EP Factory Defaults

To restore each of the printer settings contained in the EP setup menu to their factory default value select **Restore** from the menu. To exit the menu without restoring the settings to the factory default values, select **Do Not Restore**. Sometimes this is used to help correct print quality problems.

---

## Exiting Diagnostic Mode

Select **Exit Diagnostics** to exit the diagnostics mode and return to normal mode.

---

**Print Quality Test Page**

---

**Print Quality Test Page**

**5024-001**

---

## 4. Repair Information

---

### Removal and Cleaning Precautions

---

Observe the following precautions whenever you service the printer:

- Be sure to unplug the printer from the outlet before attempting to service the printer.
- To reassemble the printer, reverse the order of removal unless otherwise specified.
- Do not operate the printer anytime during removals. If it is absolutely necessary to run the printer with its covers removed, use care not to allow your clothing to be caught in revolving parts such as the gears, rollers and fan motor.
- Never touch the terminals of electrical parts or high-voltage parts such as the high voltage unit.
- Remove the ground wire when removing or replace the DC power supply. After installation is complete, confirm the ground wire is reconnected to the earth mark .
- After part replacement, ensure the wiring harness is not caught or damaged.
- Do not attempt to cut or extend the wiring harness.
- Confirm the wiring harness connector is connected properly.
- Be sure to handle the fuser carefully as it remains hot for a while after the printer stops running. Always unplug connectors by holding the connector housing.
- Be sure to use the fuse listed in the parts catalog.
- Remember to install the ground wire or ground plate to ensure positive conduction. Install the screw with a toothed washer in the correct position at reassembly.

---

## Handling the Printed Circuit Boards with MOS ICs

The following precautions must be observed when handling circuit boards with MOS (Metal Oxide Semiconductor) ICs.

### During Transportation/Storage:

- Do not remove new circuit boards from their protective conductive bags until needed.
- Do not store or place circuit boards in a location exposed to direct sunlight.
- When it becomes necessary to remove a board from its conductive bag or case, always place it on its conductive mat in an area as free as possible from static electricity.
- Do not touch pins of the ICs with your bare hands.

### During Replacement:

- Before you unplug connectors from the circuit boards, be sure the power cord has been unplugged from the power outlet.
- When you remove a board from its conductive bag or case, do not touch the pins of the ICs or the printed pattern. Place it in position by holding only the edges of the board.
- Before you plug connectors into the board, be sure the power cord has been unplugged from the power outlet.

### During Inspection:

- Avoid checking any IC directly with a multi-meter; use connectors on the board.
- Never create a closed circuit across IC pins with a metal tool.
- If it is necessary to touch the ICs and other electrical components on the board, be sure to ground your body.



---

## Image Belt Cartridge/OPC

The following precautions must be observed when handling the image belt cartridge/OPC:

### During Transportation/Storage

Use the specified carton whenever moving or storing the image cartridge/OPC.

### Handling

- The PC drum in the image belt cartridge/OPC exhibits the greatest light fatigue after being exposed to strong light over an extended period of time. Never expose it to direct sunlight. Cover the image belt cartridge/OPC when you remove it from the printer.
- Use care not to contaminate the surface of the PC drum with oil-base solvent, fingerprints, and other foreign matter.
- Do not scratch the surface of the PC drum.

### Parts Not To Be Touched

Any part where the mounting screws are used to meet a machine alignment set at the factory must not be removed, disassembled, or adjusted. For example, the paper pickup roll mounting bracket or internal parts not provided as replacement parts.

---

## Adjustments

The following service adjustments are required for this printer.

- Tray 2 left margin— See **“Setting Tray 2 Left Margin” on page 3-7**, for more information.
- Top margin— See **“Setting Top Margin” on page 3-7**, for more information.
- Duplex left margin— See **“Duplex Left Margin” on page 3-13**, for more information.

---

## Printer Removal Procedures

### Precautions to Take Before Maintenance Work

Do not implement any operation, removal, or modification and so on, which are not presented in this manual.

1. Turn the printer power Off and unplug the power cable from the outlet prior to starting removals or checks.
2. Prior to starting any repairs, read and understand the warnings in this manual.
  - High temperature
  - High voltage
  - Laser radiation
3. Collect and properly dispose of the waste toner or toner cartridge.
4. Remove the ground wire when removing or replacing the DC power supply.

After installation is complete, confirm the ground wire is reconnected to the earth mark .
5. Confirm the direction of all parts and screw length during removal/replacement.
6. Utilize the proper cleaning procedures/solvents during maintenance.
7. Confirm that all parts and covers are properly installed and assembled prior to starting the print test.

# Printer Covers

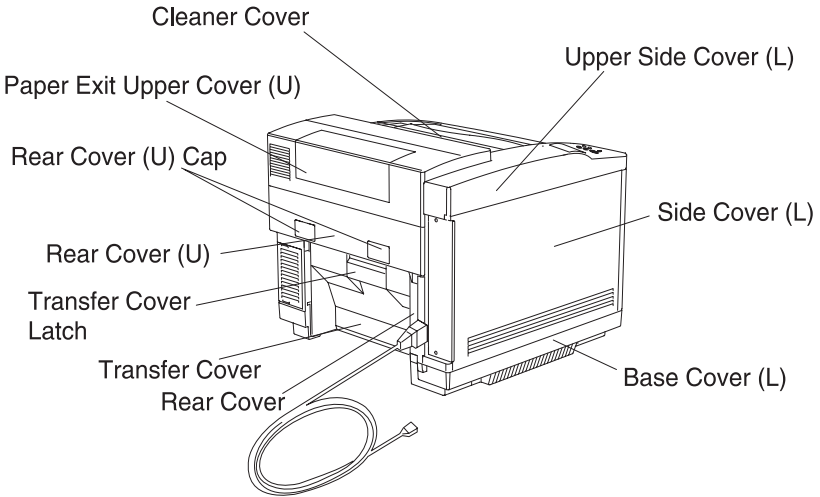
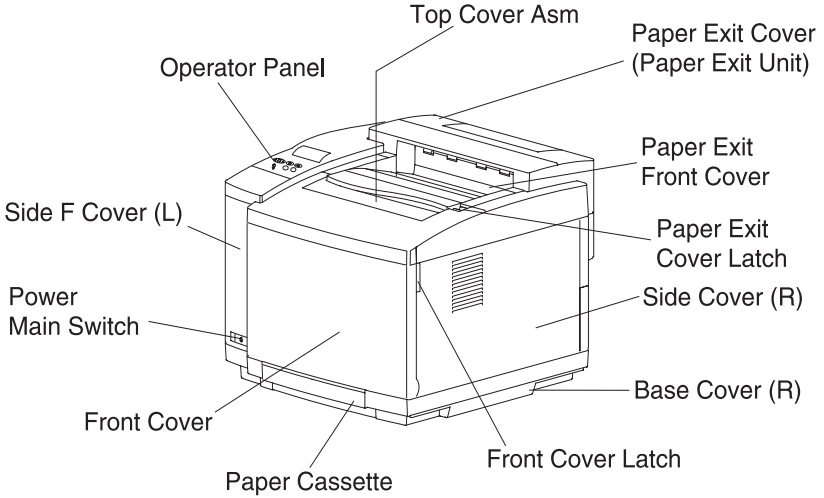

## Upper Side Cover (L) Removal

1. Push the paper exit cover release latch to open the paper exit unit.
2. Remove the screw BT4X10 (1) of the upper side cover (L).
3. Press the top exterior of the side cover (L) to unlock the 3 interlocks on the upper side cover (L).

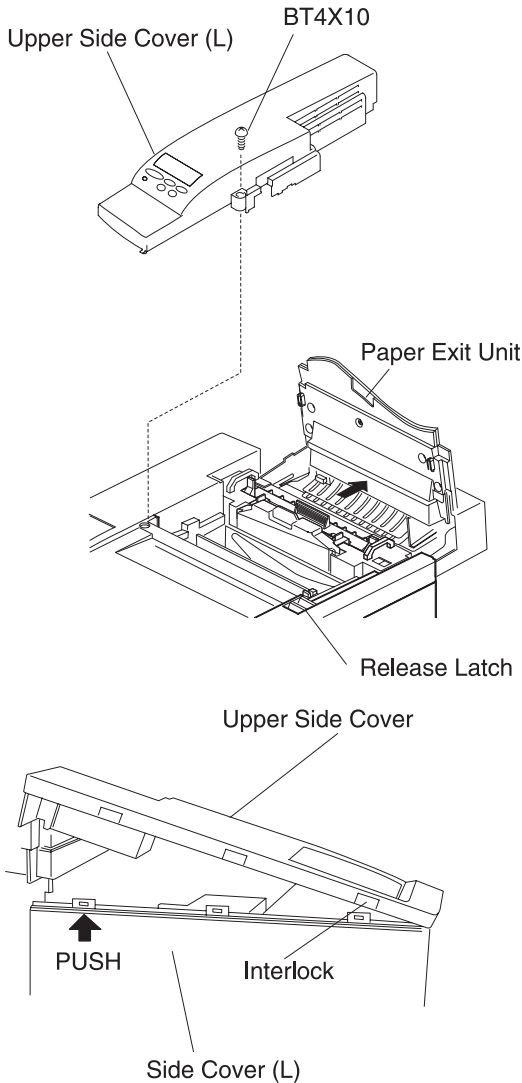

## Side Cover (R) Removal

1. Pull out the front cover latch to release and open the front cover unit.
2. Open the paper exit unit.
3. Remove the screw BT4X10 (1) at the rear of the right side cover.
4. Remove the screw BT4X10 (1) at the right side of the top cover assembly.
5. With the paper exit unit open, lift the back right corner of the top cover assembly.
6. Slide the side cover (R) toward the rear of the printer and remove the cover.

## 5024-001

7. To remove the ozone filter cover, slide the ozone filter cover away from the side cover (R). This may be done before or after removing the side cover (R) from the printer.

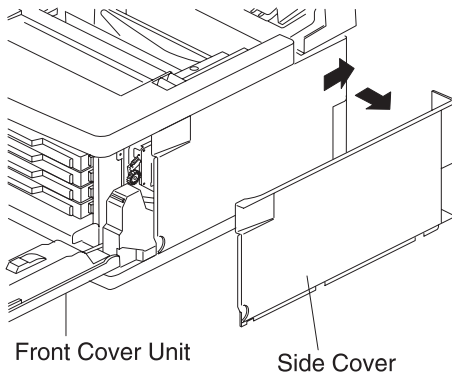
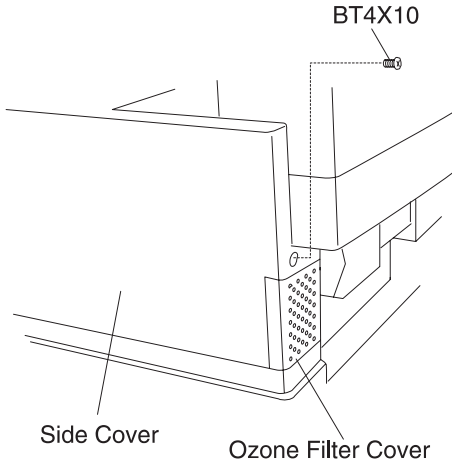

## Side Cover (L) Removal

1. Open the paper exit unit. See **“Printer Covers”** on page 4-6, for more information.
2. Remove the upper side cover (L). See **“Upper Side Cover (L) Removal”** on page 4-7, for more information.
3. Loosen the screws BT4X10 (2).
4. Slowly pull up on the corners of the side cover (L) to remove.

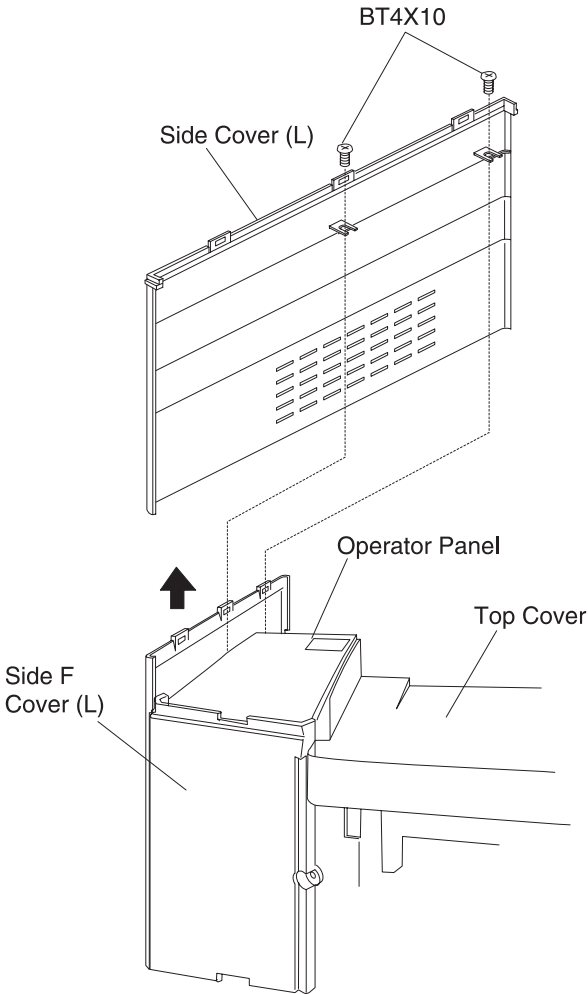



## Side F Cover (L) Removal

1. Open the paper exit unit and front cover. See **“Printer Covers” on page 4-6**, for more information.
2. Remove the upper side cover (L). See **“Upper Side Cover (L) Removal” on page 4-7**, for more information.
3. Remove the side cover (L). See **“Side Cover (L) Removal” on page 4-10**, for more information.
4. Remove the screw BT4X10 (1) from the side F cover (L).
5. Slightly lift up the front left part of the top cover.
6. Pull up the side F cover (L) and remove the hook, on the backside of side F cover (L), from the frame.
7. Remove the side F cover (L).
8. Remove the switch support and remote switch assembly from the side F cover.

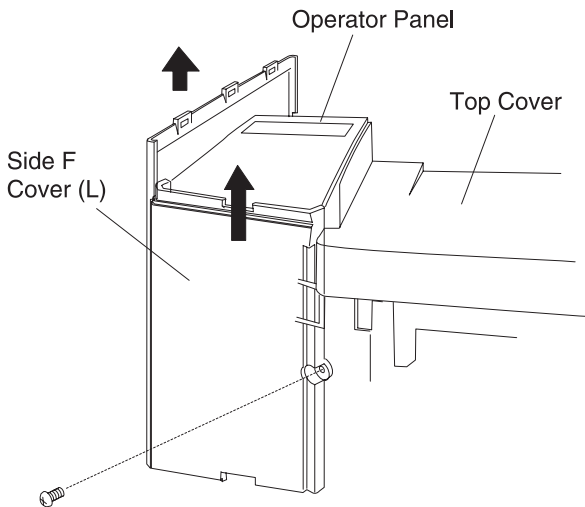

## Top Cover Assembly Removal

1. Open the paper exit unit and front cover unit. See **“Printer Covers” on page 4-6**, for more information.
2. Remove the upper side cover (L). See **“Upper Side Cover (L) Removal” on page 4-7**, for more information.
3. Remove the side cover (R). See **“Side Cover (R) Removal” on page 4-8**, for more information.
4. Remove the top cover assembly.

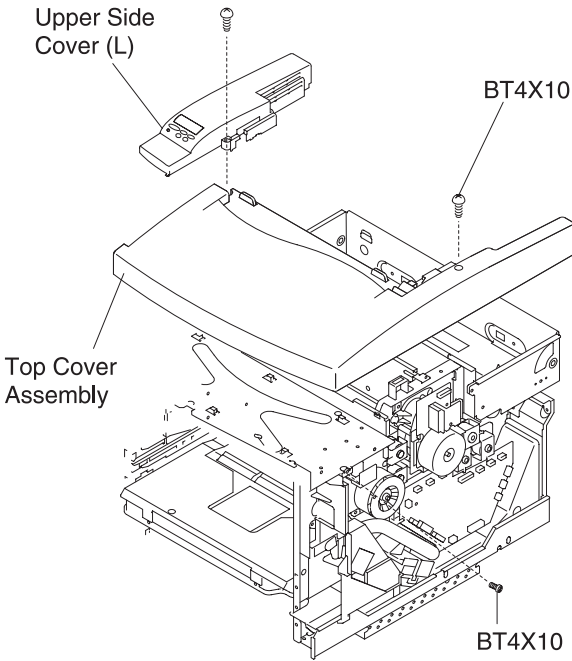

## **Paper Exit Cover / Paper Exit Front Cover / Paper Exit Cover (U) Removal**

1. Open the paper exit unit. See **“Printer Covers” on page 4-6**, for more information.
2. Remove the fusing unit. See **“Fuser Unit Removal” on page 4-93**, for more information.
3. Remove the paper exit unit. See **“Paper Exit Unit / Paper Exit Roller Removal” on page 4-86**, for more information.
4. Remove the screws BT3X8 (4) from the paper exit front cover (L).
5. Remove the paper exit front cover from the paper exit unit.
6. Remove the screws BT3X8 (4) of the paper exit cover assembly.

7. Remove the paper exit cover assembly from the paper exit unit.

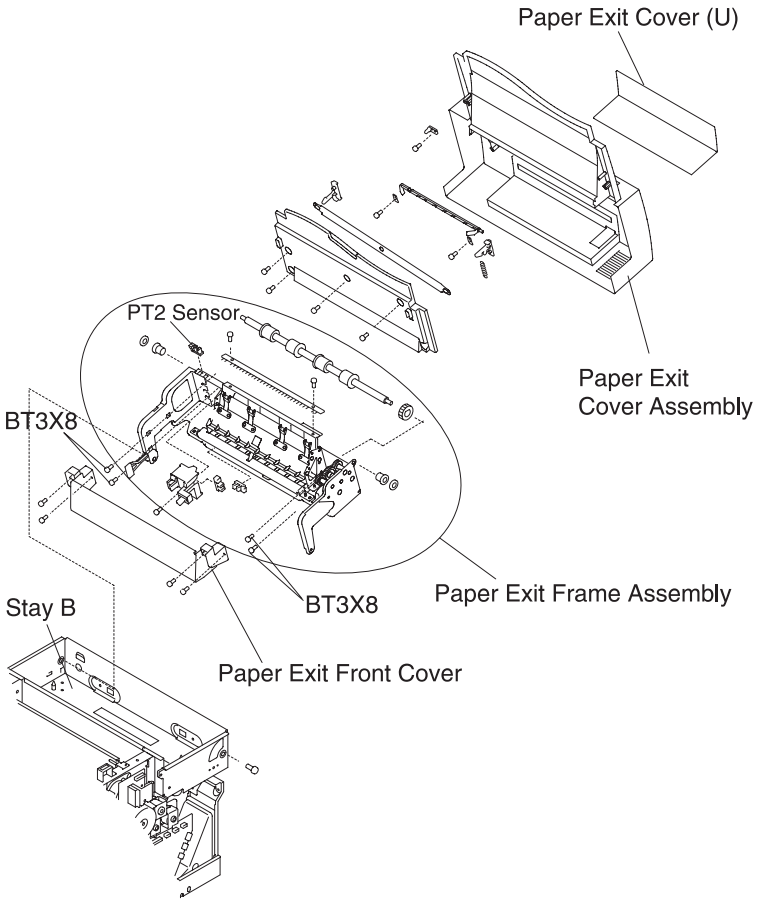

## Transfer Cover Removal

1. Open the transfer unit. See **“Printer Covers”** on page 4-6, for more information.
2. Remove the fixing screw BT4x10 (1) from the band setting of the transfer unit.
3. Holding the transfer unit horizontally, remove the set screw (1) and bracket from the left edge of the transport support.
4. Remove the transfer unit.
5. Remove the fixing screws BT3X8 (4) of the transfer cover.
6. Remove the transfer cover from the transfer unit.

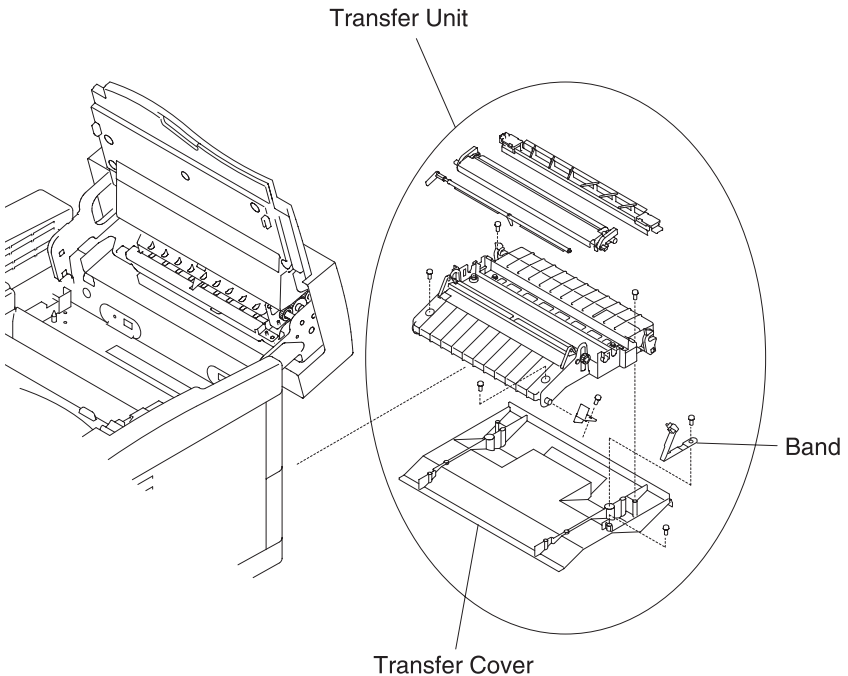

## Rear Cover Removal

1. Unplug the power cable from the printer.
2. Remove the screw BT4X10 (1) from the rear cover.

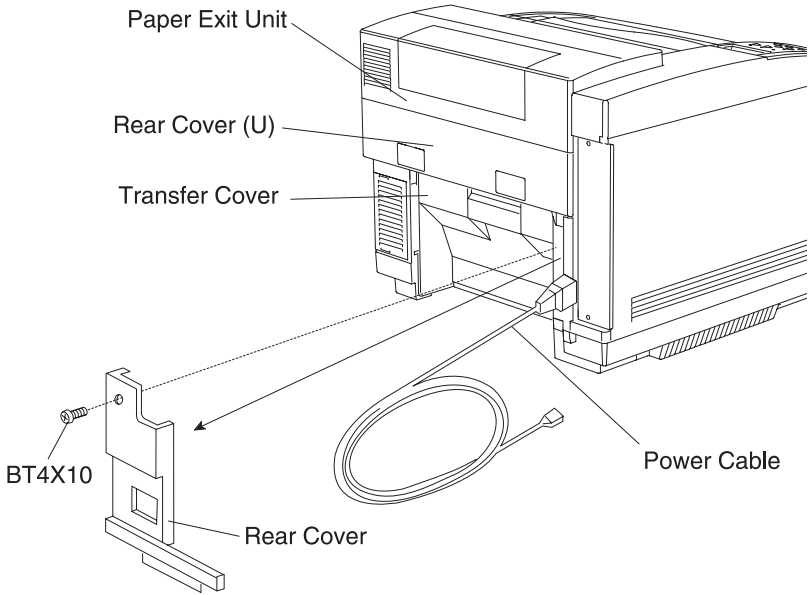

**Note:** After installing the new rear cover, plug in the power cable.

## Rear Cover (U) Removal

1. Open the transfer unit. See **“Printer Covers”** on page 4-6, for more information.
2. Unplug the power cable from the electrical outlet.
3. Remove the side cover (R). See **“Side Cover (R) Removal”** on page 4-8, for more information.
4. Remove the rear cover. See **“Rear Cover Removal”** on page 4-16, for more information.
5. Remove the hooks (2) from the rear cover (U) on the frame.
6. Remove the rear cover (U) with the rear cover (U) cap.

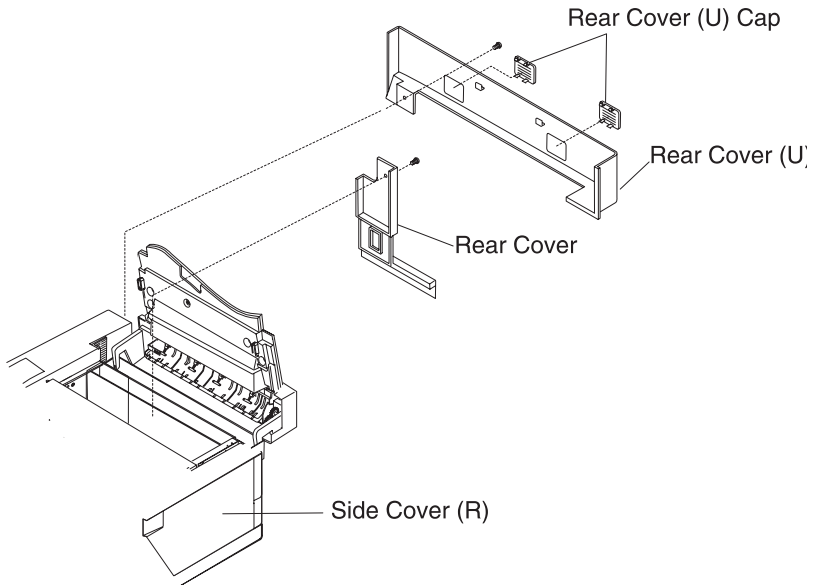

## Base Cover (R) Removal

1. Remove the side cover (R). See **“Side Cover (R) Removal”** on page 4-8, for more information.
2. Remove the set screws BT4X10 (2) from the base cover (R).
3. Remove the base cover (R) from the base.
  - a. Pull and remove the rear side.
  - b. Pull and remove the front side.

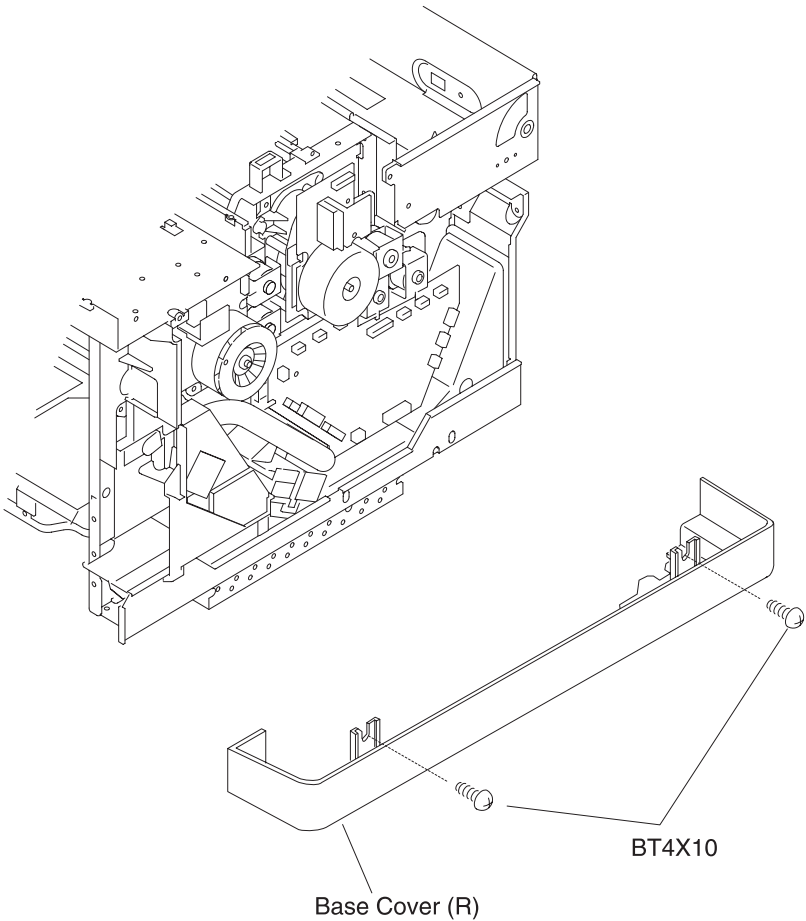



**WARNING:**

- When assembling the base cover, insert the leading edge of base cover (R) into the hooks (2) provided at the bottom (left and right) of the base plate.
- Have the projecting part of the base cover (R) meet the holes (2) of the base plate bottom.

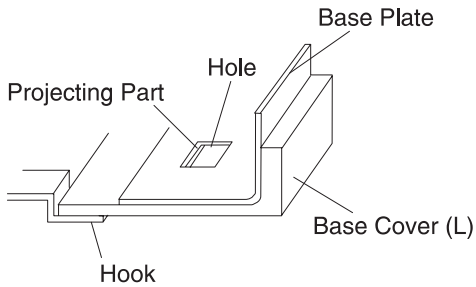

## Base Cover (L) Removal

1. Remove the side cover (L). See **“Side Cover (L) Removal”** on **page 4-10**, for more information.
2. Remove the set screws BT4X10 (2) from the base cover (L).
3. Remove the base cover (L) from the base.
  - a. Pull and remove the rear side.
  - b. Pull and remove the front side.

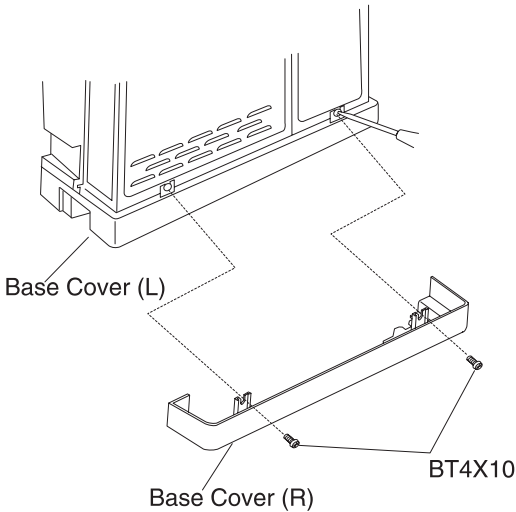

### WARNING:

- When assembling the base cover, insert the leading edge of the base cover (L) into the hooks (2) provided at the bottom (left and right) of the base plate.

## 5024-001

- Have the projecting part of the base cover (L) meet the holes (2) of the base plate bottom.

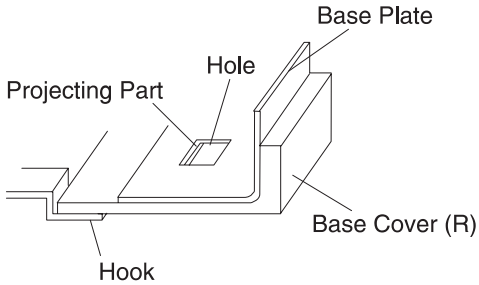

## Cleaner Cover Removal

1. Open the paper exit unit.
2. Holding the knob, remove the cleaner cover.

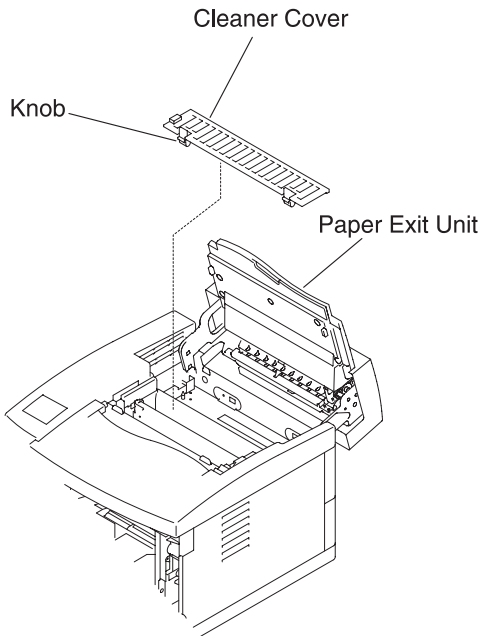

## Front Cover Removal

1. Open the front cover unit.
2. Remove the set screws BT4X10 (2) from the front cover.
3. Unhook the hooks (4, left and right), and remove the front cover from the front cover unit.

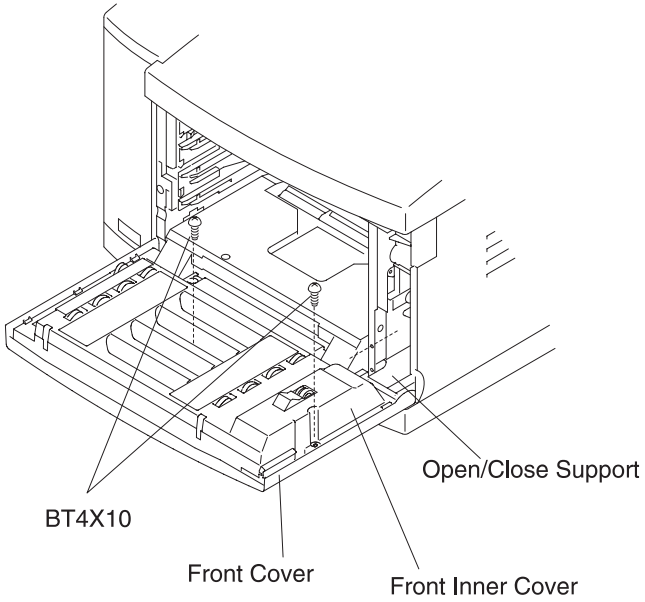

---

# Printer Board Removals

## Printer Board Layout

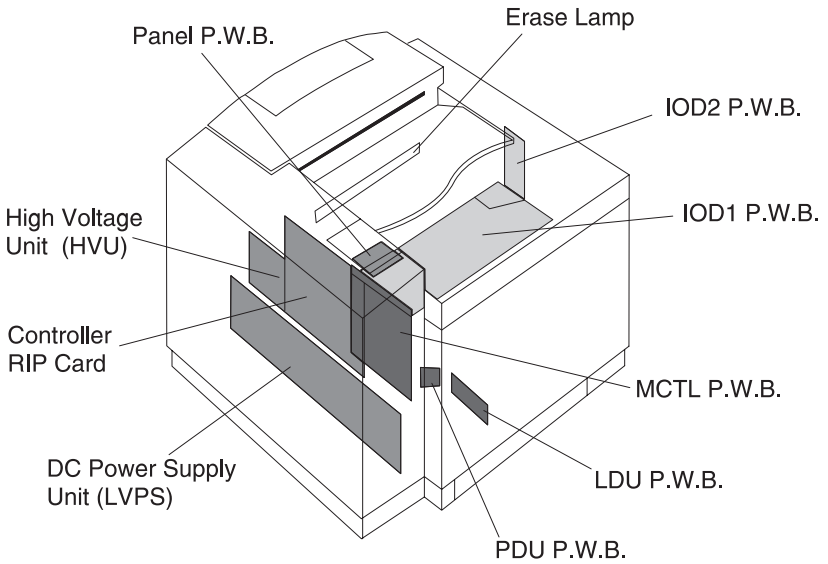

## Main Engine (MCTL P.W.B.) Board Removal

1. Remove the side cover (L). See **“Side Cover (L) Removal” on page 4-10**, for more information.
2. Remove the set screw TS3X6 (1) from shield cover B.
3. Disconnect all harness connectors to the main engine (MCTL P.W.B.) board (8).
4. Remove the set screw TS3X6 (4) from the main engine (MCTL P.W.B.) board
5. Remove the main engine (MCTL P.W.B.) board.

After performing the reverse removal steps:

1. Connect the power supply cable.
2. Turn the printer On.
3. Check the margin adjustment. See **“Adjustments” on page 4-4**, for more information.
4. Confirm printer operation and print quality by executing test print. See **“Diagnostic Mode” on page 3-5**, for more information.

### WARNING:

- Read the information contained in the NVRAM prior to replacing the main engine (MCTL P.W.B.) board.
- When replacing the main engine (MCTL P.W.B.) board, use caution against electrostatic discharge.

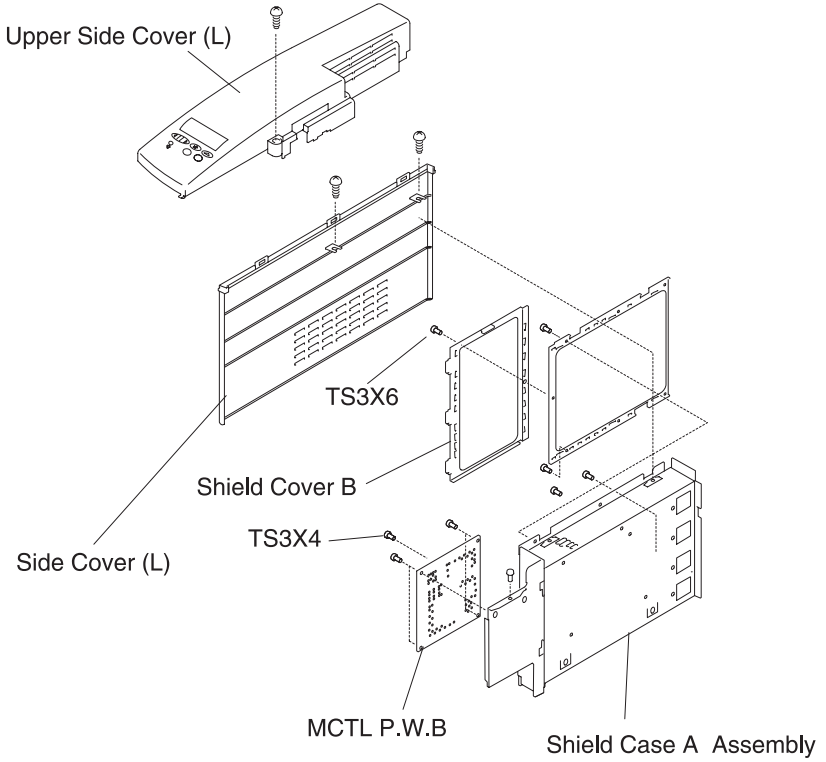

## IOD1 P.W.B. Removal

1. Remove the upper side cover (L). See **“Upper Side Cover (L) Removal” on page 4-7**, for more information.
2. Remove the top cover. See **“Top Cover Assembly Removal” on page 4-12**, for more information.
3. Remove the set screws ST3X6 (4) from the shield cover (upper).
4. Remove the shield cover (upper).
5. Disconnect all harness connectors (16) to the IOD1 P.W.B.
6. Remove the set screws ST3X6 (6) from the IOD1 P.W.B.
7. Remove the IOD1 P.W.B.

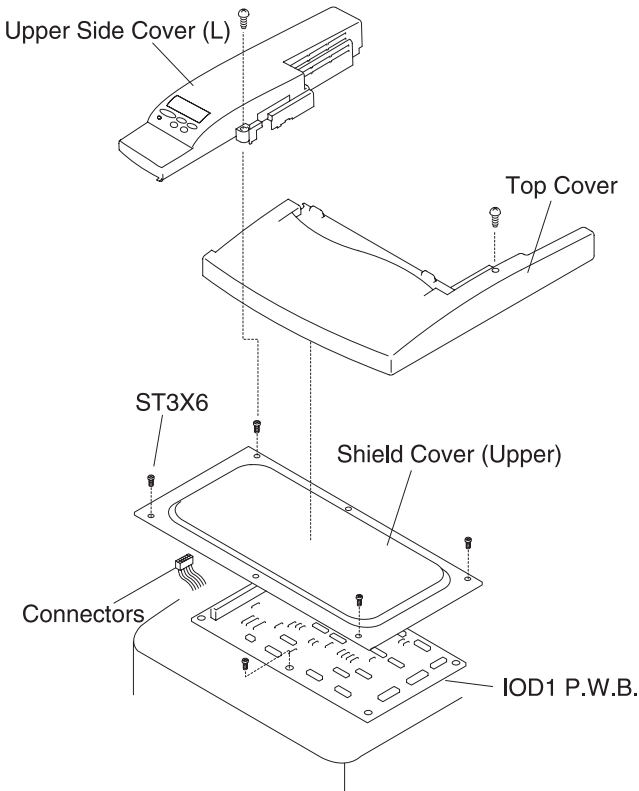



## 5024-001

After performing the reverse removal steps:

1. Reconnect the power supply cable.
2. Turn the printer On.
3. Execute the test print in service mode. See **“Diagnostic Mode” on page 3-5**, for more information.
4. Confirm printer operation and print quality.

**WARNING:** When replacing the IOD1 P.W.B., use caution against electrostatic discharge.

## IOD2 P.W.B. Removal

1. Remove the side cover (R). See **“Side Cover (R) Removal” on page 4-8**, for more information.
2. Remove all harness connectors to the IOD2 P.W.B. (16).
3. Remove the fixing screws ST3X6 (5) from the IOD2 P.W.B.
4. Remove the IOD2 P.W.B. from the base.

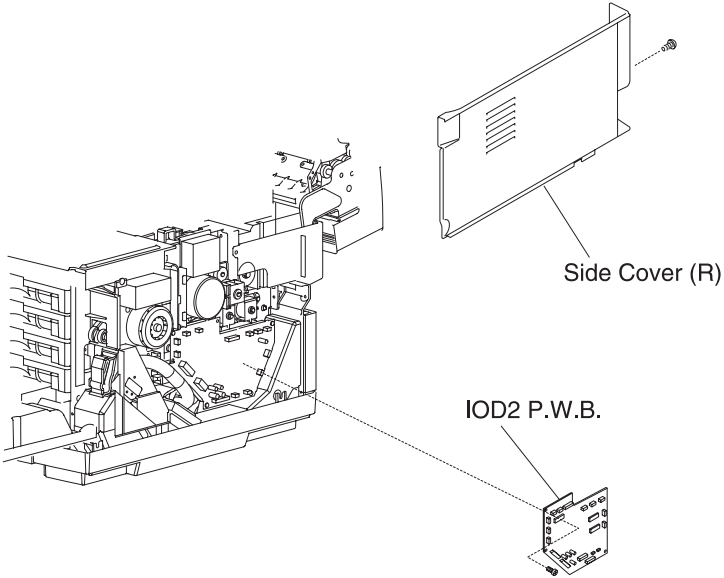

After performing the reverse removal steps:

1. Reconnect the power supply cable.
2. Turn the printer On.
3. Execute the test print in the service mode. See **“Diagnostic Mode” on page 3-5**, for more information.
4. Confirm printer operation and print quality.

## Panel P.W.B. (Operator Control) Removal

1. Remove the upper side cover (L). See **“Side Cover (L) Removal” on page 4-10**, for more information.
2. Slide the operator panel assembly to the right and lift away from the control panel base.
3. Disconnect the operator panel connector.

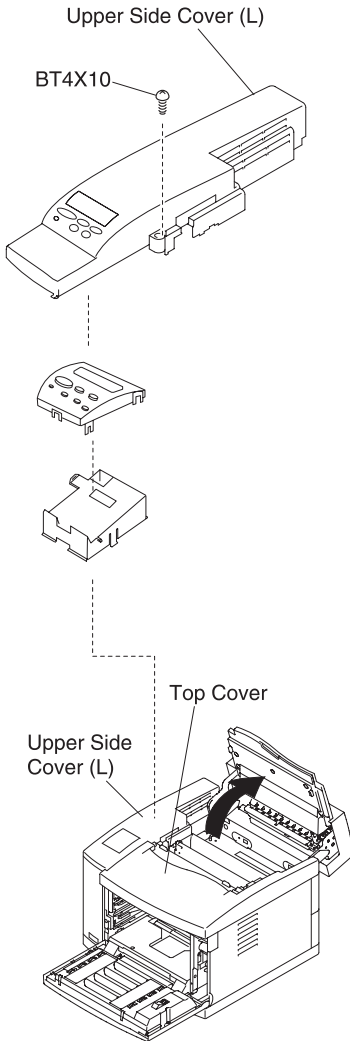

## Power Supply Unit (Low Voltage Power Supply - LVPS) Removal

1. Remove the base cover (L). See **“Base Cover (L) Removal” on page 4-20**, for more information.
2. Remove the side F cover (L). See **“Side F Cover (L) Removal” on page 4-11**, for more information.
3. Remove the upper side cover. See **“Upper Side Cover (L) Removal” on page 4-7**, for more information.
4. Remove the side cover (L). See **“Side Cover (L) Removal” on page 4-10**, for more information.
5. Remove the rear cover. See **“Rear Cover Removal” on page 4-16**, for more information.
6. Remove the set screw ST3X6 (1) from the shield cover B. See the illustration **“Main Engine (MCTL P.W.B.) Board Removal” on page 4-24**, for location.
7. Remove the set screws ST3X6 (2) from the shield cover A. See the illustration **“Main Engine (MCTL P.W.B.) Board Removal” on page 4-24**, for location.
8. Remove the controller card.
9. Remove the set screws ST3X6 (2) from the side cover F and panel base.
10. Remove the switch.
11. Disconnect all harness connectors to the main engine (MCTL P.W.B.) board.
12. Remove side cover F.
13. Remove the screw F3X6 (1) from the controller fan assembly.
14. Remove the set screws ST3X6 (4) from the shield case A assembly.
15. Remove the shield case A assembly.
16. Remove the set screws ST3X6 (2) from the bottom stay (L).
17. Disconnect all harness connectors to the power supply unit (5).
18. Remove the set screw ST3X6 (2) from the inlet base.
19. Remove the set screw M4X6 (brass, with washer) from the ground wire.
20. Remove the set screws ST3X6 (2) from the power supply unit.

## 5024-001

21. Remove the low voltage power supply unit from the printer engine.
  - a. Pull out the front part of the power supply.
  - b. Remove the hook from the frame base hole.
  - c. Remove the power supply unit from the engine.

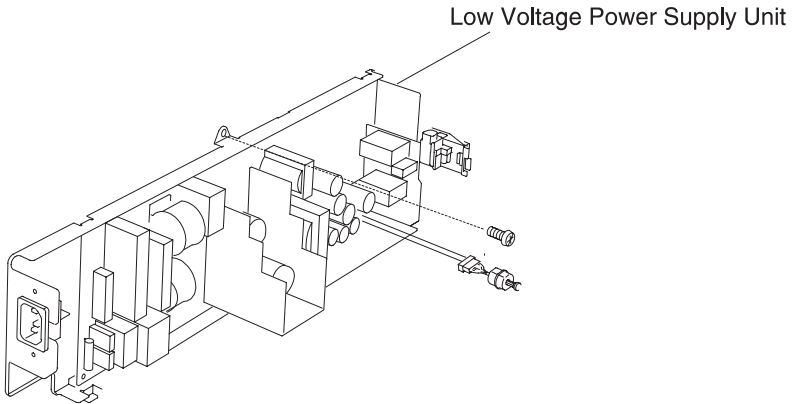

### Power supply installation:

1. Install the new power supply unit to the printer engine.
2. Perform the reverse removal steps.
3. Reconfirm the ground wire is connected to the ground position on the frame.
4. Turn the printer On.
5. Confirm printer operation.

**CAUTION:** The ground wire is important in securing the safety of users. Upon removal of the power supply unit, confirm that the ground wires (green and yellow) are securely connected to the .

**Note:** This illustration is used for both low and high voltage power supply removal.

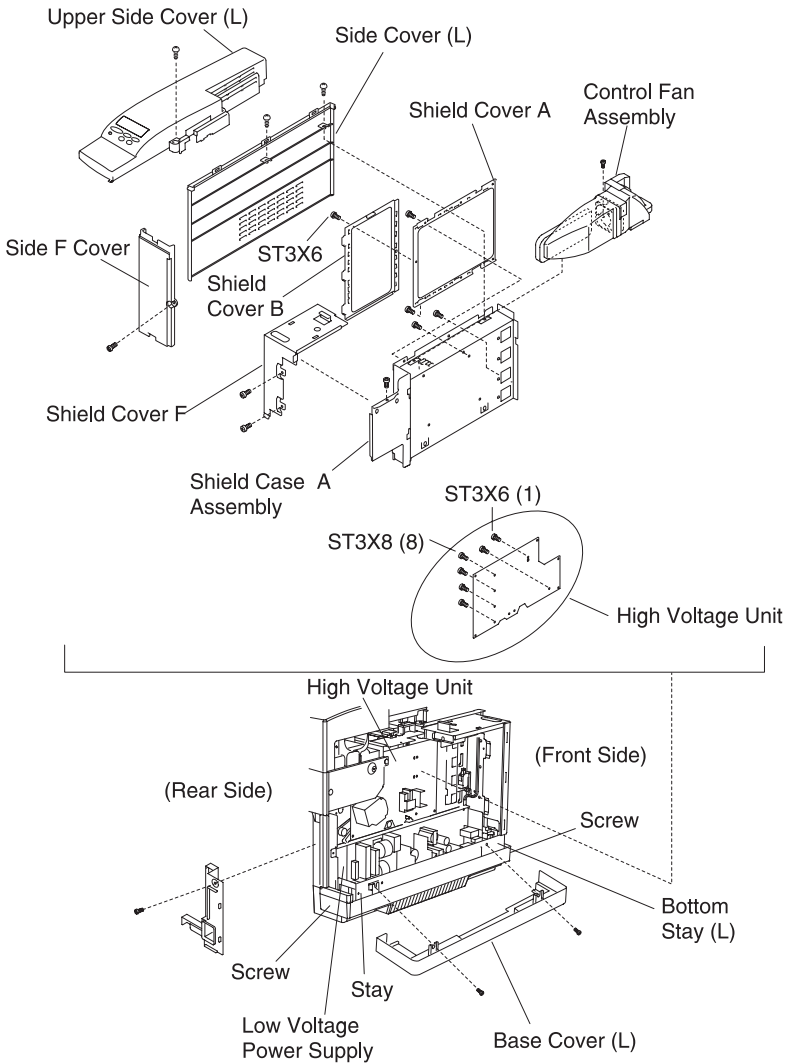

## High Voltage Power Supply Unit (HVU) Removal

1. Remove the upper side cover (L). See **“Upper Side Cover (L) Removal” on page 4-7**, for more information.
2. Remove the side cover (L). See **“Side Cover (L) Removal” on page 4-10**, for more information.
3. Remove the controller board.
4. Remove the shield cover B.
5. Remove the shield cover A.
6. Disconnect all harness connectors (8) to the main engine (MCTL P.W.B.) board.
7. Remove the screw F3X6 (1) from the controller fan assembly, and the case. See **“Side Cover (L) Removal” on page 4-10**, for more information.
8. Remove the set screws ST3X6 (4) from the shield case A assembly and remove shield case A assembly.
9. Remove rear screw from base cover (L).
10. Disconnect all harness connectors (3) to the high voltage unit.
11. Remove the set screws ST3X6 (1) and BT3X8 (8) from the high voltage unit.
12. Remove the high voltage unit.

### Power supply installation:

1. To install a new high voltage unit:
  - a. Put each electrode terminal through the holes of the P.W.B. from the back.
  - b. Having the set holes for the electrode meet the installation hole of the P.W.B., replace the screws.
2. Perform the reverse removal steps.
3. Connect the power supply cable.
4. Turn the power On.
5. Execute the test print in service mode. See **“Diagnostic Mode” on page 3-5**, for more information.
6. Confirm printer operation and print quality.

**CAUTION:** The high voltage unit generates high voltage (5KV). You may get an electric shock, if you touch the unit while it is powered on. Therefore, turn On the unit only after having installed the side cover (L).

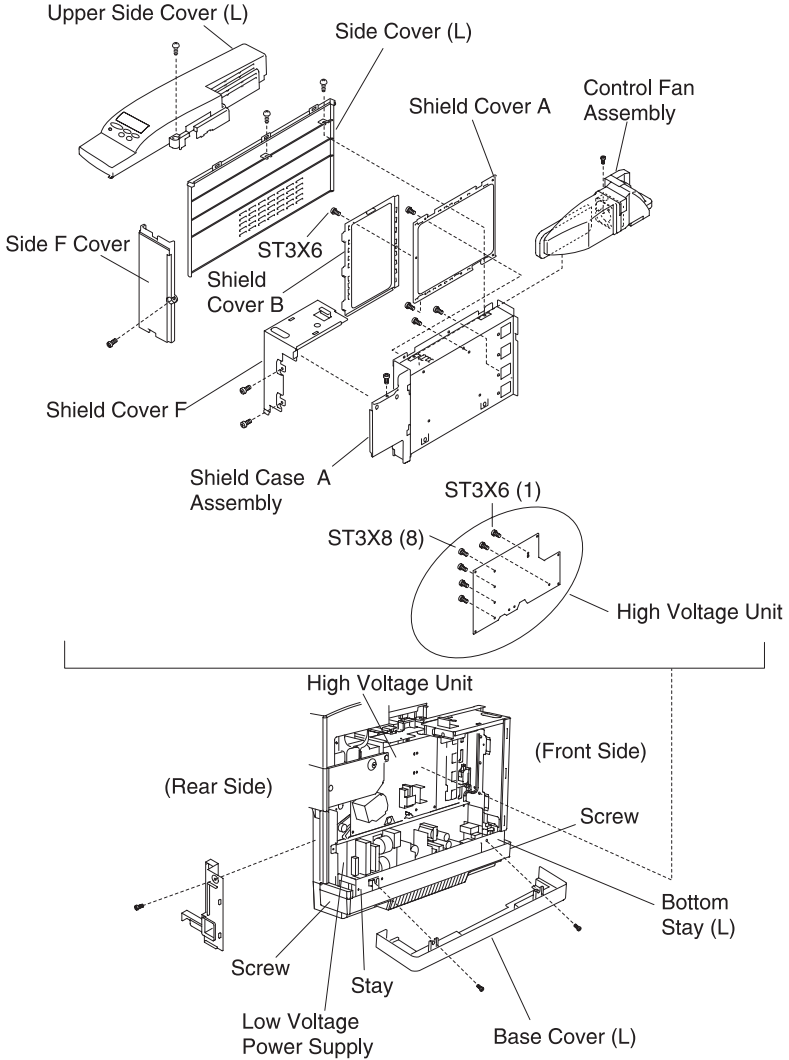



## Erase Lamp Removal

1. Open the front cover. See **“Front Cover Removal”** on **page 4-22**, for more information.
2. Open the paper exit unit. See **“Paper Exit Cover / Paper Exit Front Cover / Paper Exit Cover (U) Removal”** on **page 4-13**, for more information.
3. Pull out the toner cartridge (C/M/Y/K).
4. Pull out the belt OPC cartridge.
5. Remove the erase lamp P.W.B. from the holders (2) at the front side.
6. Disconnect the erase lamp harness connector.
7. Remove the erase lamp.

**WARNING:** Do not touch the transfer drum with your hands while removing or reassembling the erase lamp.

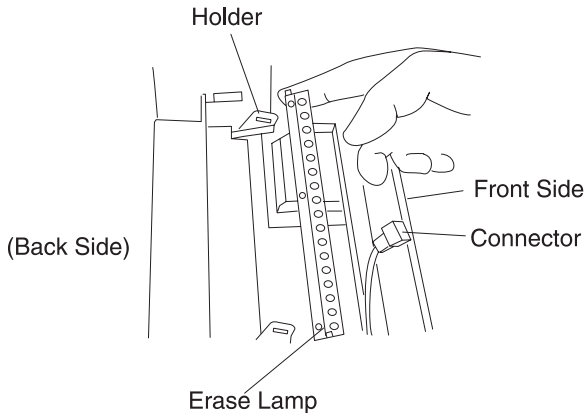

After performing the reverse removal steps:

1. Connect the power supply cable.
2. Turn the printer On.
3. Execute the test print in the service mode. See **“Diagnostic Mode”** on **page 3-5**, for more information.
4. Confirm printer operation and print quality.

**5024-001**

**WARNING:** The erase lamp has directional characteristics, if installed in the wrong direction. The transfer drum may be damaged.

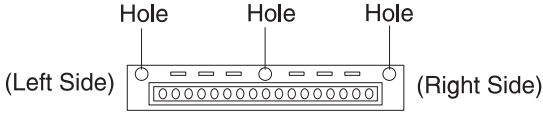

## Motor Removals

### Fan / Motor Layout

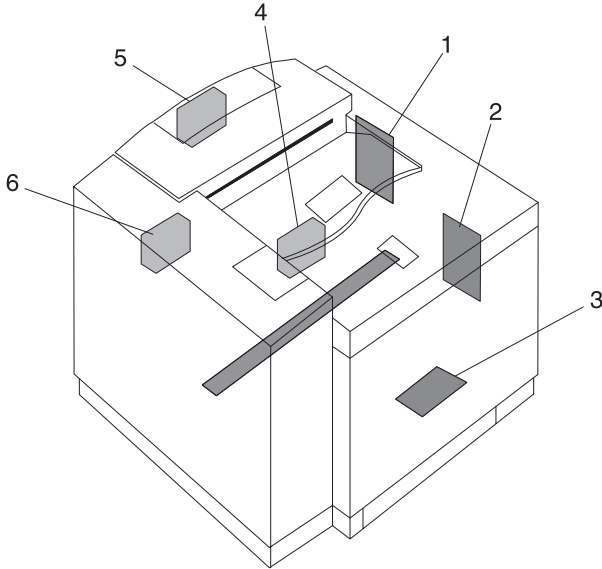

Name	Code	Function
1 Main Motor	M M	Drives the OPC belt and the paper transport system.
2 Developer Motor	D M	Drives the toner cartridge and the developing system.
3 Scanner Motor	S C M	Scans the laser beam in the optical unit.
4 Controller Fan	CTLFAN	Exhausts the heat from the power supply unit and the interface controller.
5 Heater Fan	HTFAN	Exhausts the heat from the fusing unit.
6 Ozone Fan	OZFAN	Exhausts the ozone from the printer charger unit.

## Main Motor (MM) / BD Gear Assembly Removal

1. Remove the side cover (R). See **“Side Cover (R) Removal” on page 4-8**, for more information.
2. Remove the top cover assembly. See **“Top Cover Assembly Removal” on page 4-12**, for more information.
3. Remove the connector to the main motor.
4. Remove all connectors to the IOD2 P.W.B. See **“IOD2 P.W.B. Removal” on page 4-28**, for more information.
5. Remove the fixing screws ST3X6 (2) from the IOD2 P.W.B. base assembly.
6. Remove the IOD2 base assembly.
7. Remove the fixing screws ST3X6 (3) from the BD gear assembly.
8. Remove the BD gear assembly.
9. Remove the fixing screws BT3X8 (4) from the main motor.
10. Remove the main motor from the BD gear assembly.

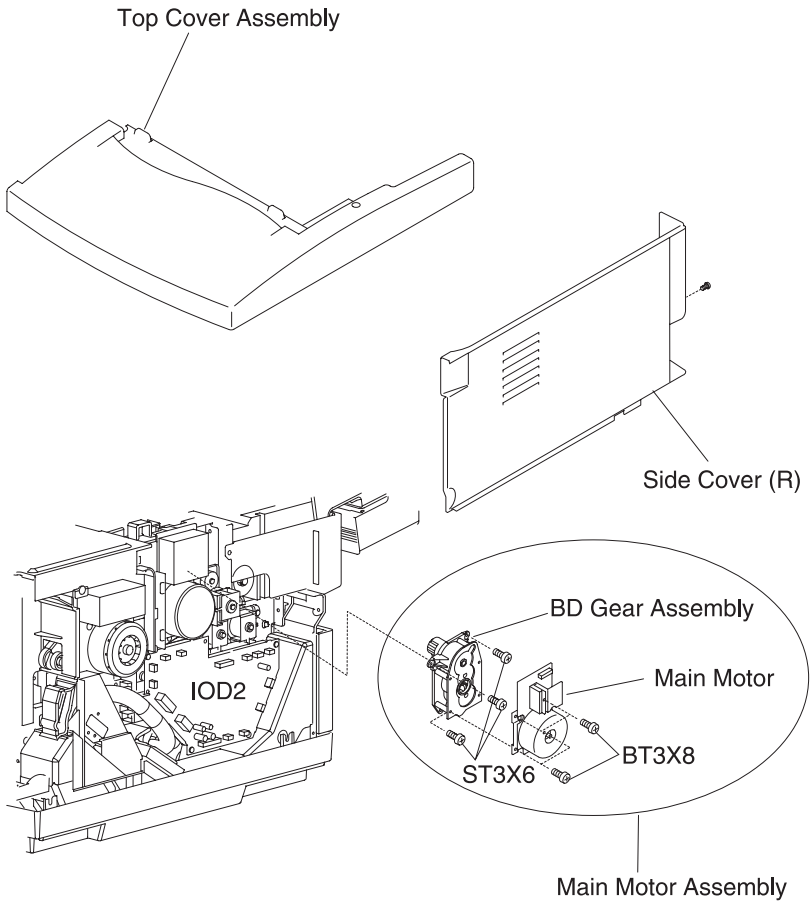

**Notes:**

1. Assemble the main motor and BD gear assembly.
2. Install the main motor assembly to the engine frame.
3. Perform the reverse removal steps.

## Main Gear Unit Removal

1. Remove the fusing unit.
2. Remove the main motor assembly. See **“Main Motor (MM) / BD Gear Assembly Removal”** on page 4-38, for more information.
3. Remove the set screws ST3X6 (4) from the main drive unit.
4. Remove the main drive unit from the frame.

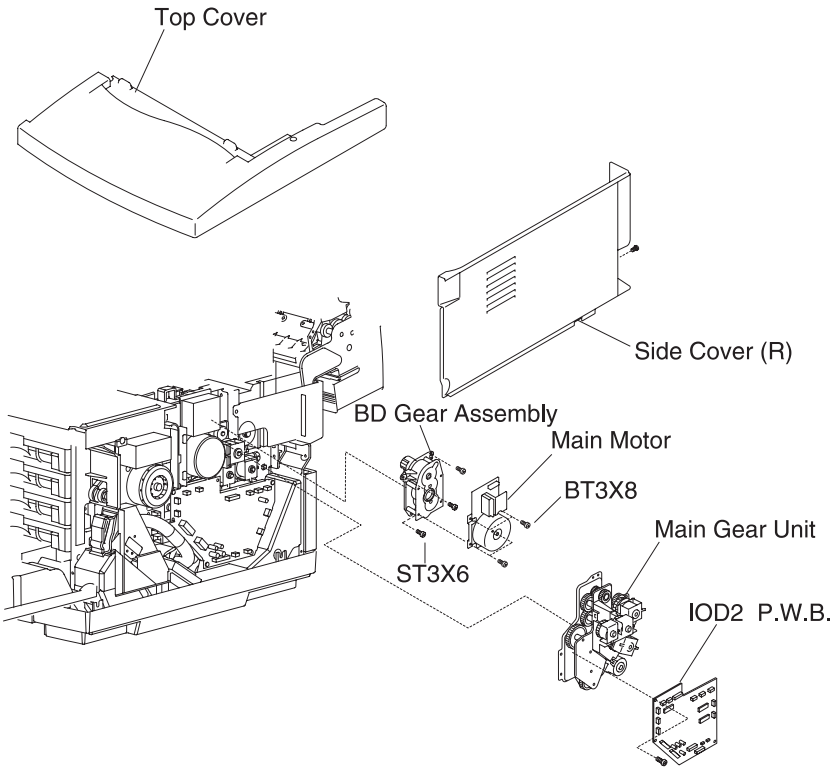

## Developer Motor (DM) Removal

1. Remove the toner cartridges.
2. Remove side cover (R). See **“Side Cover (R) Removal” on page 4-8**, for more information.
3. Disconnect CN1 connected to the developer motor P.W.B.
4. Remove the fixing screws F3X10 (4) from the developer motor.
5. Remove the developer motor from the developer drive unit.

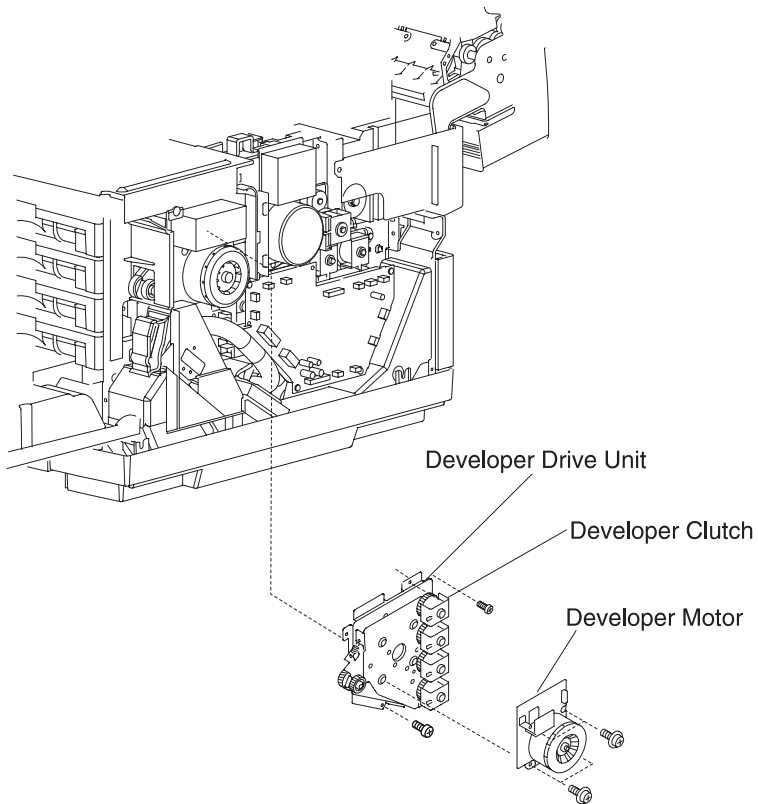

## Developer Drive Unit Removal

1. Remove the toner cartridges.
2. Remove the waste toner bottle.
3. Remove side cover (R). See **“Side Cover (R) Removal” on page 4-8**, for more information.
4. Remove the base cover (R). See **“Base Cover (R) Removal” on page 4-18**, for more information.
5. Remove the screw BT3X8 (1) from the cover (RF).
6. Remove the IOD2 base assembly.
7. Remove the front set screw ST3X6 (1) from the base frame (R).
8. Remove the set screw ST3X6 (1) from the waste toner holder assembly.
9. Remove the WT holder assembly.
10. Remove the developer motor. See **“Developer Motor (DM) Removal” on page 4-41**, for more information.
11. Remove the OPC belt cartridge.
12. Remove the washers (4) from each developer drive gear located inside printer.
13. Remove the developer drive gear for each color from the inside.
14. Remove the set screw ST3X6 (4) from the developer gear unit.
15. Remove the developer drive unit from the frame.



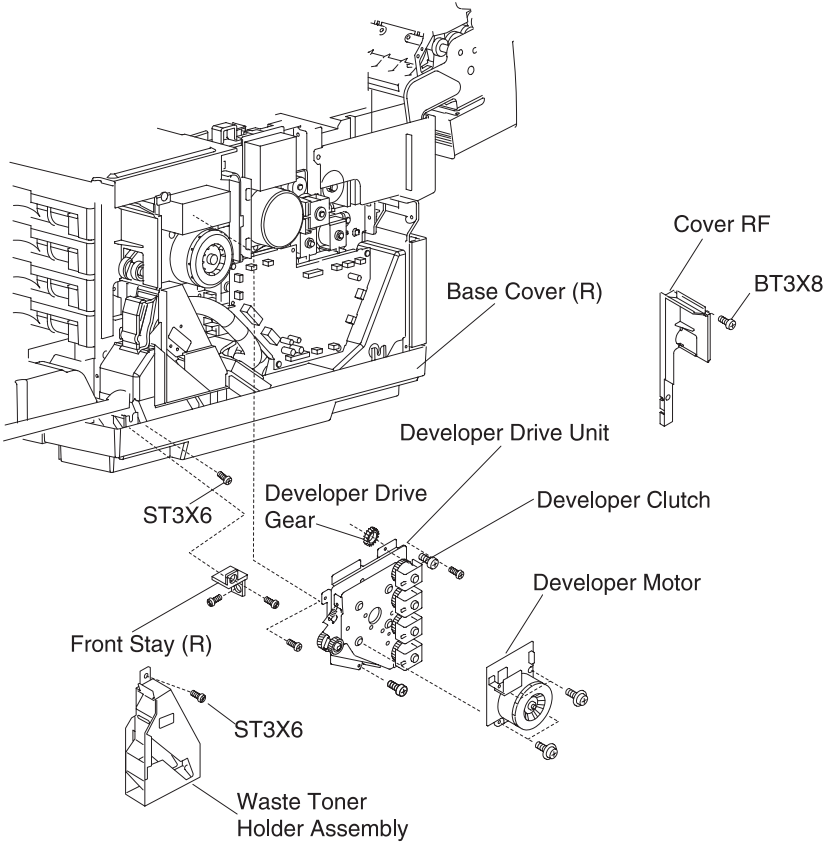

## Optical Unit (Printhead Scanner Motor Assembly) Removal

1. Remove the toner cartridges.
2. Remove the OPC belt cartridge.
3. Remove cover 'C' from inside the printer.

After removing the hooks (3 inside) and locks (2 front side), cover C can be pulled toward you for removal.

4. Remove the fixing screws FT3X10 (4) from the optical unit.
5. Disconnect the optical unit.

6. Remove the optical unit from inside the printer.

**CAUTION:** Laser WARNING label

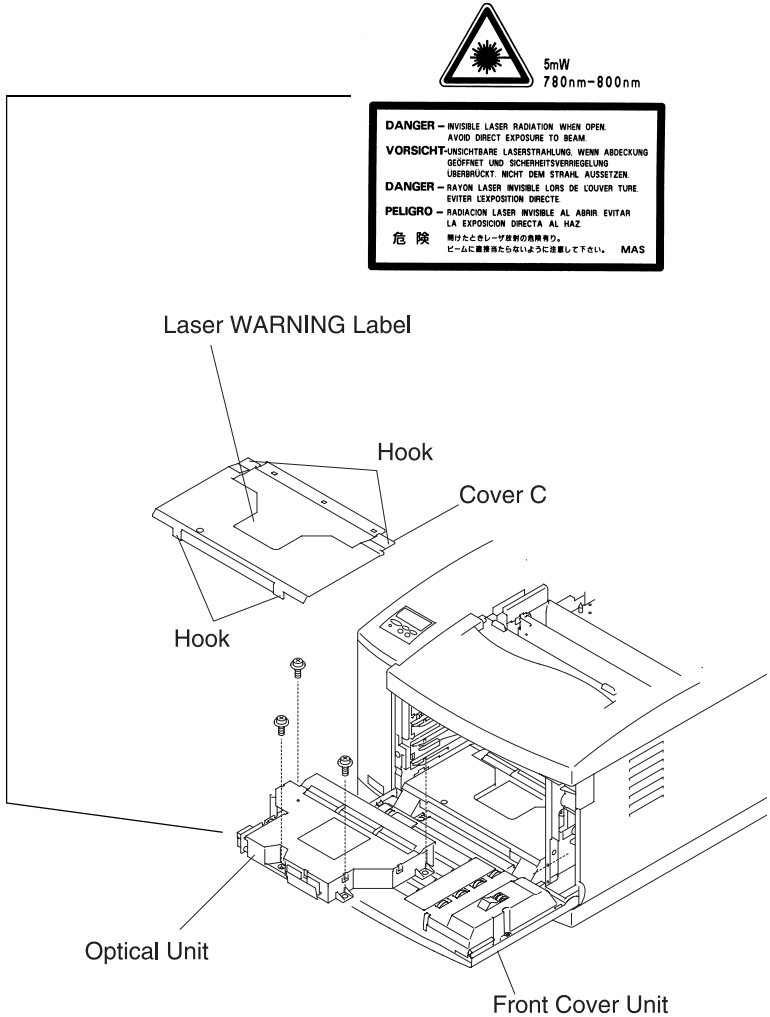

**Notes:**

1. When the optical unit meets the positioning boss, install it into the printer base.
2. Perform the reverse removal steps.

**CAUTION:**

1. There is a class B laser within the optical unit. Do not attempt to disassemble the laser.
2. The optical unit is replaced as a whole unit. No adjustment is required.
3. Confirm all covers have been installed prior to any test run or operation, in order to prevent any laser radiation from occurring.

## Control Fan (3) (CTFAN) Removal

1. Remove the upper side cover (L). See **“Upper Side Cover (L) Removal” on page 4-7**, for more information.
2. Remove the side cover (L). See **“Side Cover (L) Removal” on page 4-10**, for more information.
3. Remove the top cover assembly. See **“Top Cover Assembly Removal” on page 4-12**, for more information.
4. Remove the screws ST3X6 (4) from the shield cover (upper).
5. Remove the set screw F3X6 (1) in the control fan case assembly.
6. Disconnect the harness connector.
7. Remove the set screw BT3X8 on the fan case.

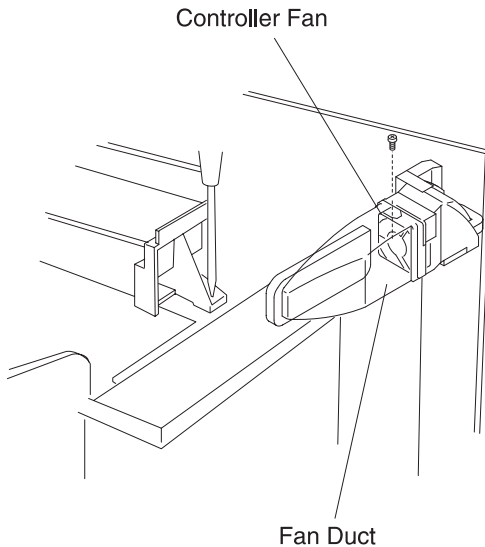

8. Open and unhook the fan case and remove the fan motor.
9. Remove the interlock switch top.

### Notes:

- Ensure the interlock switch is reinstalled properly. See **“Interlock Switch (Top) Removal” on page 4-60**, for more information.

**5024-001**

- Confirm that the interlock switch (top) operates properly.

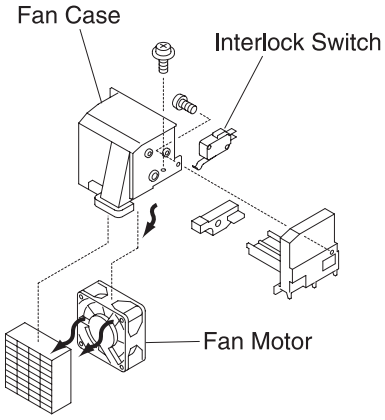

## Heater Fan (HTFAN) Removal

1. Remove the paper exit cover. See “**Paper Exit Cover / Paper Exit Front Cover / Paper Exit Cover (U) Removal**” on **page 4-13**, for more information.
2. Remove the connectors to the heater fan.
3. Unhook the heater fan case assembly from the paper exit frame assembly.
4. Remove the heater fan from the heater fan case assembly.

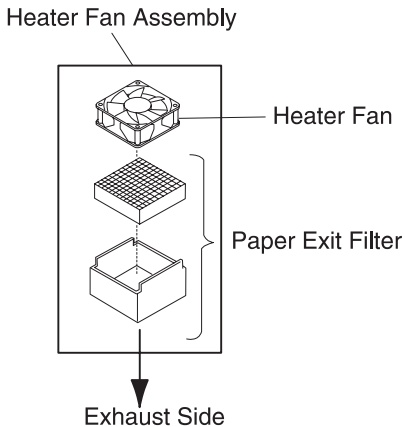
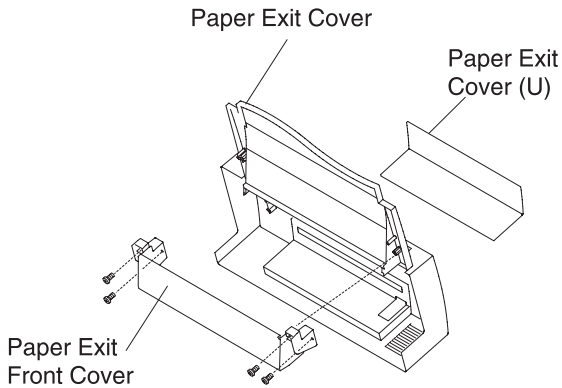

**WARNING:** When installing the heater fan, make sure the rating label on the fan motor faces the exhaust side.

## Ozone Fan (OZFAN) / Ozone Duct Assembly Removal

1. Remove the side cover (R). See **“Side Cover (R) Removal”** on page 4-8, for more information.
2. Remove the base cover (R). See **“Base Cover (R) Removal”** on page 4-18, for more information.
3. Disconnect all connectors from the IOD2 P.W.B. (16).
4. Remove the fixing screws ST3X6 (2) from the IOD2 P.W.B. with base.
5. Remove the fixing screws ST3X6 (5) from the stay (R).
6. Remove the stay (R) from the frame.
7. Remove the fixing screws ST3X6 (2) from the waste toner holder assembly.
8. Remove the waste toner holder assembly from the frame.
9. Remove the ozone duct.
10. Remove the fixing screw F3X6 (1) from the ozone fan case.
11. Remove the ozone fan case.
12. Open the ozone fan case and remove the ozone fan.

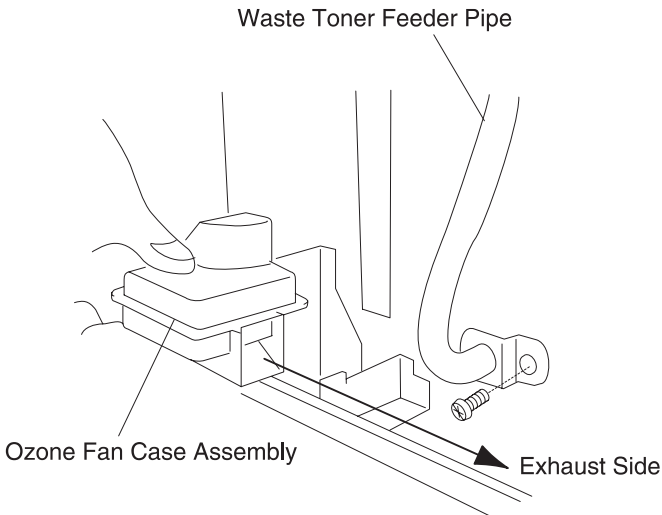



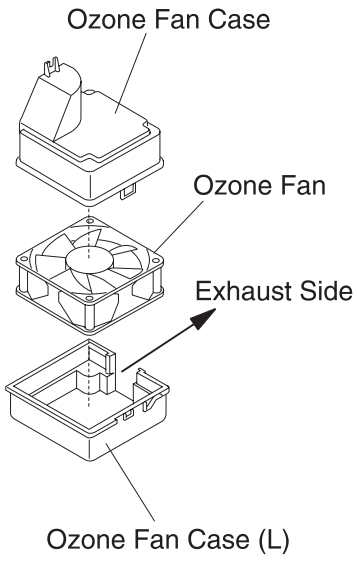

---

## Clutch and Solenoid Removals

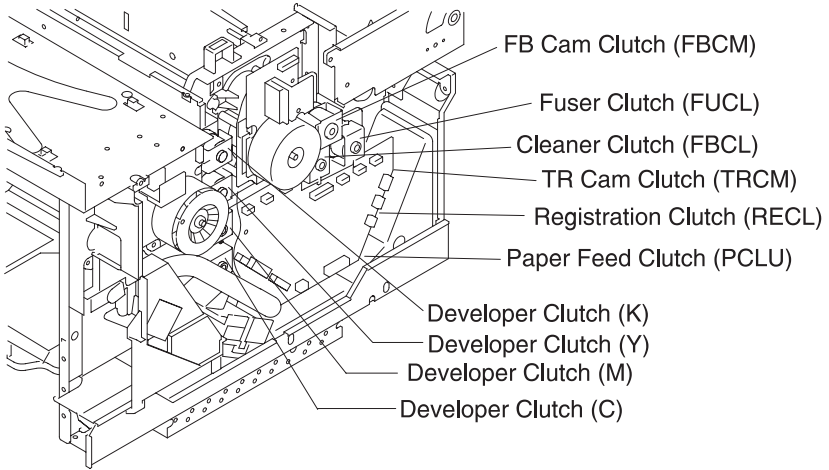

## Clutch (FUCL, FBCL, RECL) Removal

1. Remove the side cover (R). See **“Side Cover (R) Removal”** on **page 4-8**, for more information.
2. Remove the harness connector, of applicable clutch, from the IOD2 P.W.B.
3. Remove the washer, of applicable clutch, from the shaft.
4. Pull out clutch from the shaft.

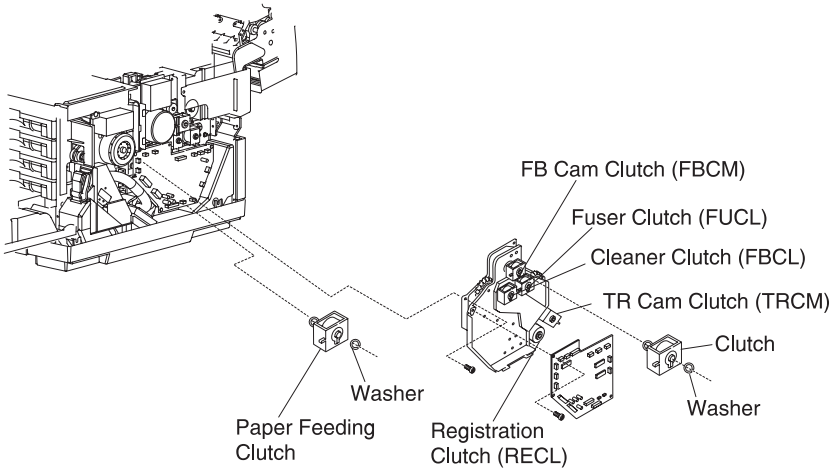

## Paper Feeder Clutch (PCLU) Removal

1. Remove the IOD2 P.W.B. See **“IOD2 P.W.B. Removal”** on **page 4-28**, for more information.
2. Remove the washer, of the paper feeder clutch, from the shaft.
3. Pull out the paper feeder clutch from the shaft.

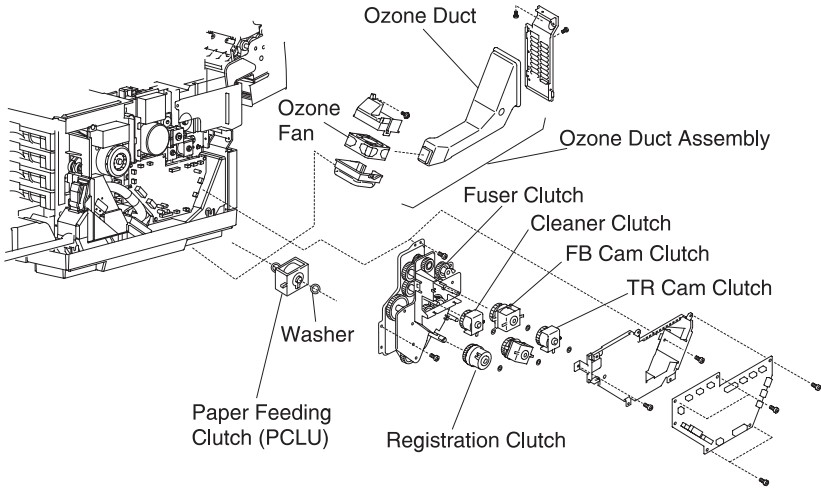

## Developer Clutch (DCLK, DCLY, DCLM, DCLC) Removal

1. Remove the side cover (R). See **“Side Cover (R) Removal” on page 4-8**, for more information.
2. Remove IOD2 P.W.B., if necessary. See **“IOD2 P.W.B. Removal” on page 4-28**, for more information.
3. Remove the washer from the applicable clutch.

4. Pull out the clutch from the developer drive gear.

**Note:** This clutch is common for all four colors.

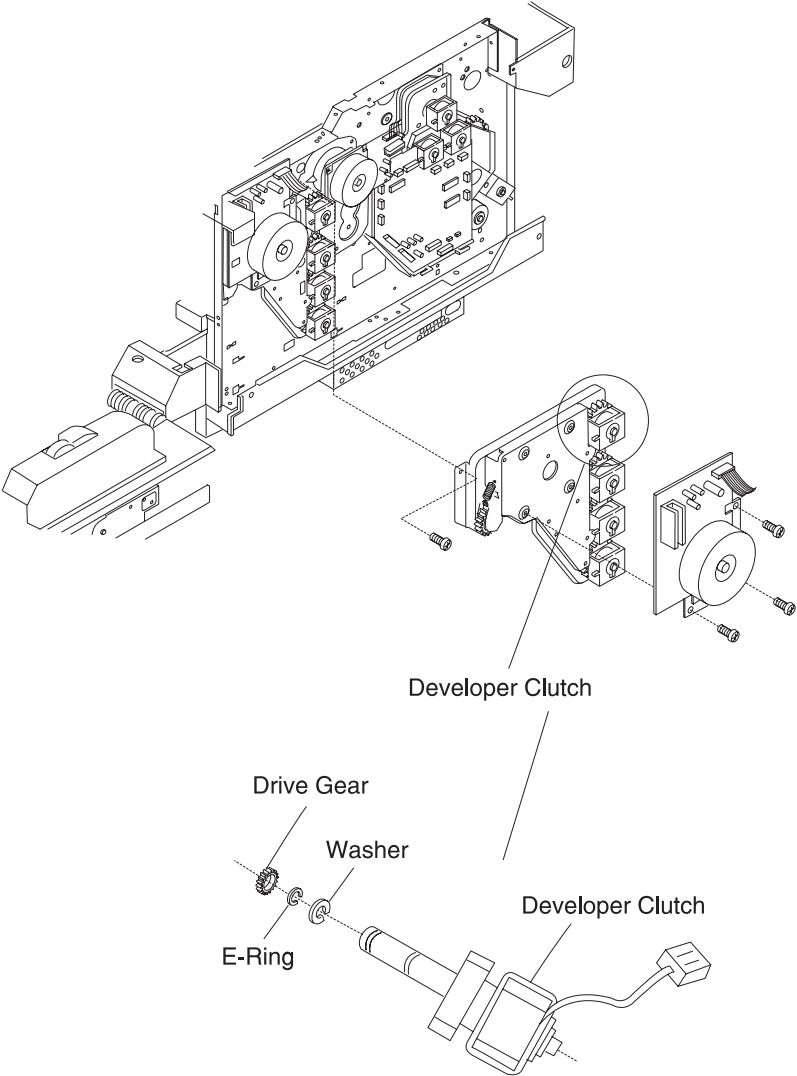

## Cam Clutch (FBCM, TRCM) Removal

1. Remove the side cover (R). See **“Side Cover (R) Removal”** on **page 4-8**, for more information.
2. Remove the IOD2 P.W.B. See **“IOD2 P.W.B. Removal”** on **page 4-28**, for more information.
3. Remove the washer, of applicable cam clutch, from the shaft.
4. Pull out the applicable cam clutch from the shaft.

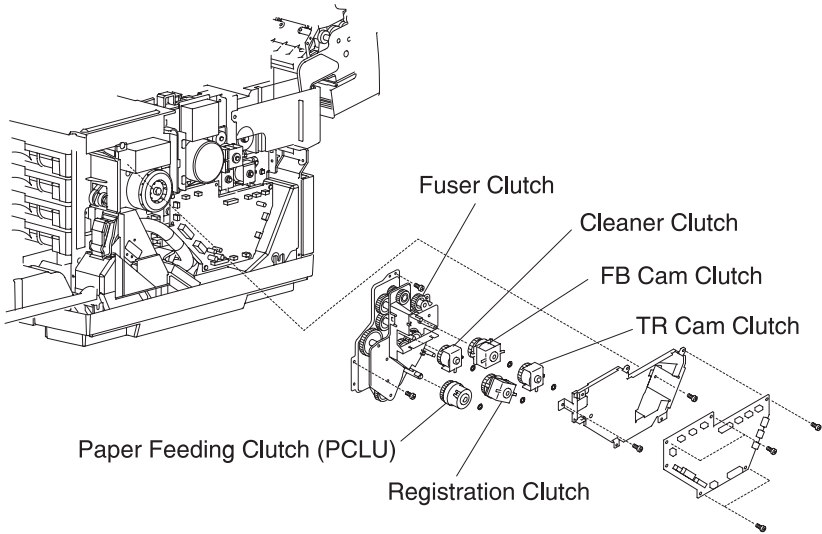

# Sensor Removals

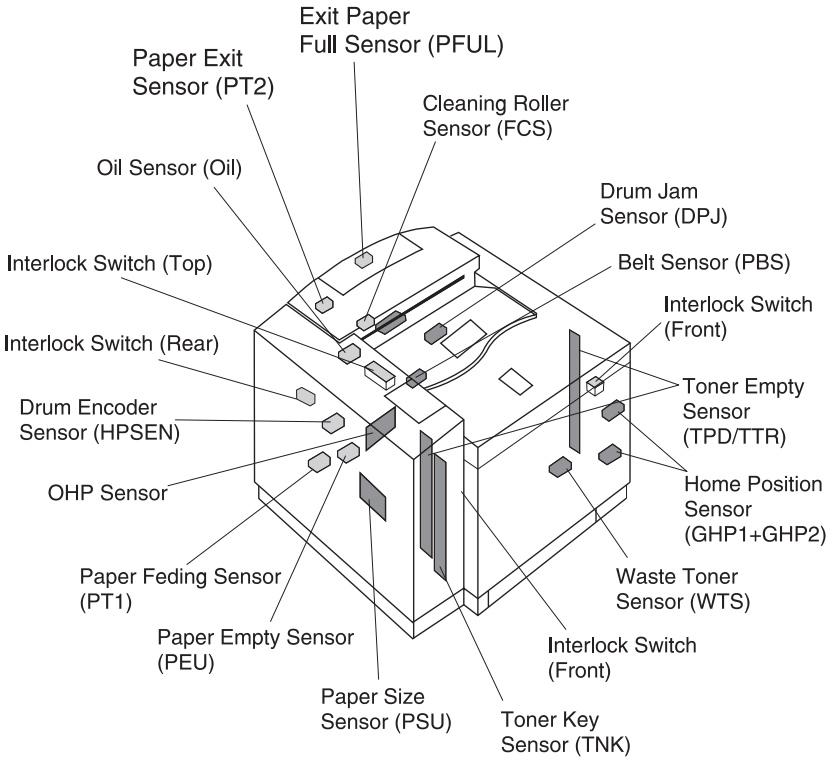



## Interlock Switch (Front) Removal

1. Remove the upper side cover (L). See **“Upper Side Cover (L) Removal” on page 4-7**, for more information.
2. Remove the top cover assembly. See **“Top Cover Assembly Removal” on page 4-12**, for more information.
3. Remove the set screws ST3x6 (4) from shield cover (upper) and remove shield cover (upper).
4. Remove the set screw BT3X8 (1) from the switch base.
5. Disconnect the interlock switch connector.
6. Remove the switch from the switch base.

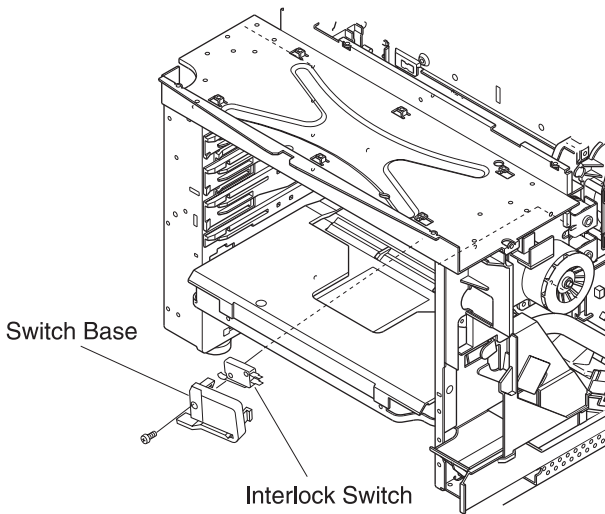

## Interlock Switch (Top) Removal

1. Remove the controller fan. See **“Control Fan (3) (CTFAN) Removal”** on page 4-47, for more information.
2. Remove the switch from the controller fan case.

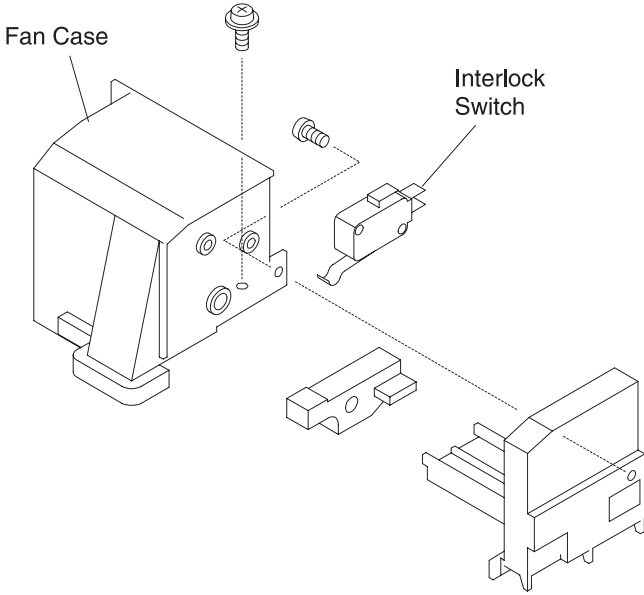

## Interlock Switch (Rear) Removal

1. Remove the side cover (L). See **“Side Cover (L) Removal” on page 4-10**, for more information.
2. Remove the high voltage power supply unit. See **“High Voltage Power Supply Unit (HVU) Removal” on page 4-33**, for more information.
3. Remove the transfer drum. See **“Transfer Drum Removal” on page 4-81**, for more information.
4. Remove the transfer unit. See **“Transfer Unit Removal” on page 4-79**, for more information.
5. Remove the set screws ST3X6 (2) from the transfer electrode base.
6. Remove the transfer electrode base from the frame.
7. Disconnect all harness connectors to the interlock switch.

8. Remove the interlock switch from the transfer electrode base.

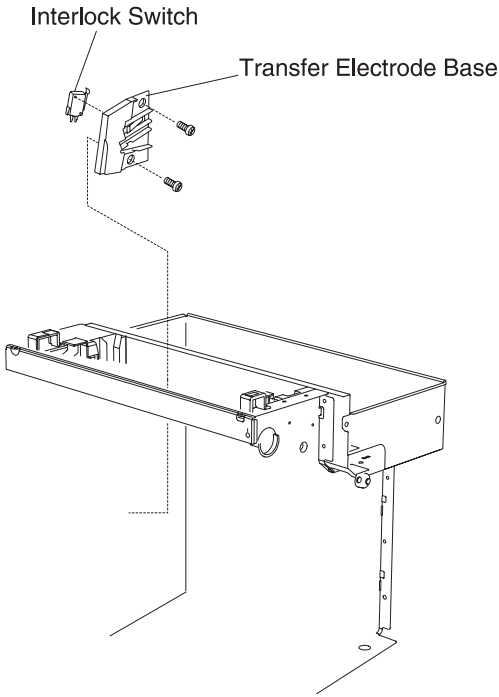

**CAUTION:** Since the interlock switch is an important safety feature in this printer, confirm the interlock switch operates normally.

## Paper Sensor (Paper Feeding Sensor PT1) Removal

1. Remove the transfer unit. See **“Transfer Unit Removal”** on **page 4-79**, for more information.
2. Remove the set screws ST3X2 (2) from the paper guide (L).
3. Remove the paper guide (L).
4. Remove the set screws ST3X6 (2) from the paper guide (UL) assembly.
5. Unlock the paper feeding sensor from the rear side of the hole through which the paper guide (UL) has been removed.
6. Disconnect all connectors to the paper feeding sensor.
7. Remove the paper feeding sensor from the feeder stay.

**WARNING:** Do not remove the separator pad mounting bracket as it is positioned at the factory and cannot be adjusted.

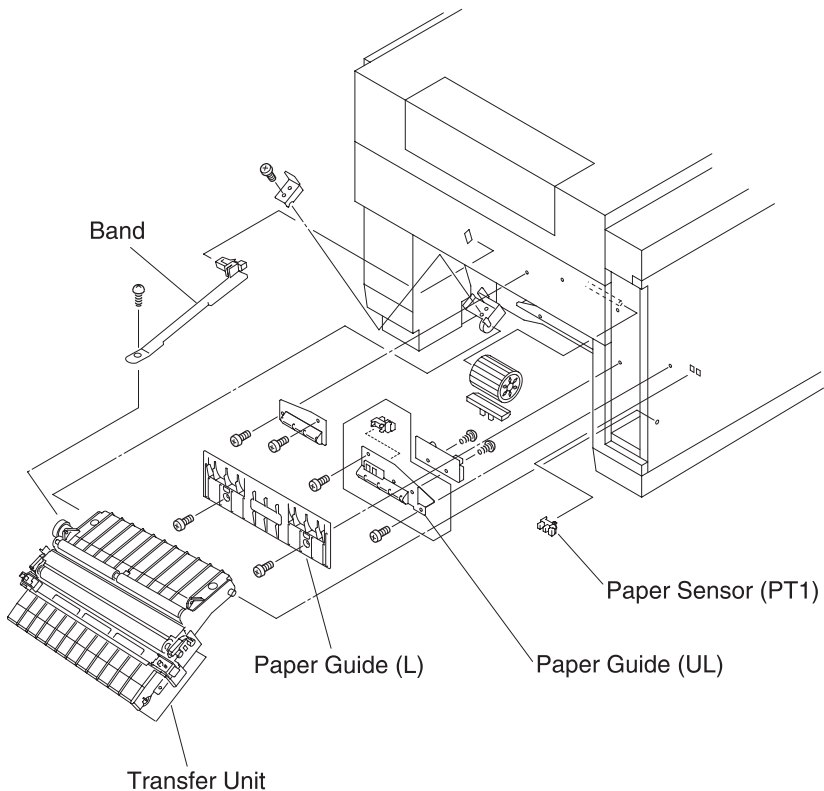

## Paper Exit Sensor (PT2) Removal

1. Remove the paper exit unit 2. See **“Paper Exit Unit / Paper Exit Roller Removal”** on page 4-86, for more information.
2. Remove the set screws ST3X6 (7) from the base assembly.
3. Remove the paper sensor base from paper exit frame.
4. Disconnect the harness connected to the paper exit sensor (PT2).
5. Remove the paper exit sensor from the paper exit sensor base.

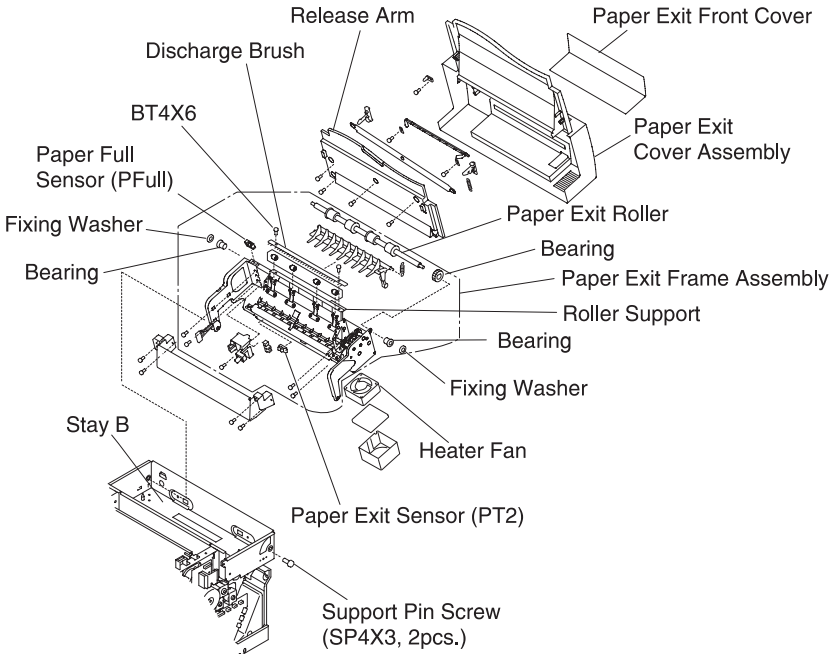

## Paper Empty Sensor (PEU) / OHP Sensor (OHP) Removal

1. Remove the transfer unit. See **“Transfer Unit Removal” on page 4-79**, for more information.
2. Remove the set screws ST3X6 (2) from the paper guide (L).
3. Remove the paper guide (L).
4. Remove the set screws ST3X6 (2) from the paper guide assembly (UL).
5. Remove the connector from the sensor.
6. Remove the paper guide assembly (UL).
7. Remove the paper empty sensor (PEU) from the paper guide assembly (UL), or remove the set screws BT3X8 (2) from the OHP sensor (OHP) and the paper guide assembly (UL).
8. Remove the OHP sensor (OHP).

**WARNING:** Do not remove the separator pad mounting bracket as it is positioned at the factory and cannot be adjusted.

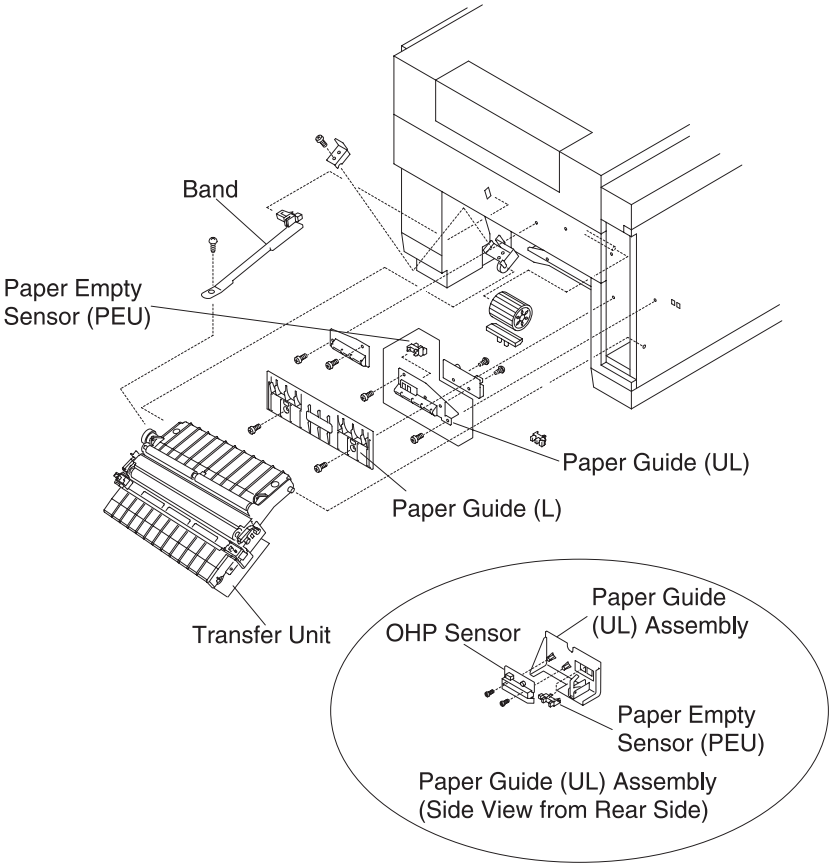



## Paper Size Sensor (PSU) Removal

1. Remove the side cover (L). See **“Side Cover (L) Removal”** on **page 4-10**, for more information.
2. Remove the power supply unit. See **“Power Supply Unit (Low Voltage Power Supply - LVPS) Removal”** on **page 4-30**, for more information.
3. Remove the set screws BT3X8 (2) of the paper cassette guide (L) assembly.
4. Pull the paper cassette guide toward you.
5. Remove the connector to the paper size sensor.
6. Remove the paper cassette guide (L) assembly from the frame.
7. Remove the set screws BT3X8 (2) from the paper size sensor from the cassette guide (L).

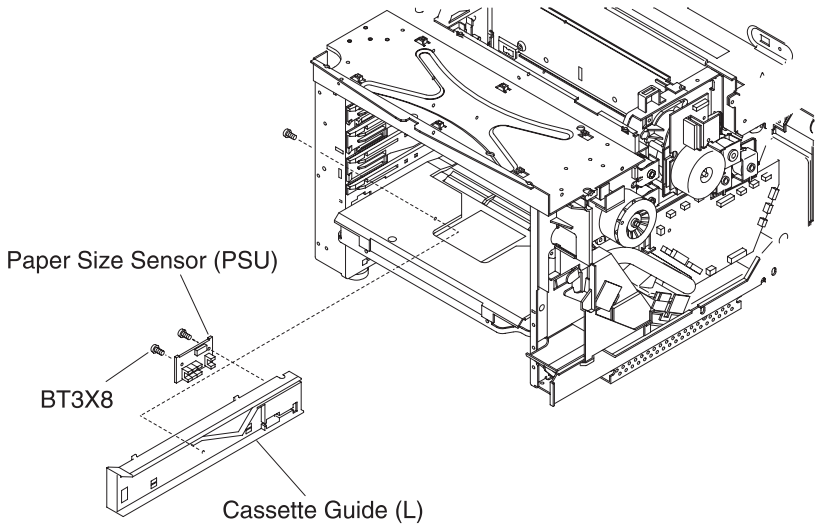

## Drum Jam Sensor (DPJ) Removal

1. Remove the fuser unit.
2. Remove the OPC belt cartridge.
3. Remove the drum cleaner.
4. Remove the transfer drum. See **“Transfer Drum Removal”** on **page 4-81**, for more information.
5. Remove the wiring harness cover Ex and cover F.
6. Disconnect the drum jam sensor.
7. Remove the drum jam sensor from the stay B.

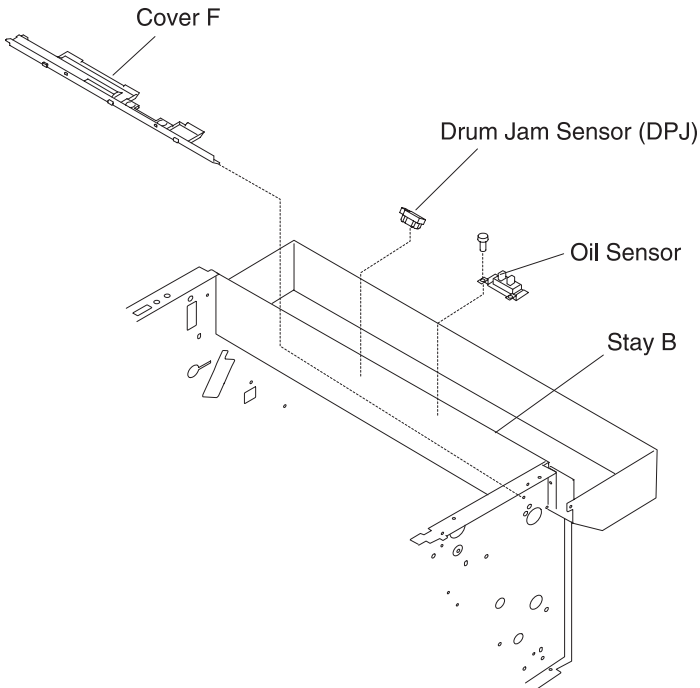

## Oil Sensor (OIL) Removal

1. Remove the fuser unit.
2. Remove the side cover (L). See **“Side Cover (L) Removal” on page 4-10**, for more information.
3. Remove the side cover (L). See **“Side F Cover (L) Removal” on page 4-11**, for more information.
4. Remove the top cover assembly. See **“Top Cover Assembly Removal” on page 4-12**, for more information.
5. Remove the controller case 'A' assembly. See **“Power Supply Unit (Low Voltage Power Supply - LVPS) Removal” on page 4-30**, for more information.
6. Disconnect the oil sensor connector.
7. Remove the set screws ST3X6 (2) from the oil sensor.
8. Remove the oil sensor.

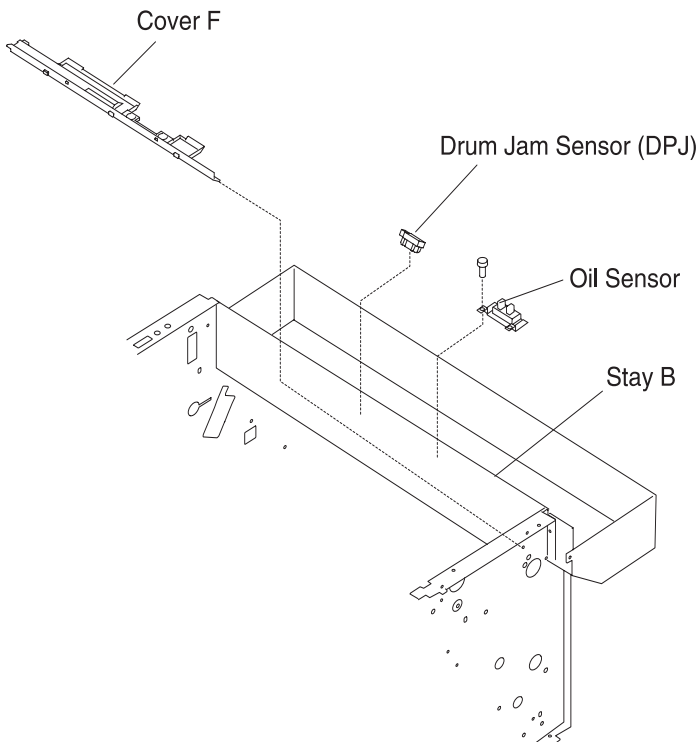

## Drum Encoder Sensor (HPSEN) Removal

1. Remove the toner cartridge.
2. Remove the OPC belt cartridge.
3. Remove the drum cleaner brush.
4. Remove the fuser unit.
5. Remove the side cover (L) 2. See **“Side Cover (L) Removal” on page 4-10**, for more information.
6. Remove the top cover assembly. See **“Top Cover Assembly Removal” on page 4-12**, for more information.
7. Remove the transfer drum. See **“Transfer Drum Removal” on page 4-81**, for more information.
8. Remove the high voltage power supply unit. See **“High Voltage Power Supply Unit (HVU) Removal” on page 4-33**, for more information.
9. Remove the sensor holder assembly from the frame (L).
10. Disconnect the encoder sensor.
11. Remove the encoder sensor from the sensor holder.

## 5024-001

**WARNING:** Do not touch the transfer drum surface with bare hands, or scratch it.

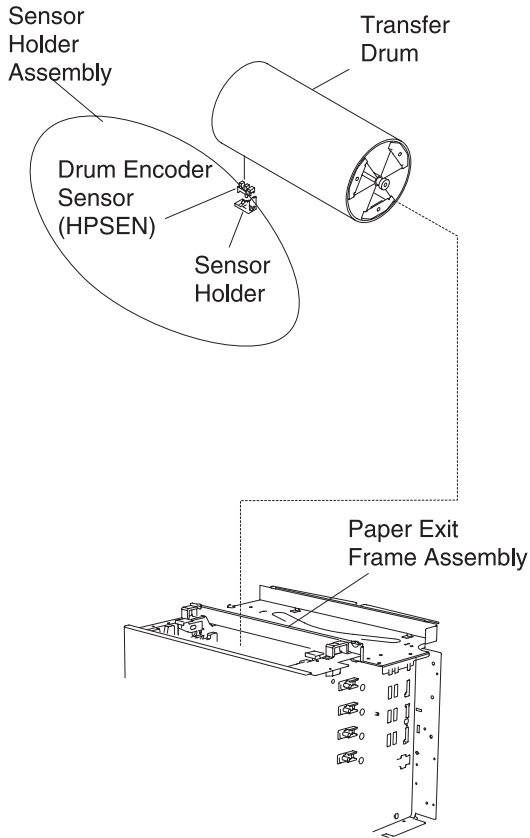

## Belt Sensor (PBS) Removal

1. Remove the toner cartridges.
2. Remove the OPC belt cartridge.
3. Remove the top cover assembly. See **“Top Cover Assembly Removal” on page 4-12**, for more information.
4. Remove cleaner cover. See **“Cleaner Cover Removal” on page 4-21**, for more information.
5. Remove drum cleaner.
6. Remove the fixing screws ST3X6 (2) from stay A base.
7. Disconnect the belt sensor.
8. Remove the belt sensor, from the stay A assembly.

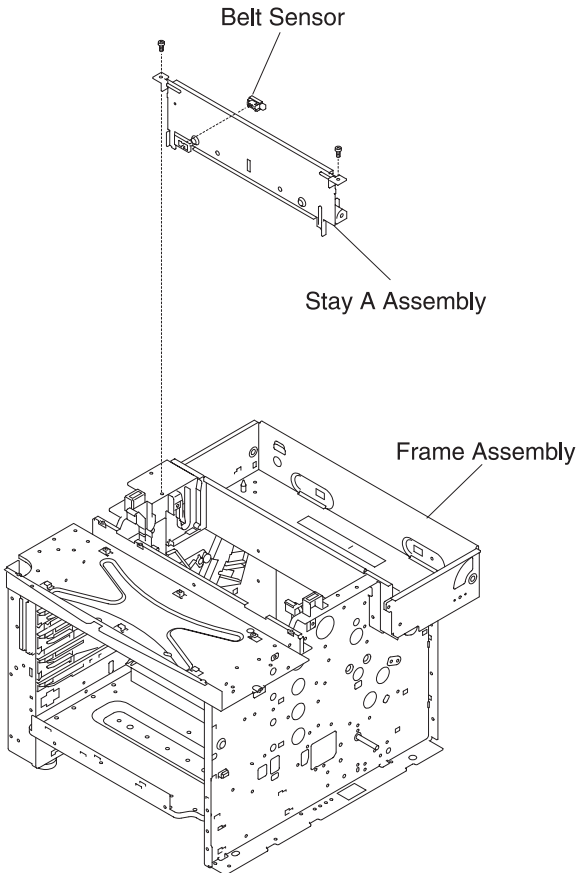

## Waste Toner Sensor (TBLE/TBFL) (Waste Toner Holder Assembly) Removal

1. Remove the side cover (R) 2. See **“Side Cover (R) Removal” on page 4-8**, for more information.
2. Remove the bottom cover (R) 2. See **“Base Cover (R) Removal” on page 4-18**, for more information.
3. Remove the cover F.
4. Remove the screw ST3X6 (1) from the base frame (R).
5. Remove the screw ST3X6 from the bottle holder.
6. Remove the waste toner holder assembly 2. See **“Developer Motor (DM) Removal” on page 4-41**, for more information.

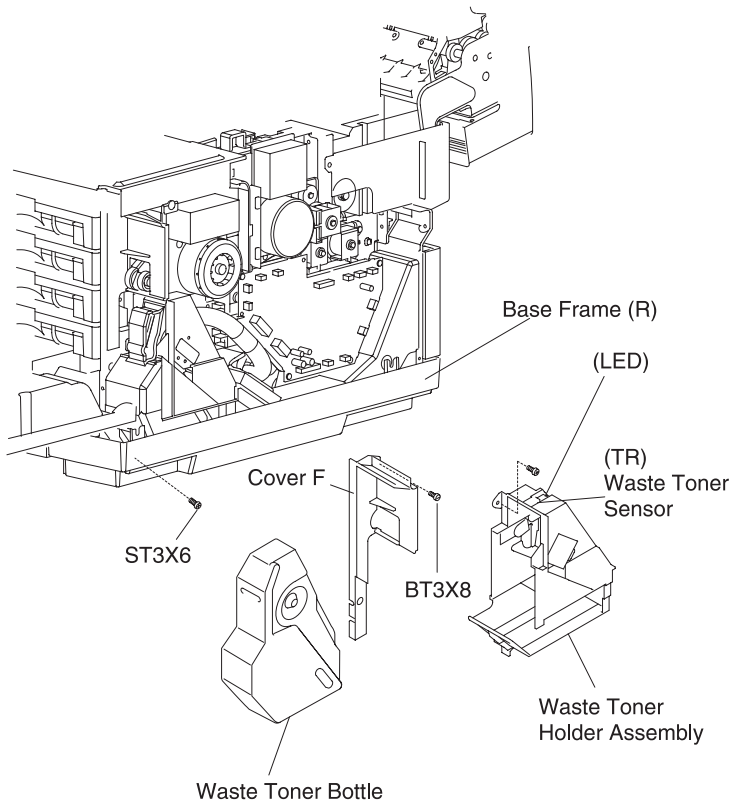

## Toner Sensor Assembly (TPD) / (TTR) Removal

### (TPD)

1. Remove the side cover (R). See **“Side Cover (R) Removal” on page 4-8**, for more information.
2. Remove the developer drive unit. See **“Developer Drive Unit Removal” on page 4-42**, for more information.
3. Remove the waste toner holder assembly. See **“Waste Toner Sensor (TBLE/TBFL) (Waste Toner Holder Assembly) Removal” on page 4-73**, for more information.
4. Remove the set screws ST3X6 (3) from the toner sensor P.W.B.
5. Disconnect the toner sensor P.W.B.

### (TTR)

1. Remove the side cover (L). See **“Side Cover (L) Removal” on page 4-10**, for more information.
2. Remove the high voltage unit (HVU). See **“High Voltage Power Supply Unit (HVU) Removal” on page 4-33**, for more information.
3. Remove the power supply unit (LVPS). See **“Power Supply Unit (Low Voltage Power Supply - LVPS) Removal” on page 4-30**, for more information.
4. Remove the set screws ST3X6 (3) of toner sensor P.W.B.



**5024-001**

5. Remove the toner sensor P.W.B.

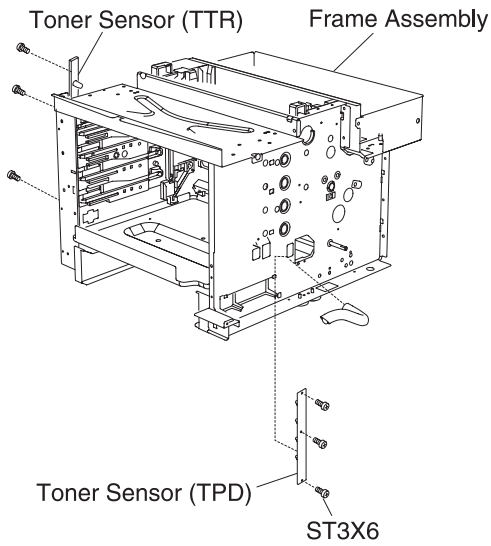

## Cleaning Roller Sensor (FCS) Removal

1. Open the paper exit unit.
2. Remove the set screw ST3X6 (1) from the FCS case assembly.
3. Remove the FCS sensor case assembly from the paper exit unit.
4. Remove the connector, from the FCS sensor.
5. Remove the FCS sensor from the paper exit sensor case.

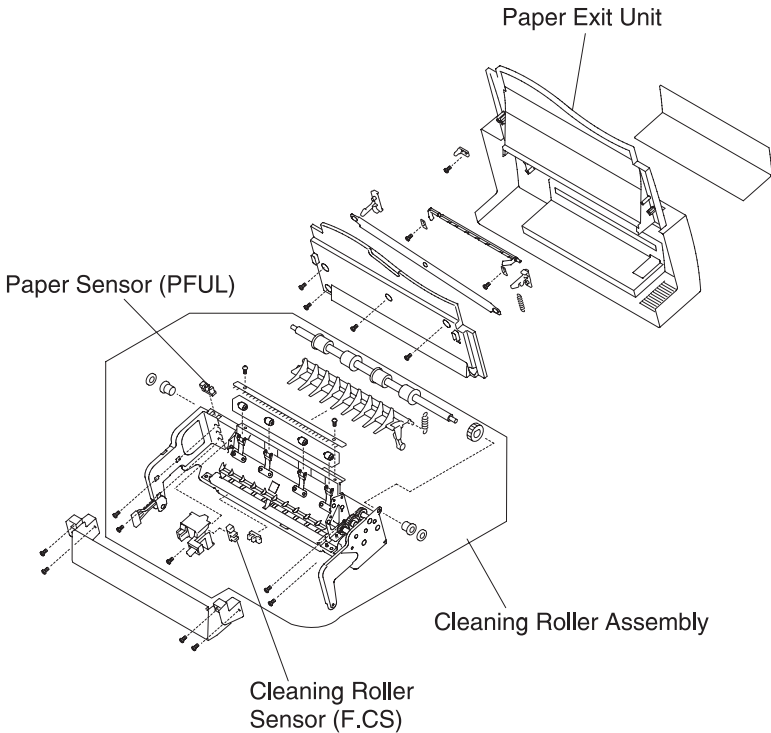

## Paper Full Sensor (PFUL) Removal

1. Remove the paper exit unit See **“Paper Exit Unit / Paper Exit Roller Removal”** on page 4-86, for more information.
2. Disconnect the harness from the paper full sensor.
3. Remove the paper full sensor.

### Notes:

- Unhook the installation base and remove the switch.
- Close the paper exit cover.

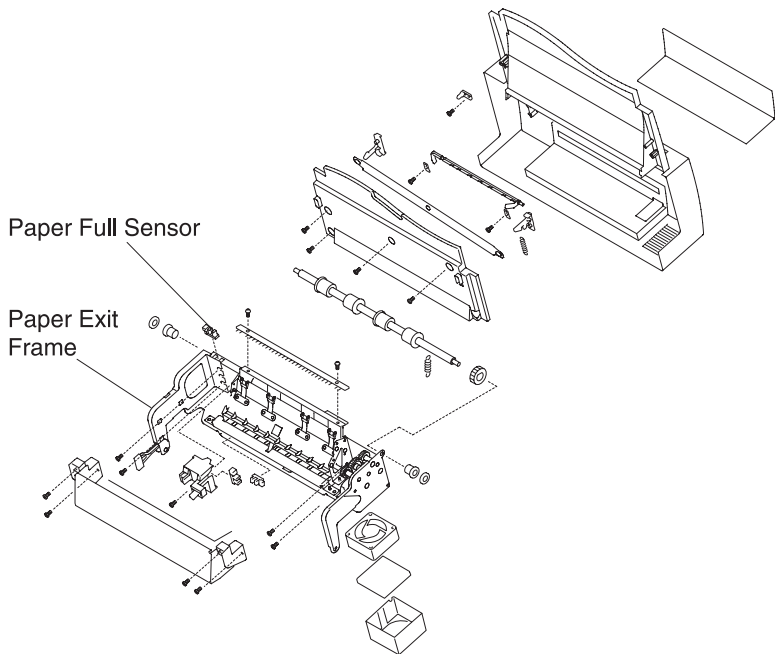

## Toner Key Sensor (TNK) Removal

1. Remove the upper side cover (L). See **“Upper Side Cover (L) Removal” on page 4-7**, for more information.
2. Remove the side cover (L). See **“Side Cover (L) Removal” on page 4-10**, for more information.
3. Remove top cover assembly. See **“Top Cover Assembly Removal” on page 4-12**, for more information.
4. Remove the shield case A assembly. See **“Power Supply Unit (Low Voltage Power Supply - LVPS) Removal” on page 4-30**, for more information.
5. Remove the shield cover (upper).
6. Disconnect DCN15 from the IOD1.
7. Remove the set screws ST3X6 (2) from the toner key sensor assembly.
8. Remove the toner key sensor from the toner key sensor assembly.

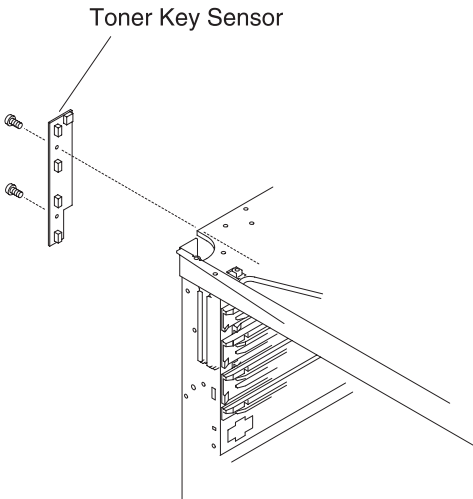

---

## Transfer Unit (Rollers and Drum) Removal

### Transfer Unit Removal

1. Open the transfer unit.
2. Remove the set screw BT4X10 (1) from the retainer band on the transfer unit.
3. Remove the set screw ST3X6 (1) from the fixing metal stop on the transfer unit.
4. Remove the shaft from the frame installation hole.
  - a. Lifting the left side, remove the shaft from the hole.
  - b. Slide the transfer unit to the left end and undo the shaft from the right side hole.

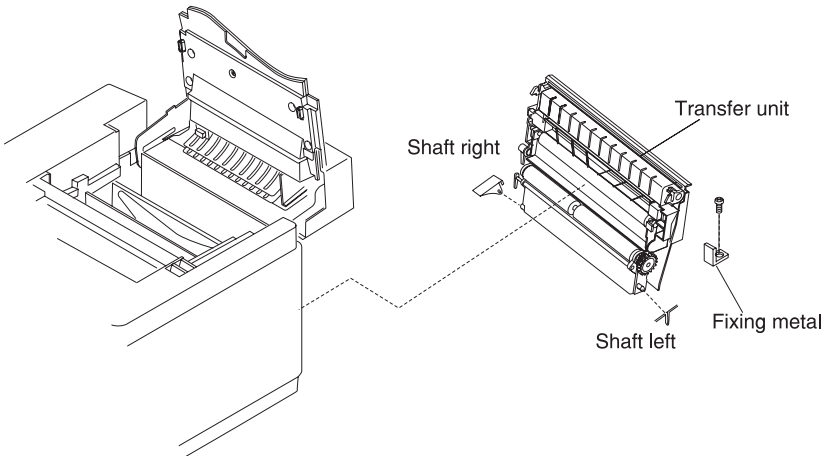

**Note:** Install the transfer unit with the fixing metal stop.

## Registration Roller Removal

1. Remove the transfer unit. See **“Transfer Unit Removal”** on page 4-79, for more information.
2. Remove the fixing washer from the roller on both sides.
3. Remove the gear from the shaft.
4. Remove the bearing on both sides.
5. Remove the registration roller from the transfer unit frame.

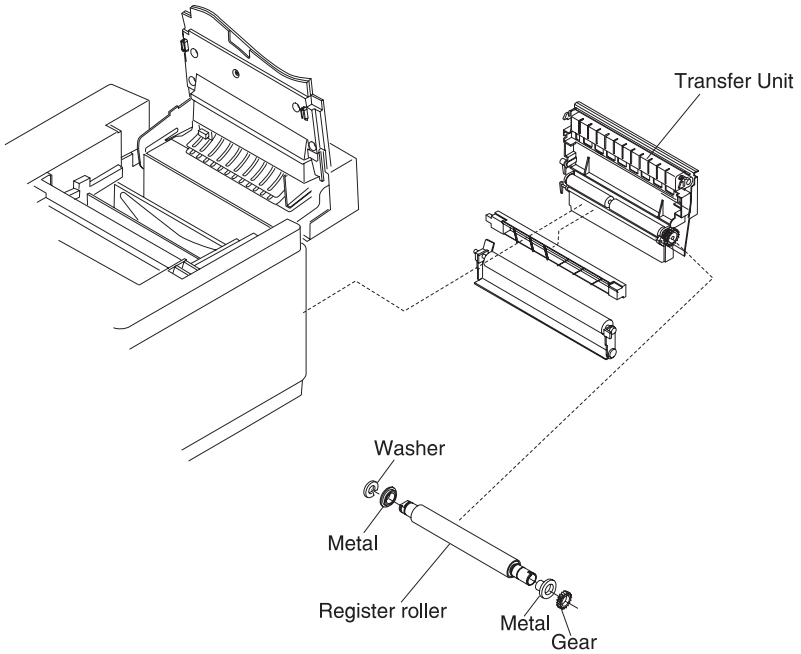

## Transfer Drum Removal

1. Remove the toner cartridges.
2. Remove the belt cartridge.
3. Remove the fuser unit.
4. Remove the cleaner cover.
5. Remove the drum cleaner.
6. Open the transfer unit.
7. Remove the top cover assembly. See **“Top Cover Assembly Removal” on page 4-12**, for more information.
8. Remove the set screws ST4X6 (2) from stay 'A'.
9. Remove the stay 'A' assembly.

**WARNING:** Wrap the transfer drum surface with paper so the transfer drum will not be scratched. (The transfer drum, as a maintenance part, has a protective sheet.)

10. Pull the transfer drum, from the top side, and remove it from the shaft support.
11. Pull up and remove the transfer drum from the top.

**5024-001**

**WARNING:** Do not touch the transfer drum surface with bare hands, or scratch it.

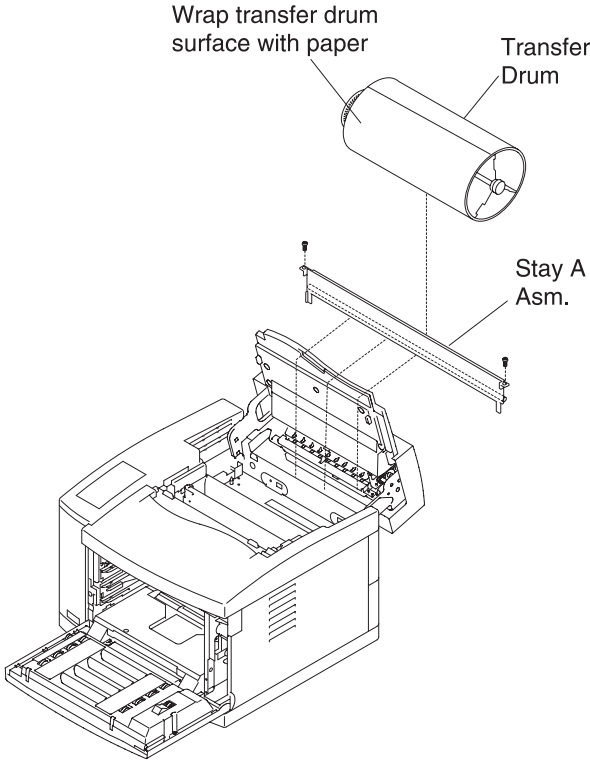



## Paper Feed Roller / Separator Pad Removal

1. Remove the paper feeding cassette.
2. Remove the transfer unit 2. See **“Transfer Unit Removal”** on **page 4-79**, for more information.
3. Remove the set screws ST3X6 (2) from the paper guide (L).
4. Remove the paper guide (L).
5. Remove the set screws ST3X6 (2) from the paper guide (UL).
6. Remove the paper guide (UL).
7. Slide the paper feeding roller to the right side, remove it from the shaft.
8. Pull up and remove the separator pad.

### WARNING:

1. Do not touch the surface of the paper feed roller and separator pad.
2. Do not remove the separator pad mounting bracket as it is positioned at the factory and cannot be adjusted.

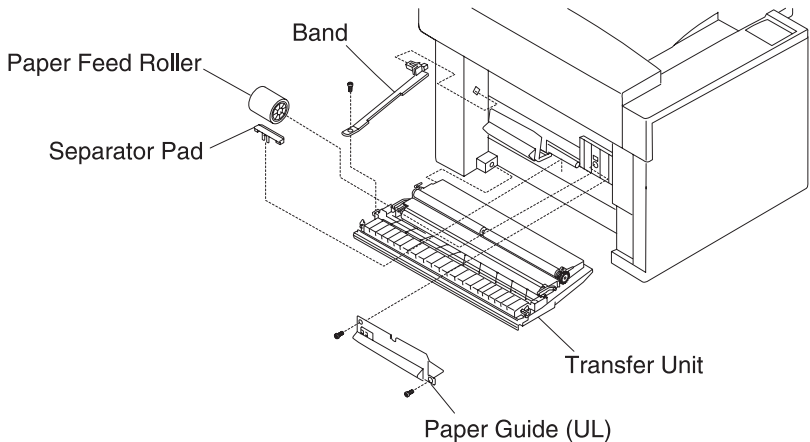

## Front Cover Unit Removal

1. Open the front cover.
2. Remove the cover C. See **“Optical Unit (Printhead Scanner Motor Assembly) Removal” on page 4-44**, for more information.
3. Remove the front cover. See **“Front Cover Removal” on page 4-22**, for more information.
4. Disconnect the bottom of the hinge support from the front cover unit.
5. Remove the set screws BT4X10 (4) from the front inner cover.
6. Remove the front inner cover.
7. Disconnect the harness connector (1) from the front cover unit.
8. Remove the fixing screw ST3X6 (1) from the front cover unit hinge support.
9. Remove the hinge support from the frame.
10. Remove the fixing screws ST3X6 (6) from the front cover unit support (3 each on the left and right side).
11. Remove the front cover unit from the frame.

### CAUTION:

- When removing the hinge from the front cover unit, watch for a spring rebound.
- Hold the fixture and remove the hook from the frame.

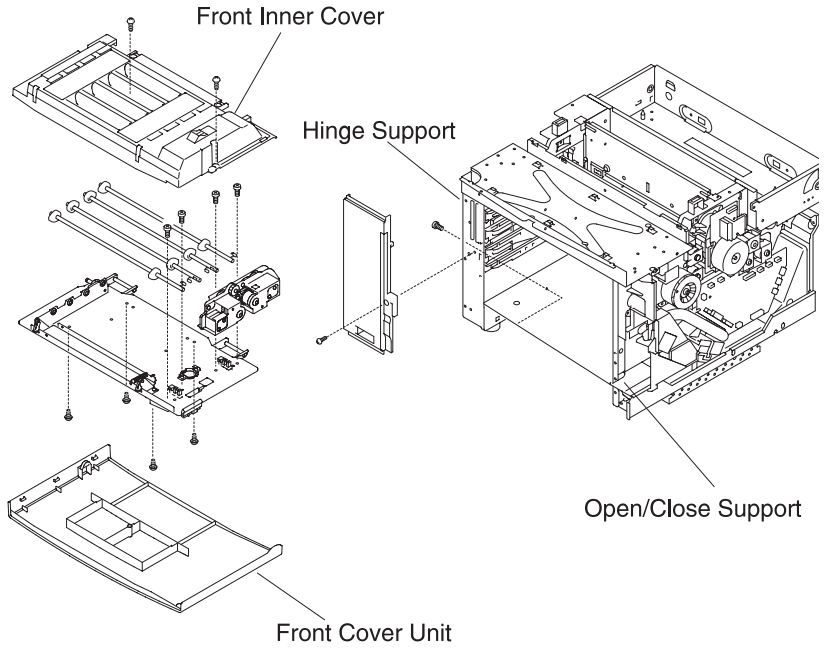

**Notes:**

1. Hook the front cover unit support through the hole on the engine side.
2. Fix the support, from the rear side with the fixing screws (3, left and right side), with the front cover unit closed.
3. Open the front cover unit and install the hinge support to the frame.
4. Tighten the remaining screws (2 each left and right side) to the front cover unit support.
5. Perform the reverse removal steps.

## Paper Exit Unit / Paper Exit Roller Removal

1. Remove the side cover (R) and (L). See **“Side Cover (R) Removal” on page 4-8** and **“Side Cover (L) Removal” on page 4-10**, for more information.
2. Remove the rear cover and rear cover (U). See **“Rear Cover Removal” on page 4-16** and **“Rear Cover (U) Removal” on page 4-17**, for more information.
3. Push paper exit harness cover (located in left side of stay B) toward rear of printer until the paper exit harness cover releases from the frame, exposing the paper exit cable connector.
4. Remove paper exit harness cover.
5. Disconnect the harness connector from the paper exit unit.
6. Remove controller board from printer.
7. Remove the set screw ST3X6 (1) from the shield cover B. See **“Main Engine (MCTL P.W.B.) Board Removal” on page 4-24**, for an illustration of the shield cover A and B.
8. Remove screws ST3X6 (2) from shield cover A.
9. Remove shield cover A to expose support pin.
10. Remove the support pin (left and right side) from the paper exit unit.
11. Remove the paper exit unit.
12. Remove the paper exit cover. See **“Paper Exit Cover / Paper Exit Front Cover / Paper Exit Cover (U) Removal” on page 4-13**, for more information.
13. Remove the screw BT4X6 (1) from the roller support.
14. Remove the fixing washer on the left and right side.
15. Remove the bearing on the left and right side.

16. Remove the paper exit roller from the frame.

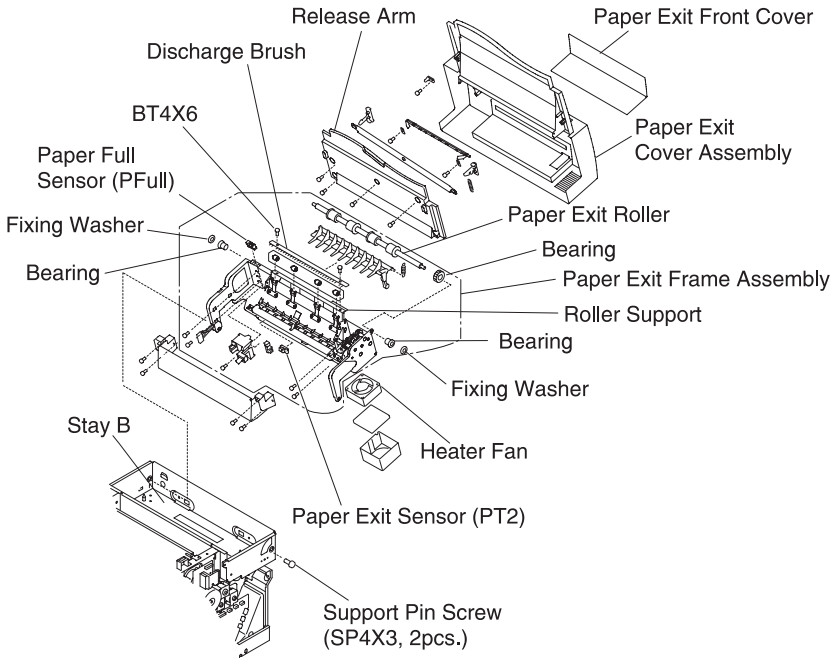

**Notes:**

1. Put the paper exit roller through the installation hole of the paper exit frame.
2. Put the bearing on the left and right through the paper exit roller shaft.
3. The bearing is keyed to fit in the frame.
4. Install the washer to the left and right side, and reinstall the roller support.

## Discharger Brush Removal

1. Remove the paper exit unit. See **“Paper Exit Unit / Paper Exit Roller Removal” on page 4-86**, for more information.
2. Remove the paper exit front cover. See **“Paper Exit Cover / Paper Exit Front Cover / Paper Exit Cover (U) Removal” on page 4-13**, for more information.
3. Remove the paper exit cover. See **“Paper Exit Unit / Paper Exit Roller Removal” on page 4-86**, for more information.
4. Remove the fixing screws BT4X8 (2) from the discharger brush.
5. Remove the discharger brush from the paper exit frame assembly.

**WARNING:** Do not deform the fur brush of the discharger brush.

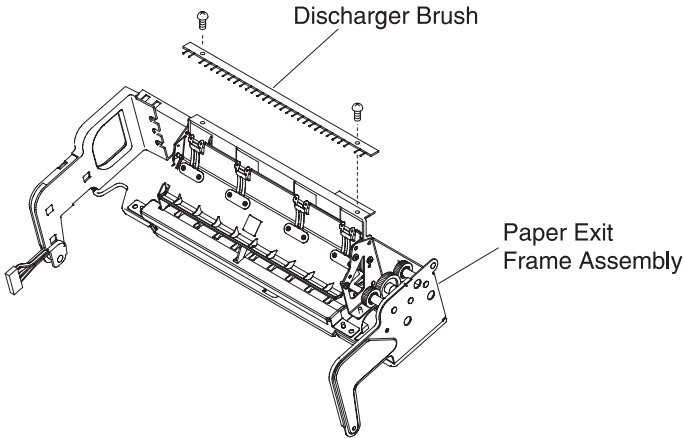

## Waste Toner Feeder (U) (Stay 'A' Assembly) Removal

1. Remove the OPC belt cartridge.
2. Remove the toner cartridges.
3. Remove the drum cleaner.
4. Remove the side upper cover (L). See **“Upper Side Cover (L) Removal” on page 4-7**, for more information.
5. Remove the top cover assembly. See **“Top Cover Assembly Removal” on page 4-12**, for more information.
6. Remove the set screws ST4X6 (2) from stay 'A'.
7. Pull up the stay 'A' assembly along the guide.
8. Remove the belt sensor (PBS) from the stay 'A' assembly.

### WARNING:

- Do not touch or scratch the transfer drum.
- Do not deform the sealing mylar of the waste toner feeder D.

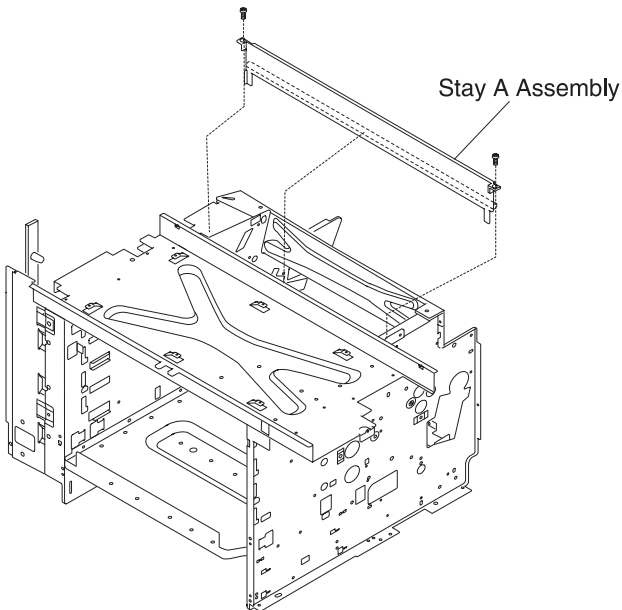

## Fuser Connector Removal

1. Remove the fuser unit. See **“Fuser Unit Removal”** on **page 4-93**, for more information.
2. Remove the side cover (L). See **“Side Cover (L) Removal”** on **page 4-10**, for more information.
3. Remove the shield case A assembly. See **“Power Supply Unit (Low Voltage Power Supply - LVPS) Removal”** on **page 4-30**, for more information.
4. Remove the connector (HP/HN) from the power supply unit.
5. Remove the connector to the fuser connector (for signal).
6. Remove the set screws ST4X10 (2) from the fuser connector.
7. Remove the fuser connector.

The set screw to the fuser connector is unique.

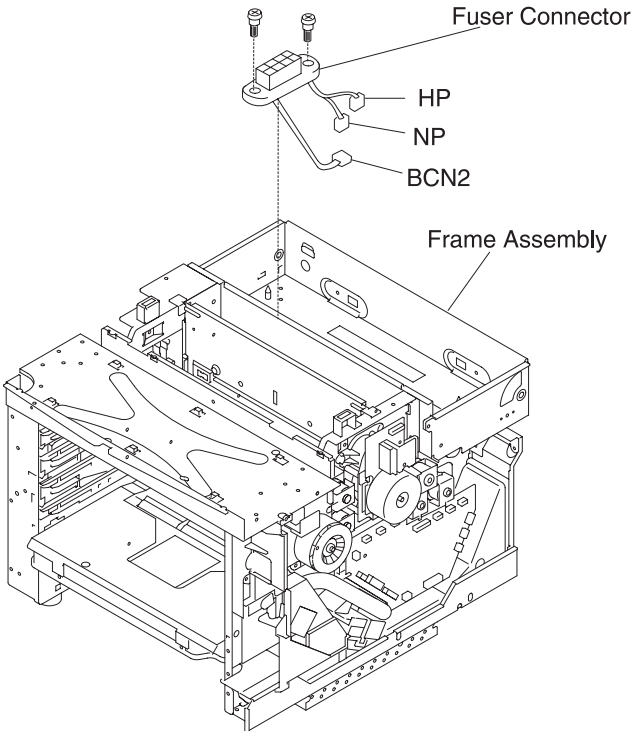



## Waste Toner Feeder (L) Removal

1. Remove the toner cartridges.
2. Remove the OPC belt cartridge.
3. Remove the side cover (R). See **“Side Cover (R) Removal” on page 4-8**, for more information.
4. Remove the IOD2 P.W.B. See **“IOD2 P.W.B. Removal” on page 4-28**, for more information.
5. Remove the base cover (R). See **“Base Cover (R) Removal” on page 4-18**, for more information.
6. Remove the set screw ST3X1 (1) from the base frame (R).
7. Remove the screw BT3x8 (1) from cover F.
8. Remove cover F.
9. Remove the screw (1) from the waste toner holder assembly.
10. Remove the waste toner holder assembly.
11. Remove the fixing screw F3X6 (1) from the ozone fan case.
12. Remove the ozone fan case.
13. Remove the set screw ST3X6 (1) from the toner drive assembly.

14. Pull out the toner drive assembly (waste toner feeder (L)).

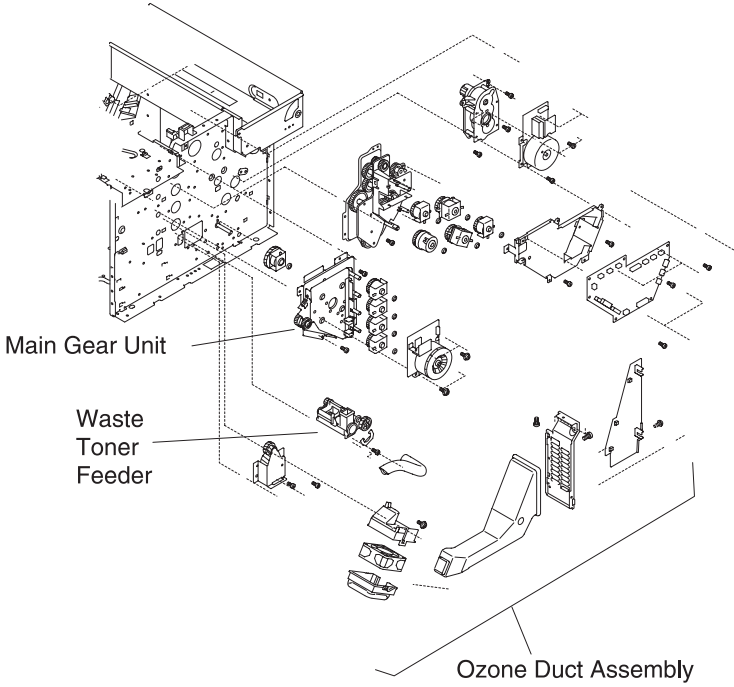

**Note:** Install the toner drive assembly to the engine frame.

## Fuser Unit Removal

### CAUTION:

1. The fuser unit consists of important parts in terms of safety. Therefore, replacement of parts or removal and maintenance work should be done at the appropriate facilities by skillful service personnel acquainted with electrical safety. After the assembling work, the product safety should be reconfirmed.
2. Since the fuser unit is very hot, make sure the fuser unit and perimeter is cooled down prior to starting the replacement of parts.
3. The fuser unit contains silicone oil. Take care not to drop, tilt, or lay the fuser unit on its side as the silicone oil could spill on the floor, which could be dangerous.

**WARNING:** When replacing the fuser unit, wait 30 minutes before copying more than 30 pages (for testing only). The fuser unit requires this amount of time for replenishment of the oil application pad inside the fuser unit. Insufficient lubrication causes paper jams and reduces the life of the fuser. Running more than 30 copies may damage the fuser unit.

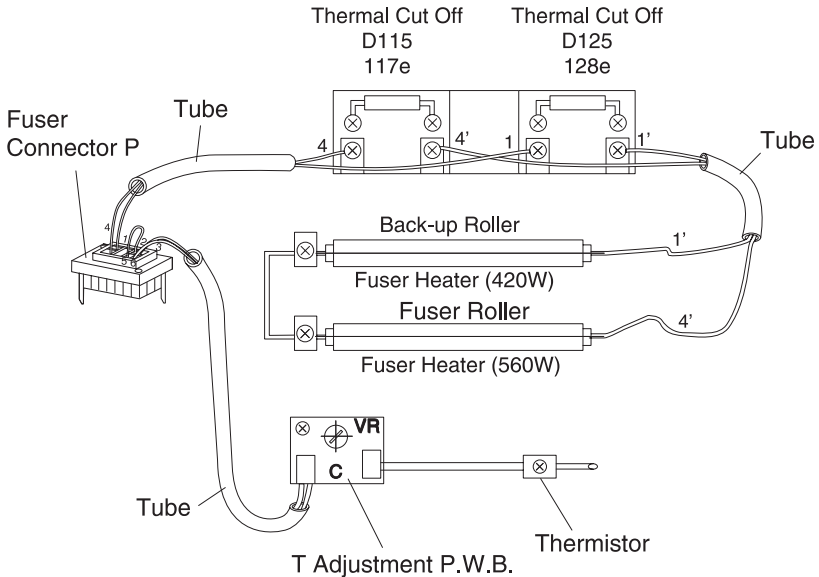

---

# Lower Feeder Unit (LFU) Removals

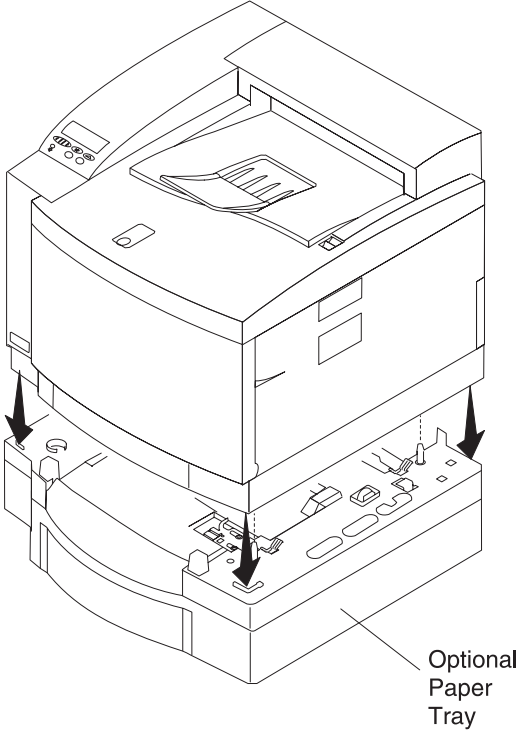

## Lower Feeder Unit Top Cover (R) Removal

1. Remove the set screws ST4X8 (2) and BT4X10 (3) from the LFU top cover (R).
2. Remove the set screw ST3X6 (1) from the GND contacts (2).
3. Remove the LFU top cover (R).

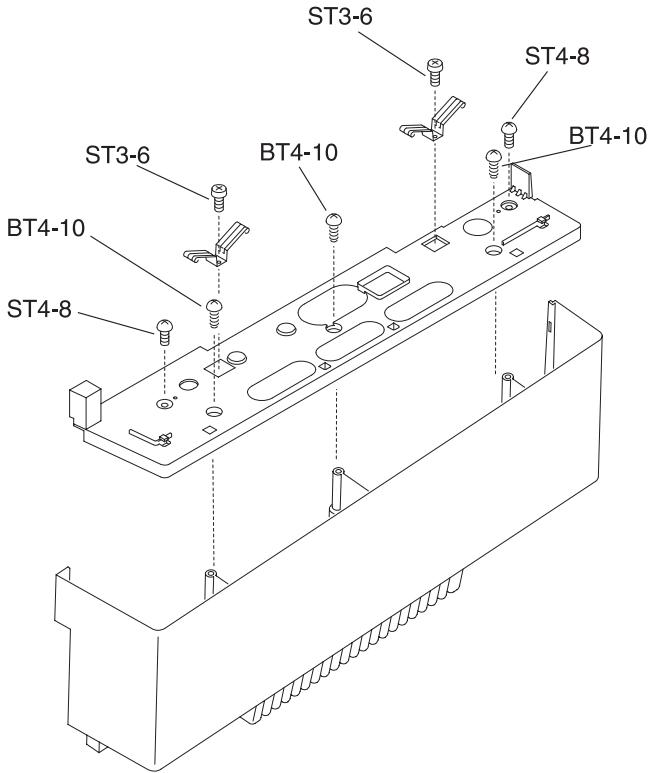

## Lower Feeder Unit Top Cover (L) Removal

1. Remove the set screws ST4X8 (2) and BT4X10 (3) in the LFU top cover (L).
2. Remove the set screw ST3X6 (1) of the GND contacts (2).
3. Remove the LFU top cover (L).

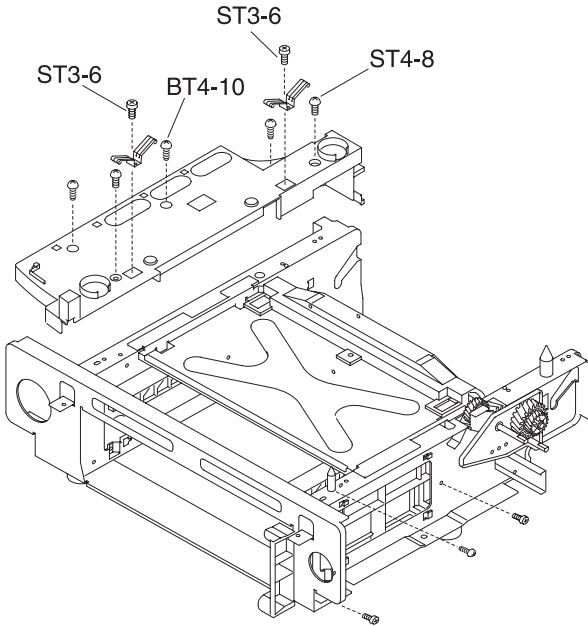

## Lower Feeder Unit Front Top Cover Removal

1. Remove the LFU top cover (R). See **“Lower Feeder Unit Top Cover (R) Removal” on page 4-95**, for more information.
2. Remove the LFU top cover (L). See **“Lower Feeder Unit Top Cover (L) Removal” on page 4-96**, for more information.
3. Remove the LFU base cover (R). See **“Lower Feeder Unit Base Cover (R) Removal” on page 4-98**, for more information.
4. Remove the LFU base cover (L). See **“Lower Feeder Unit Base Cover (L) Removal” on page 4-99**, for more information.
5. Remove the set screws ST4x10 (4) from the LFU top cover.
6. Remove the set screws BT4x8 (2) from the LFU front top cover.
7. Remove the LFU front top cover.
8. Remove the set screws BT4x10 (2) from the holding plate, and remove the holding plates.

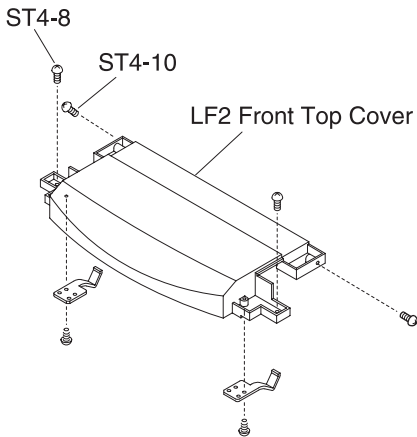

## Lower Feeder Unit Base Cover (R) Removal

1. Remove the LFU top cover (R). See “**Lower Feeder Unit Top Cover (R) Removal**” on page 4-95, for more information.
2. Remove the set screws ST4X8 (2) from the LFU base cover (R).
3. Remove the LFU base cover (R).

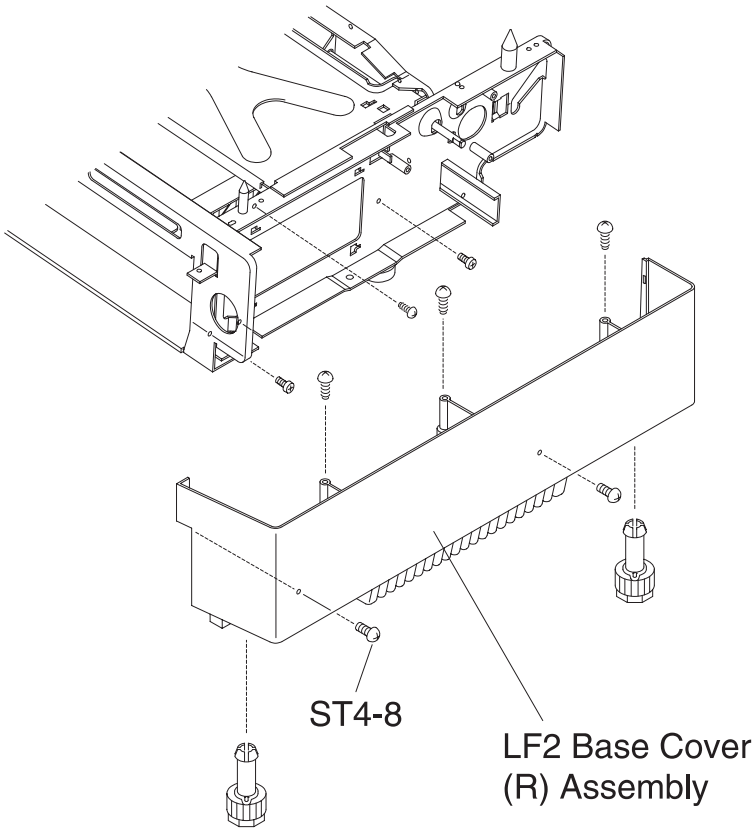



## Lower Feeder Unit Base Cover (L) Removal

1. Remove the LFU top cover (L) See **“Lower Feeder Unit Top Cover (L) Removal”** on page 4-96, for more information.
2. Remove the set screws ST4X8 (2) from the LFU base cover (L).
3. Remove the LFU base cover (L).

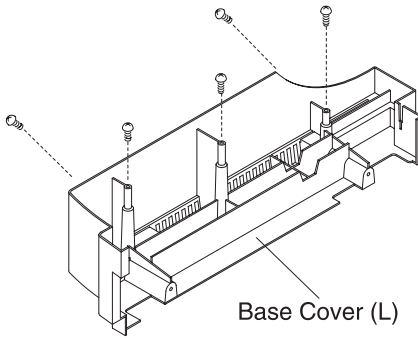

## Lower Feeder Unit Paper Sensor Removal

1. Remove the set screws ST3X6 (4) from the LFU rear cover assembly.
2. Remove the set screws ST3X6 (2) from the LFU paper guide (UL) assembly.
3. Disconnect the paper sensor.
4. Remove the paper sensor from the LFU paper guide (UL) assembly (snap in).

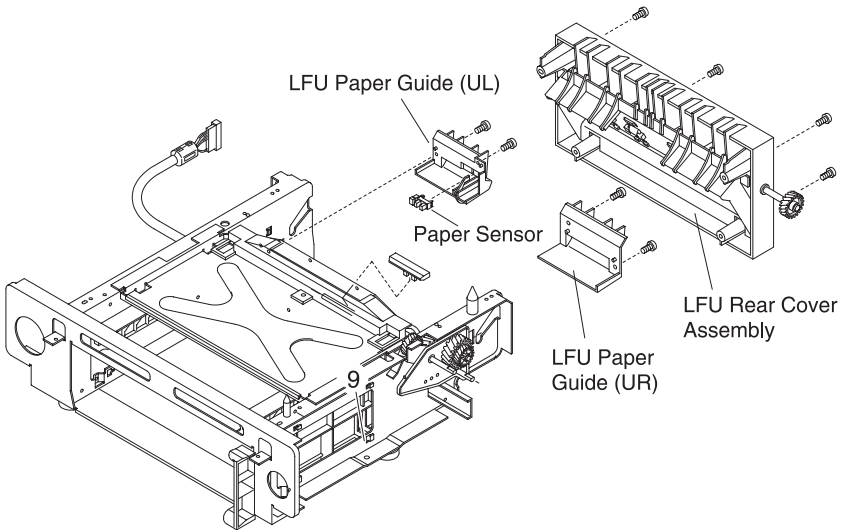

## Lower Feeder Unit Paper Size Sensor (SL-PS -A57 P.W.B. Assembly) Removal

1. Remove the LFU base cover (L). See **“Lower Feeder Unit Base Cover (L) Removal”** on page 4-99, for more information.
2. Remove the harness connector to the paper size sensor.
3. Remove the set screws BT3X8 (2) from the LFU cassette guide (L).
4. Pull the LFU cassette guide (L) toward you.
5. Remove the set screws BT3X8 (2) from the paper size sensor.
6. Remove the paper size sensor.

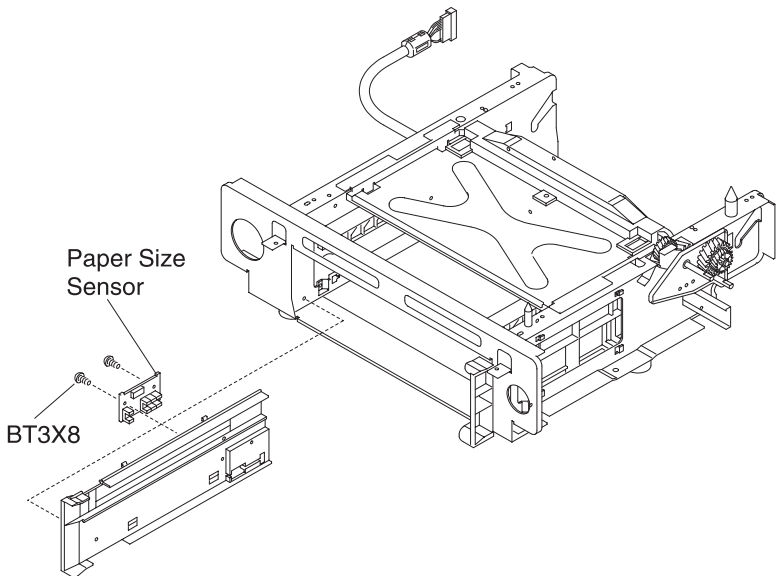

## Lower Feeder Unit Paper Feed Clutch (PKCLL) / LF Clutch (DPKCL) Removal

1. Remove the LFU top cover (R). See **“Lower Feeder Unit Top Cover (R) Removal”** on page 4-95, for more information.
2. Remove the LFU base cover (R). See **“Lower Feeder Unit Base Cover (R) Removal”** on page 4-98, for more information.
3. Remove the harness connector to the clutch.
4. Remove the paper feed clutch stopper washer and then pull the paper clutch off the shaft.
5. Remove the LFU clutch D stopper washer and then pull the LF clutch D off the shaft.

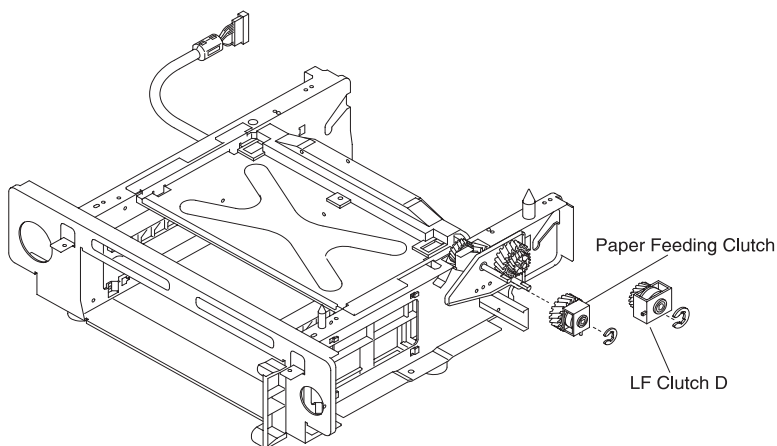

## Lower Feeder Unit Paper Feeder Rolling / Separator Pad Removal

1. Remove the LFU set screws ST3X6 (4) from the rear cover assembly.
2. Remove the LFU set screws ST3X6 (2) from the paper guide (UL) assembly.
3. Slide the paper feeder roller off the shaft.
4. Remove the separator pad.

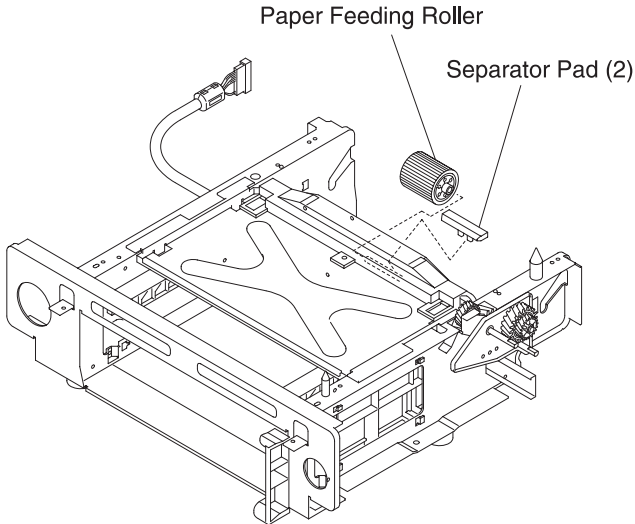

---

# Duplex Cover and Paper Guide Removals

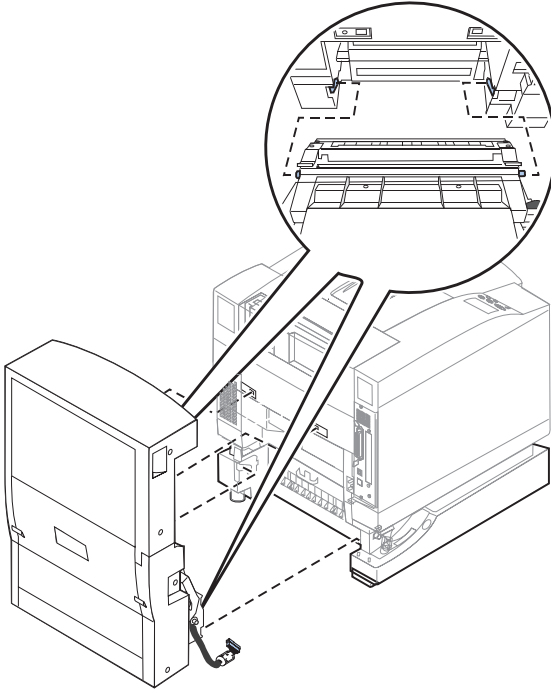

## Duplex Side Cover Low (R) Removal

1. Remove the set screws TS4x7 (2) from the side cover low (R).
2. Remove the side cover low (R) from the duplex unit.

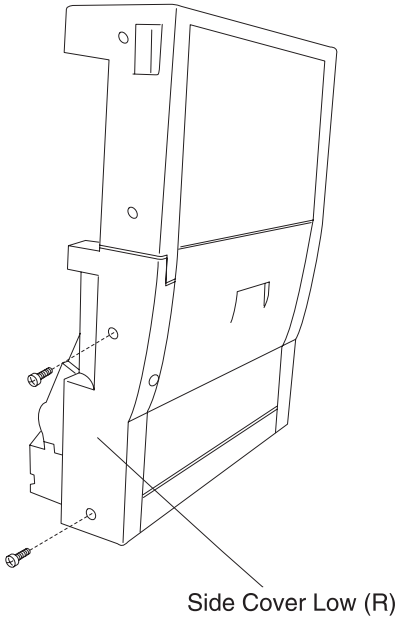

## Duplex Side Cover Low (L) Removal

1. Remove the set screws ST4X7 (2) from the side cover low (L).
2. Remove the side cover low (L) from the duplex unit.

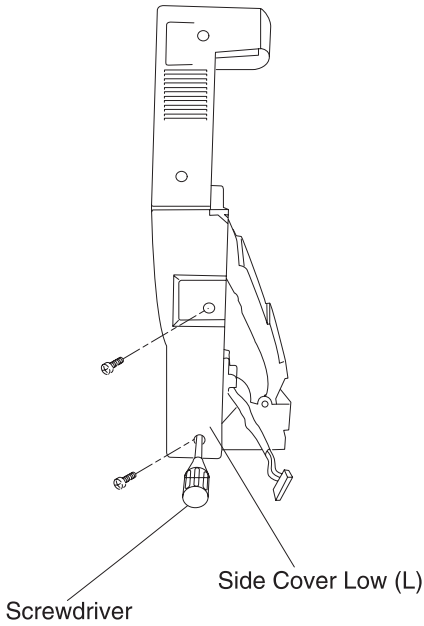



## Duplex Cover Top (R) Removal

1. Remove the set screws ST4X7 (2) from the cover top (R).
2. Remove the cover top (R) from the duplex unit.

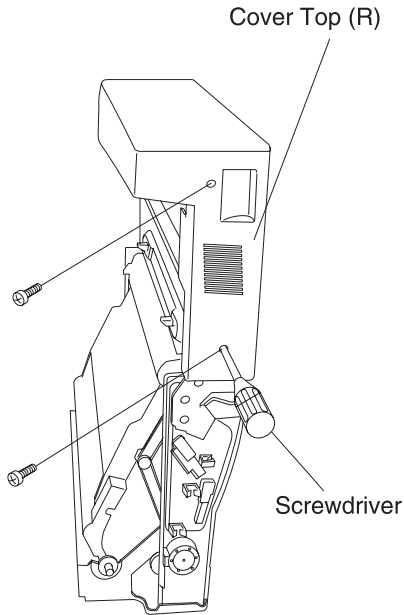

## Duplex Cover Top (L) Removal

1. Remove the side cover low (L). See, “**Duplex Side Cover Low (L) Removal**” on page 4-106, for more information.
2. Remove the set screws ST4X7 (2) from the cover top (L).
3. Remove the cover top (L) from the duplex unit.

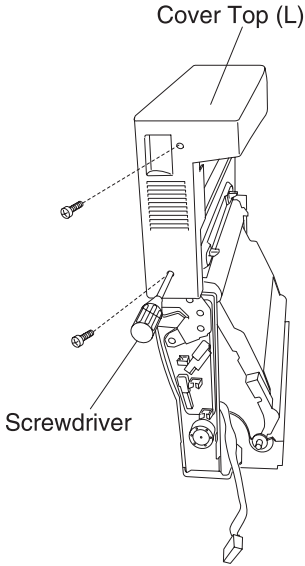

## Duplex Cover Top (B) Assembly Removal

**Note:** Includes 4 pieces of the guide rollers.

1. Remove the side cover low (R). See, “**Duplex Side Cover Low (R) Removal**” on page 4-105, for more information.
2. Remove the cover top (R). See “**Duplex Cover Top (R) Removal**” on page 4-107, for more information.
3. Remove the set screw TS3X5 (2) from the ventilator.
4. Remove the set screws TS3X8 (4) from the cover top (B) assembly.
5. Remove the cover top (B) assembly from the duplex top unit.
6. Remove the U-paper guide B from the cover top (B) assembly.

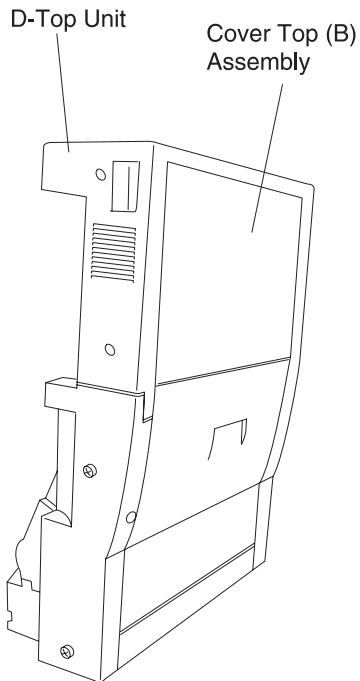

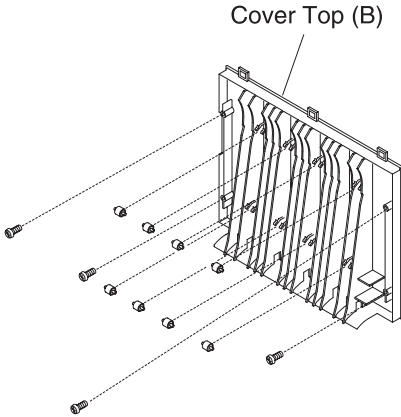
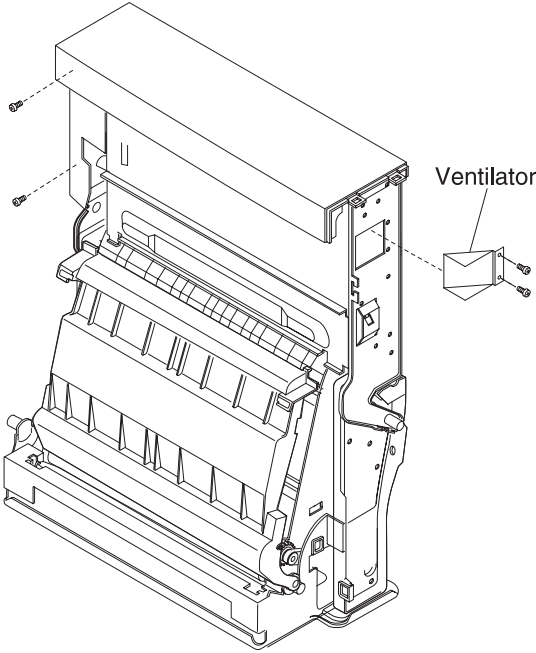

## Duplex Cover Top (C) Assembly Removal

**Note:** Includes 4 pieces of the guide rollers.

1. Remove the side cover low (R) / (L) and the cover top (R) / (L). See **“Duplex Side Cover Low (R) Removal” on page 4-105**, **“Duplex Side Cover Low (L) Removal” on page 4-106**, **“Duplex Cover Top (R) Removal” on page 4-107**, and **“Duplex Cover Top (L) Removal” on page 4-108**, for more information.
2. Remove the set screws TS3X8 (4) from the cover top (C) assembly.
3. Remove the cover top (C) assembly from the D top unit.

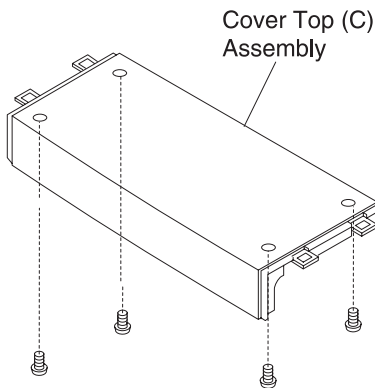
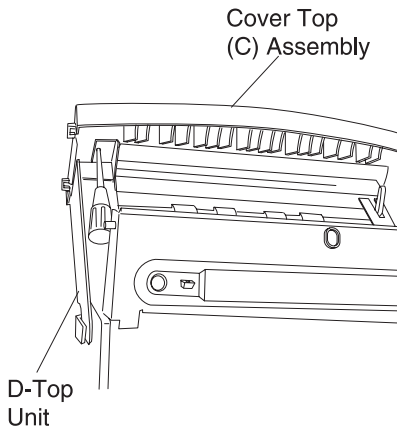

## Duplex Cover Low (B) Assembly Removal

**Note:** Includes 4 pieces (guide rollers, handle, and lock lever).

1. Open the cover low (B).
2. Remove the set screws TS3X8 (4) from the cover low (B) assembly.
3. Remove the cover low (B) assembly from the hinged metal fixture.

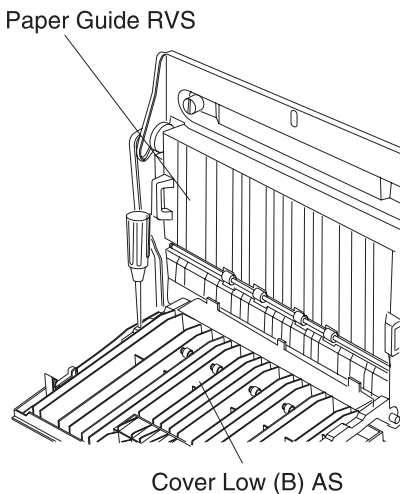
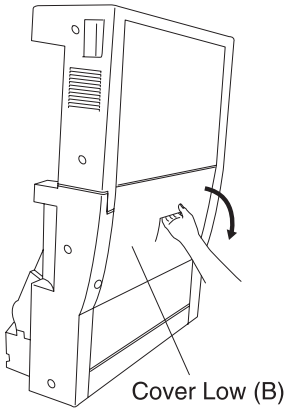

## Duplex Bottom Cover Assembly Removal

1. Remove the bottom unit. See **“Duplex Paper Top Assembly (D-Top Unit and D-Lower Unit) Removal”** on page 4-121, for more information.
2. Remove the cover low (B) assembly. See **“Duplex Cover Low (B) Assembly Removal”** on page 4-112, for more information.
3. Remove the harness cover.
4. Remove the set screws M4X6 (2) from the bottom cover.
5. Remove the harness inside the bottom cover.
6. Remove the paper guide RVS unit. See **“Duplex Paper Guide RVS Unit Removal”** on page 4-115, for more information.
7. Remove the bottom cover from the base.

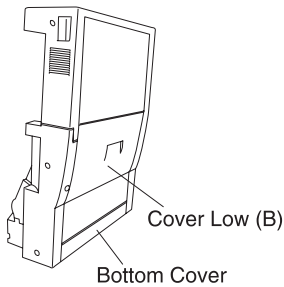

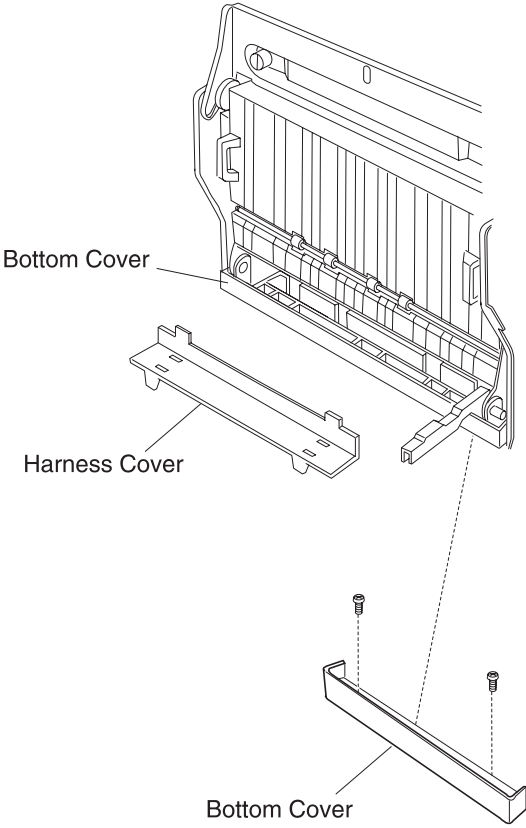



## Duplex Paper Guide RVS Unit Removal

1. Remove the cover low (R and L). See **“Duplex Side Cover Low (R) Removal” on page 4-105** and **“Duplex Side Cover Low (L) Removal” on page 4-106**, for more information.
2. Remove the paper guide RVS IN. See **“Duplex Paper Guide RVS IN Removal” on page 4-117**, for more information.
3. Remove the set screws ST3X5 (4) from the support shaft on both sides (left & right).

In this instance, the cover low (B) assembly comes off. See **“Duplex Cover Low (B) Assembly Removal” on page 4-112**, for more information.

4. Remove the support shaft from the frame.
5. Remove the retaining band from the paper guide RVS unit.
6. Remove the paper guide RVS unit from the frame.
7. Remove the harness connected to CN2 on the relay P.W.B.

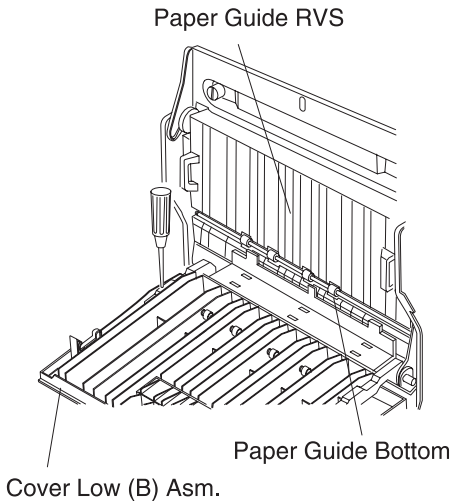

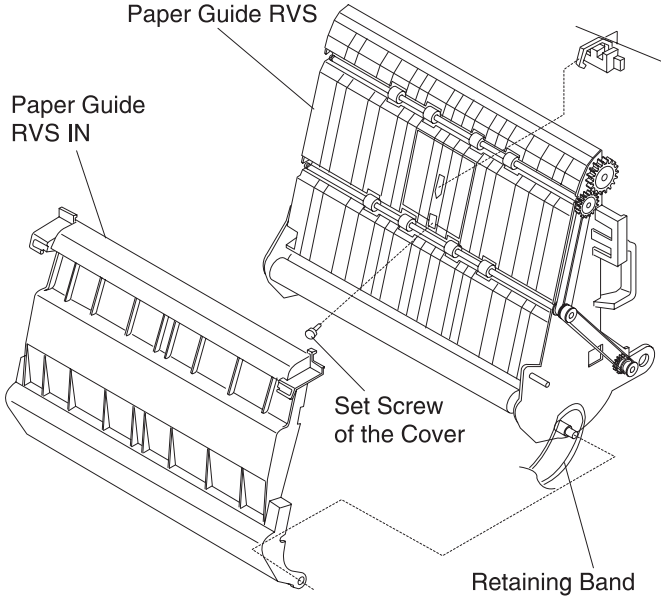

## Duplex Paper Guide RVS IN Removal

1. Open the cover low (B).
2. Open the paper guide RVS unit.
3. Remove the support part of the paper guide RVS IN from the shaft.
4. Remove the paper guide RVS IN.

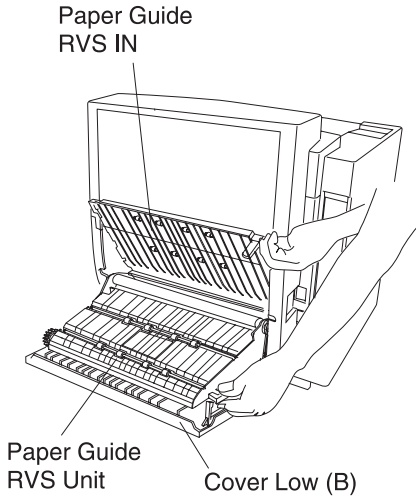

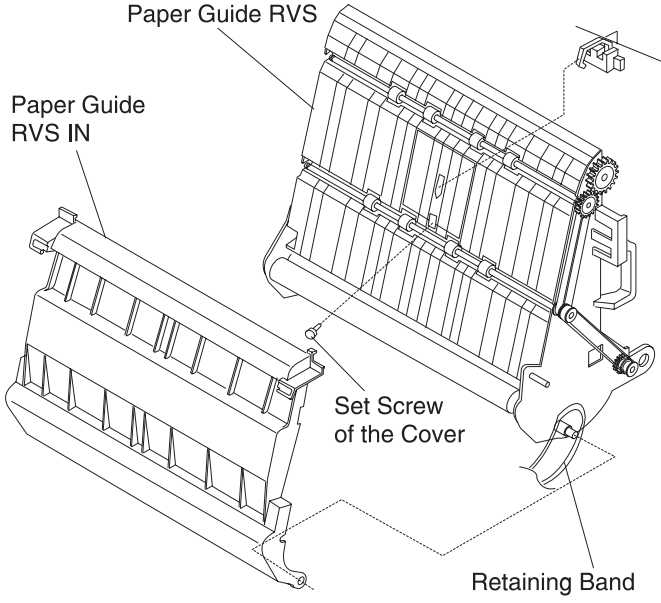

## Duplex Paper Guide Bottom Removal

1. Open the cover low (B).
2. Open the paper guide RVS unit.
3. Remove the set screw ST3X6 (1) from the paper guide bottom.
4. Remove the paper guide bottom.

5. Remove the harness connector.

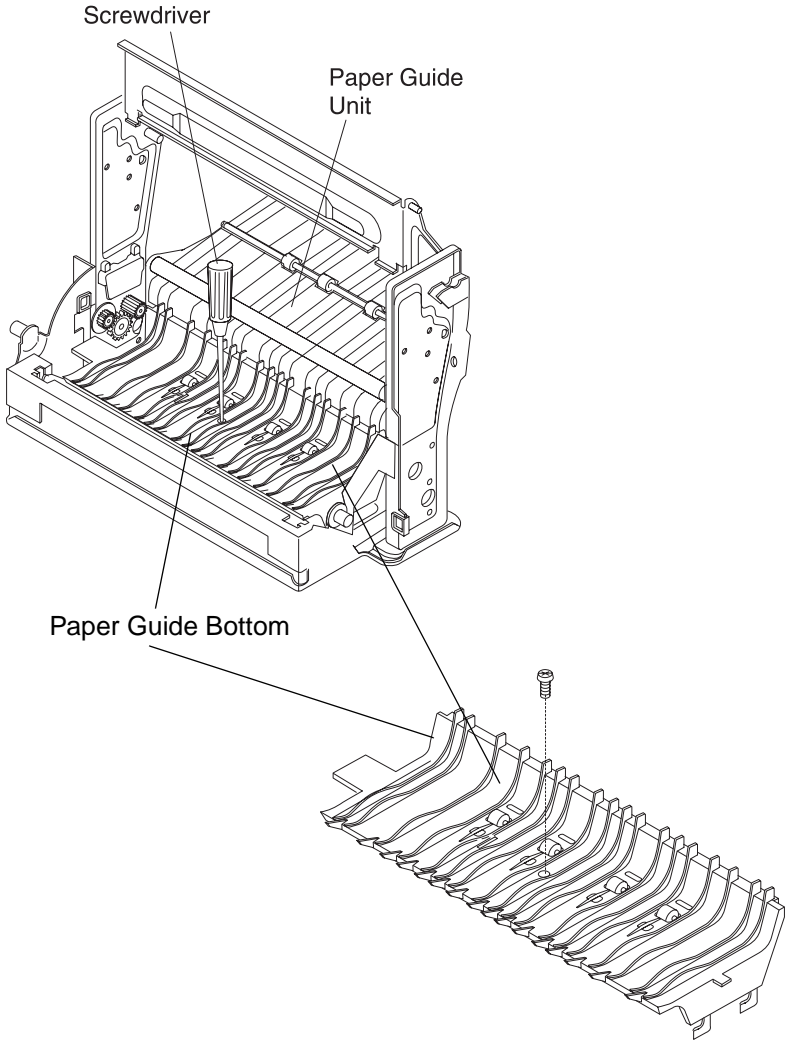

**Notes:**

1. Install the sensor (PT4) to the new paper guide bottom.
2. Install the new paper guide bottom.
3. Install the harness cover.

## Duplex Paper Top Assembly (D-Top Unit and D-Lower Unit) Removal

1. Remove cover low (R and L). See **“Duplex Side Cover Low (R) Removal” on page 4-105** and **“Duplex Side Cover Low (L) Removal” on page 4-106**, for more information.
2. Remove the solenoid connector and harness from the clamp.
3. Remove fan connector and the harness from the clamp.
4. Remove the set screws M4X8 (2) from the support pin at both sides (left & right).
5. Separate D top unit and D lower unit.

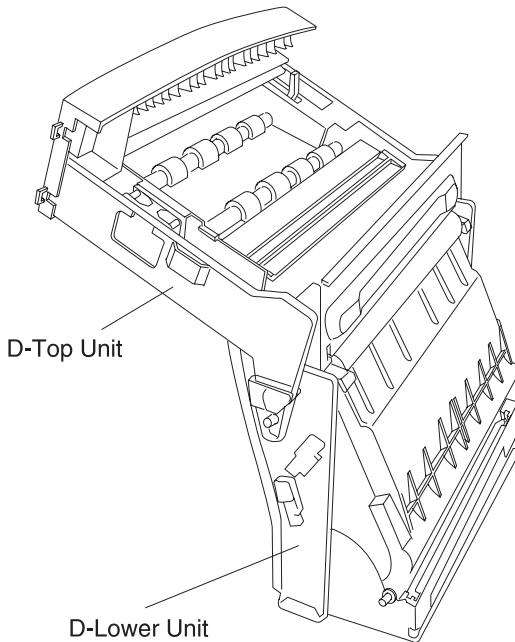

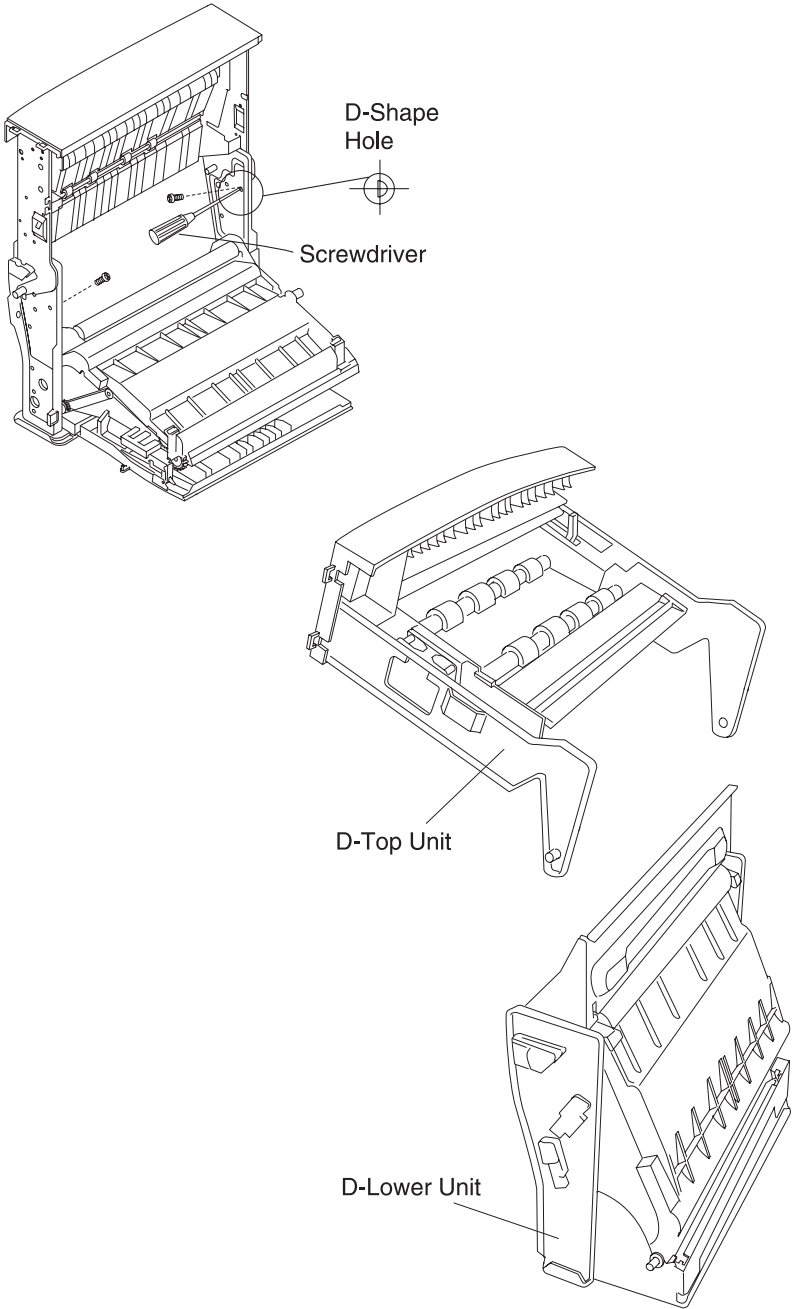



## Duplex Paper Guide Top Assembly Removal

1. Remove the cover top (R) and (L) from the D-top unit. See **“Duplex Cover Top (R) Removal” on page 4-107**, and **“Duplex Cover Top (L) Removal” on page 4-108**, for more information.
2. Remove the cover top (B) from the D-top unit. See **“Duplex Cover Top (B) Assembly Removal” on page 4-109**, for more information.
3. Remove cover top (C) from the D-top unit. See **“Duplex Cover Top (C) Assembly Removal” on page 4-111**, for more information.

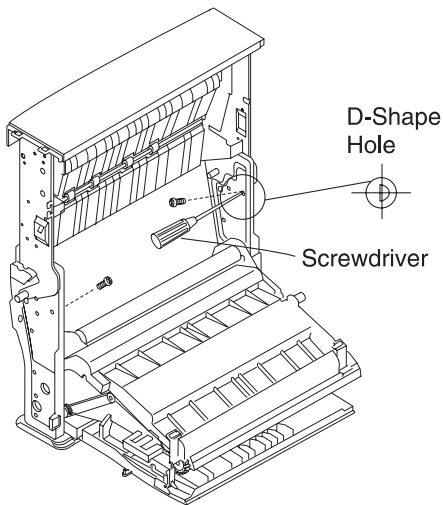

## Duplex Print P.W.B. Removal

1. Remove the paper guide bottom. See **“Duplex Paper Guide Bottom Removal”** on page 4-119, for more information.
2. Remove all the connectors to the duplex P.W.B.
3. Remove the set screws ST3X5 (4) from the duplex P.W.B.
4. Remove the duplex P.W.B.

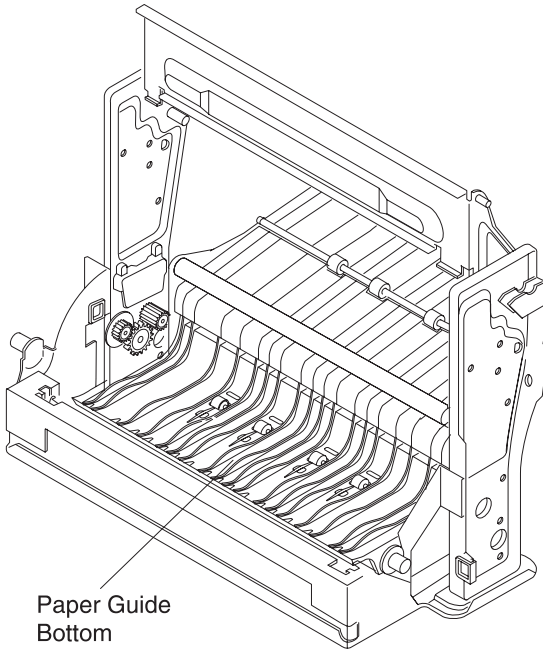

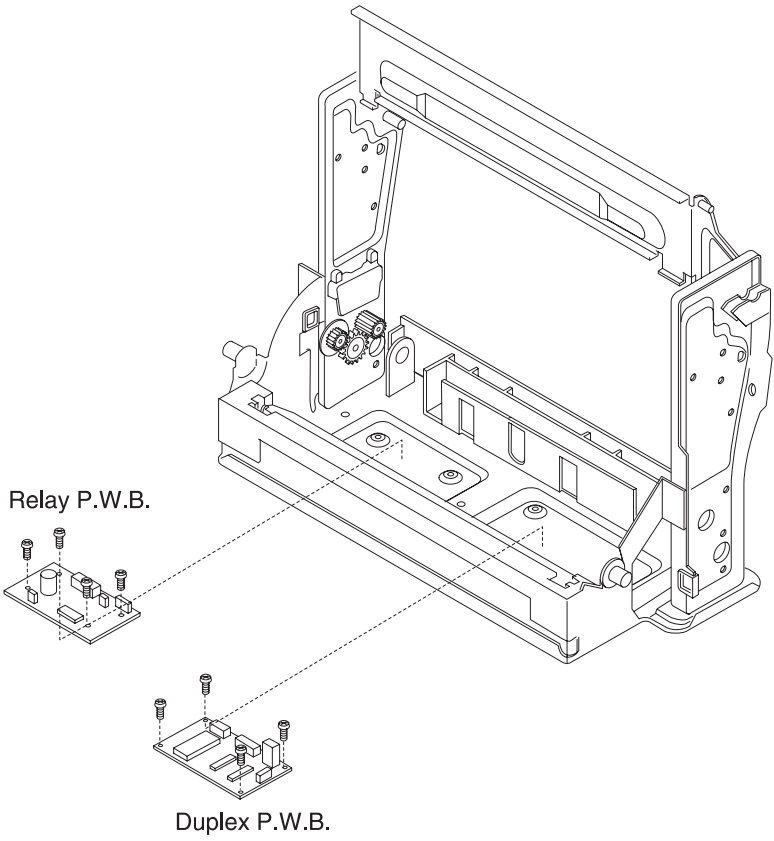

## Duplex Relay P.W.B. Removal

1. Remove the paper guide bottom. See **“Duplex Paper Guide Bottom Removal”** on page 4-119, for more information.
2. Remove the connectors from the relay P.W.B.
3. Remove the set screws ST3X5 (4) from the relay P.W.B.
4. Remove the relay P.W.B.

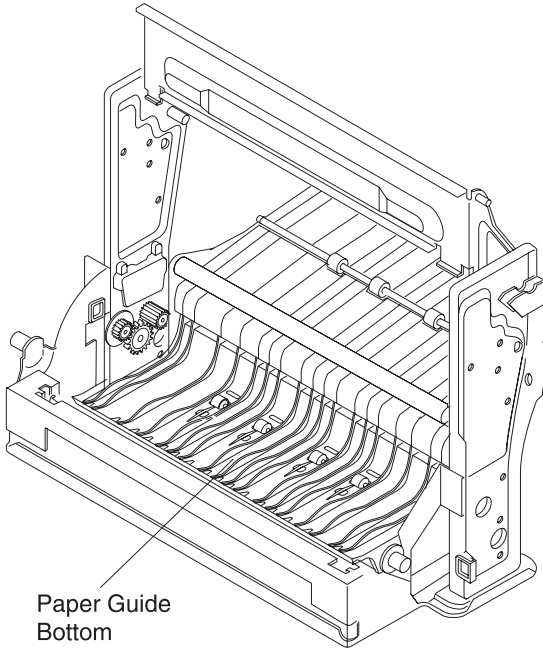

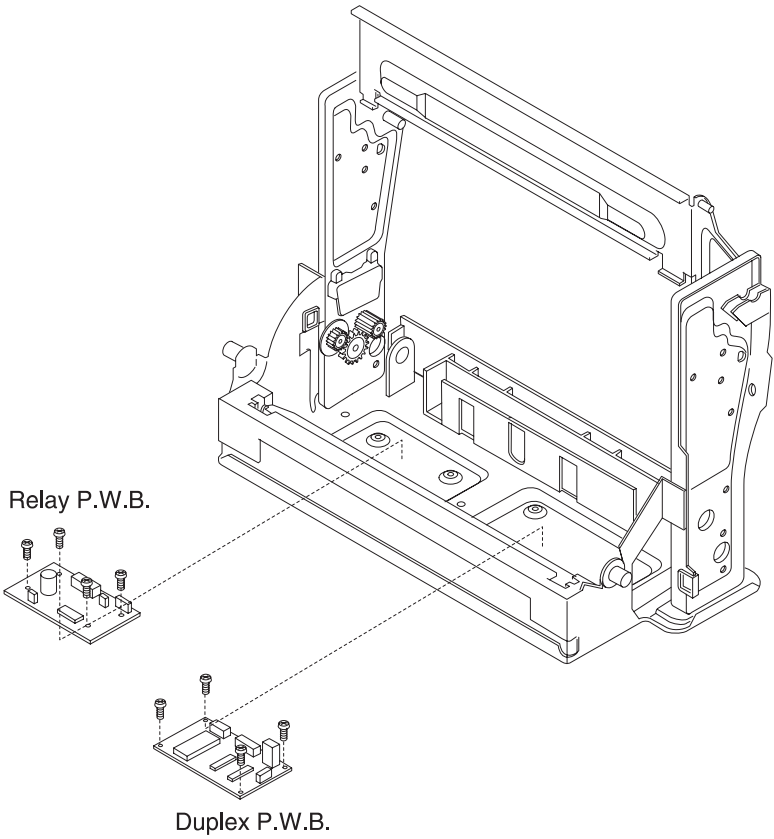

**Note:** Install the new relay P.W.B. to the base.

## Duplex Motor 1 Removal

1. Remove the paper guide bottom and the side cover low (R).  
See “**Duplex Paper Guide Bottom Removal**” on page 4-119  
and “**Duplex Side Cover Low (R) Removal**” on page 4-105,  
for more information.
2. Remove the motor harness connector CN5 from the relay  
P.W.B.
3. Remove the harness from the clamp.
4. Remove the protective cover.
5. Remove the set screws ST3X5 (2) from the motor.
6. Remove the motor from the frame.

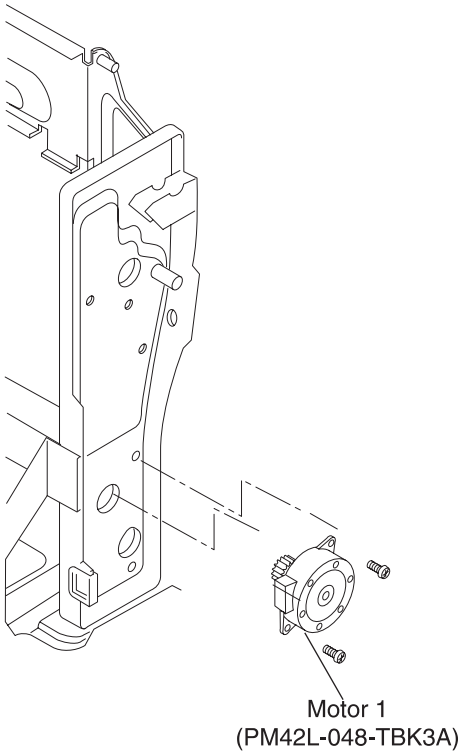

**CAUTION:** Make sure the motor harness does not contact the gear.

## Duplex Motor 2 Removal

1. Remove paper guide bottom and the side cover low (L). See **“Duplex Paper Guide Bottom Removal”** on page 4-119 and **“Duplex Side Cover Low (L) Removal”** on page 4-106, for more information.
2. Remove the motor harness connector CN7 from the relay P.W.B.
3. Remove the harness cover, and remove the harness from the clamp.
4. Remove the protective cover.
5. Remove the belt from the motor shaft.
6. Remove the set screws ST3X5 (2) from the motor.
7. Remove the motor from the frame.

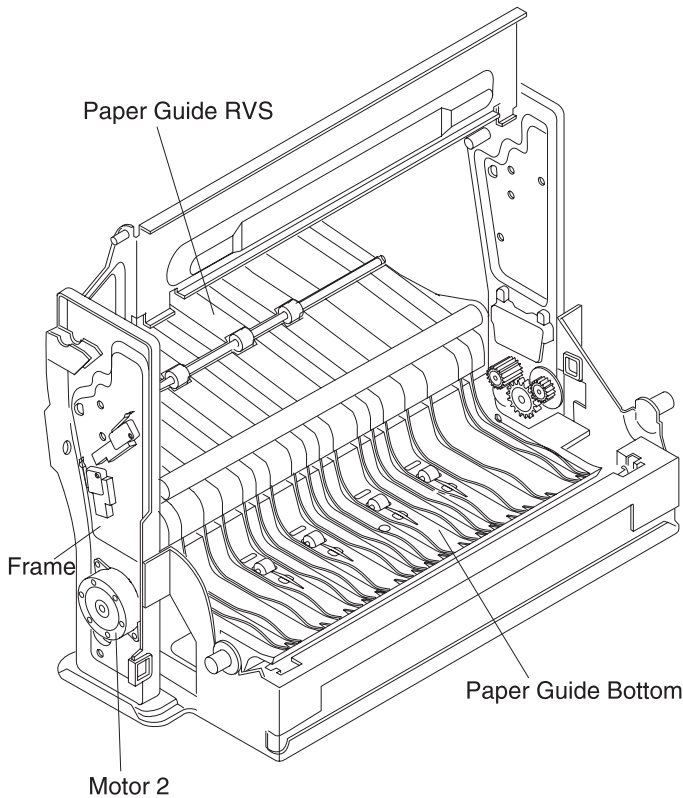

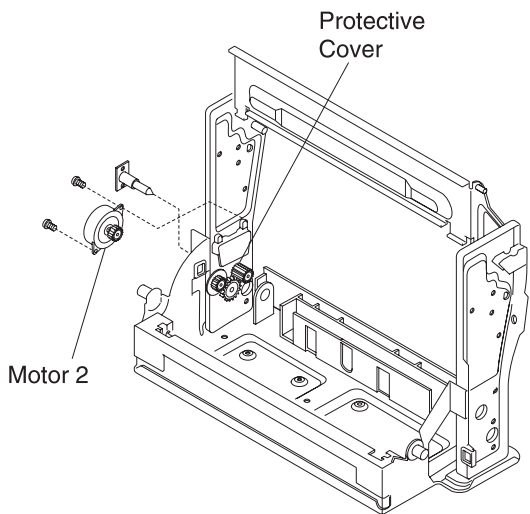



## Duplex Fan Motor Removal

1. Remove the side cover low (L). See **“Duplex Side Cover Low (L) Removal”** on page 4-106, for more information.
2. Remove the cover top (L). See **“Duplex Cover Top (L) Removal”** on page 4-108, for more information.
3. Disconnect the fan harness connector.
4. Remove the harness from the clamp.
5. Remove the set screws M4X30 (2) from the fan.
6. Remove the fan motor from the frame.

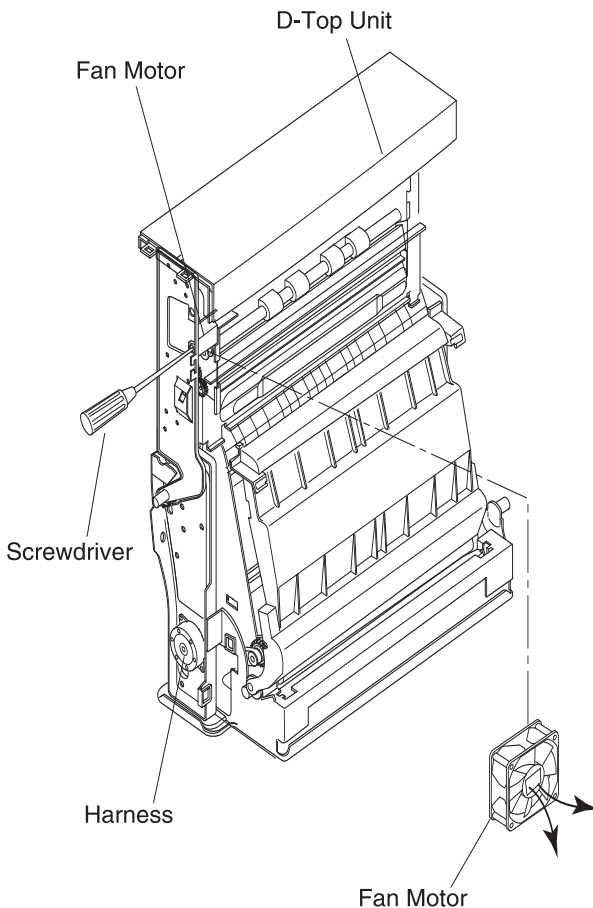

## Duplex Solenoid (U) Assembly Removal

1. Remove the side cover low (R). See **“Duplex Side Cover Low (R) Removal” on page 4-105**, for more information.
2. Remove the cover top (R). See **“Duplex Cover Top (R) Removal” on page 4-107**, for more information.
3. Disconnect the solenoid harness connector.
4. Remove the harness from the clamp.
5. Remove the set screws ST3X6 (2) from the solenoid (U) assembly.

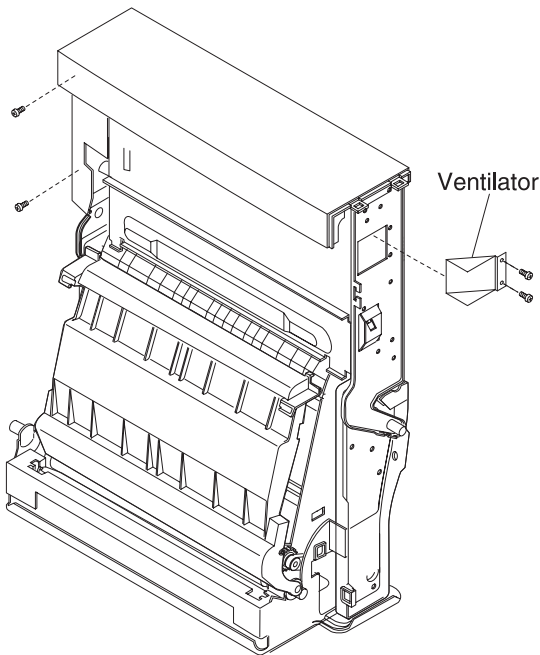

## Duplex Solenoid (L) Assembly Removal

1. Remove the paper guide bottom. See **“Duplex Paper Guide Bottom Removal”** on page 4-119, for more information.
2. Remove the harness cover.
3. Remove the solenoid (L) harness connector CN3 from the relay P.W.B.
4. Remove the harness from the clamp.
5. Remove the set screw ST3X5 (1) from the solenoid.
6. Remove the solenoid (L) assembly.

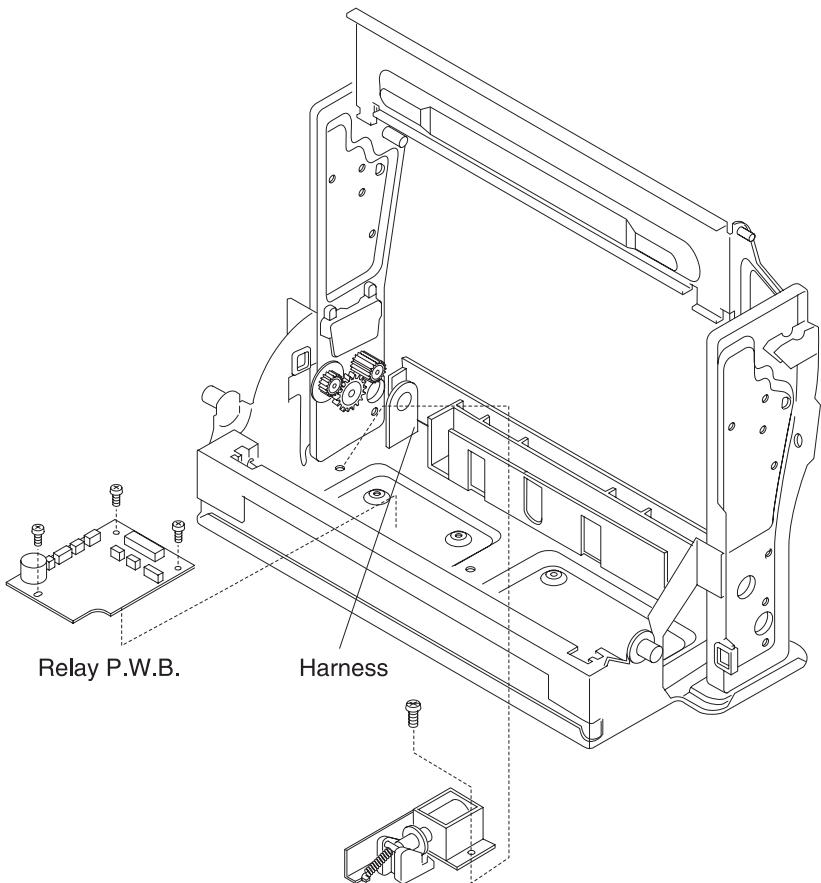

**WARNING:** Put the actuator in the lever hole of the switching shutter L while assembling the solenoid (L).

## Duplex Interlock Switch (D-SW1, D-SW2) Removal

1. Remove the side cover low (R). See “**Duplex Side Cover Low (R) Removal**” on page 4-105, for more information.
2. Remove the set screw ST3X14 (1) from the interlock switch.
3. Remove the harness connector to the interlock switch.
  - D-SW1: Interlock switch senses the top unit is open.
  - D-SW2: Interlock switch senses the side cover low (B) is open.

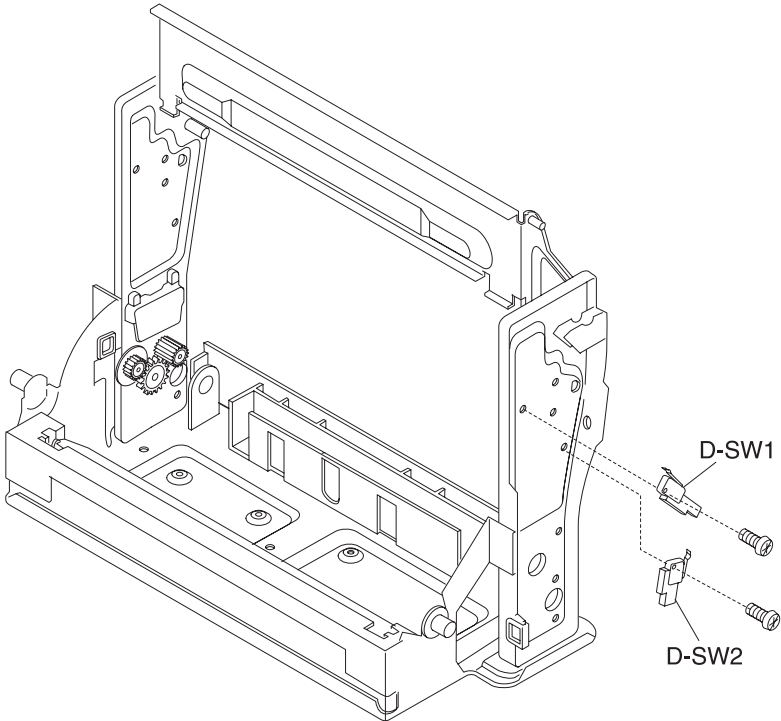

**WARNING:** After replacement of the interlock switch (R), confirm the switch operates normally by opening and closing the cover low (R).

## Duplex Interlock Switch (D-SW3, D-SW4) Removal

1. Remove the side cover low (L). See **“Duplex Side Cover Low (L) Removal”** on page 4-106, for more information.
2. Remove the set screw ST3X12 (1) from the interlock switch (R).
3. Remove the harness connector to the interlock switch (R).
  - D-SW3: Interlock switch senses the top unit is open.
  - D-SW4: Interlock switch senses the cover low (B) is open.

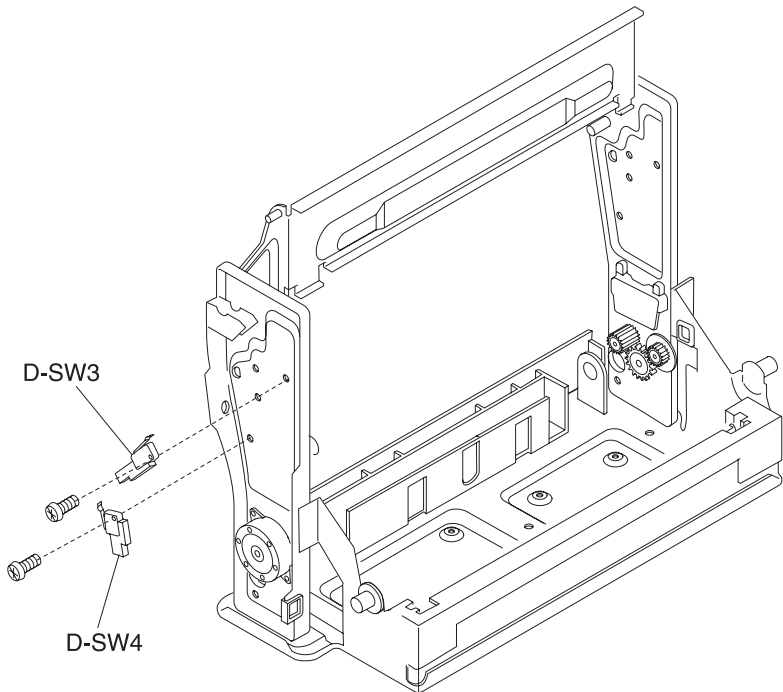

**WARNING:** After replacement of the interlock switch (R), confirm the switch operates normally by opening and closing the cover low (R).

## Duplex D Paper Sensor (PT5) Removal

1. Open the cover low (B).
2. Open the paper guide RVS IN.
3. Remove the set screw TS3X8 (1) from the cover low.
4. Remove the sensor cover.
5. Remove the PT5 from the paper guide RVS unit.

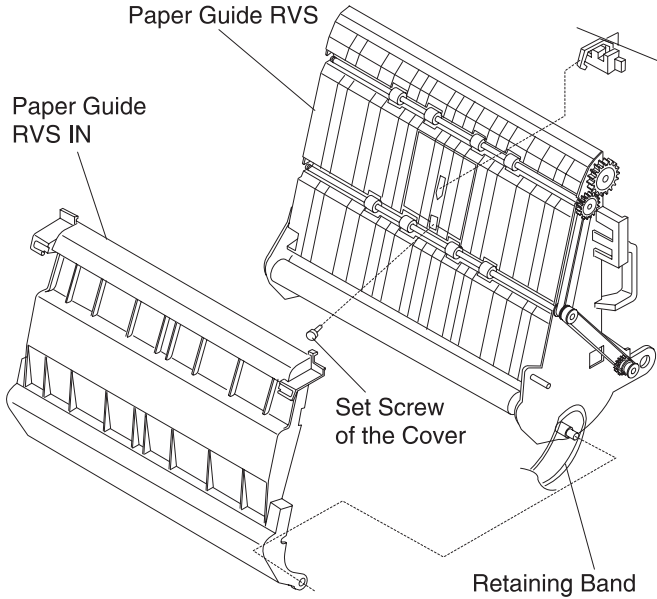

**Note:** Prior to replacement, make sure the connection is made.

## Duplex Paper Sensor Low (PT4) Removal

1. Remove the paper guide bottom. See **“Duplex Paper Guide Bottom Removal”** on page 4-119, for more information.
2. Remove the paper guide bottom assembly from the PT4 sensor.

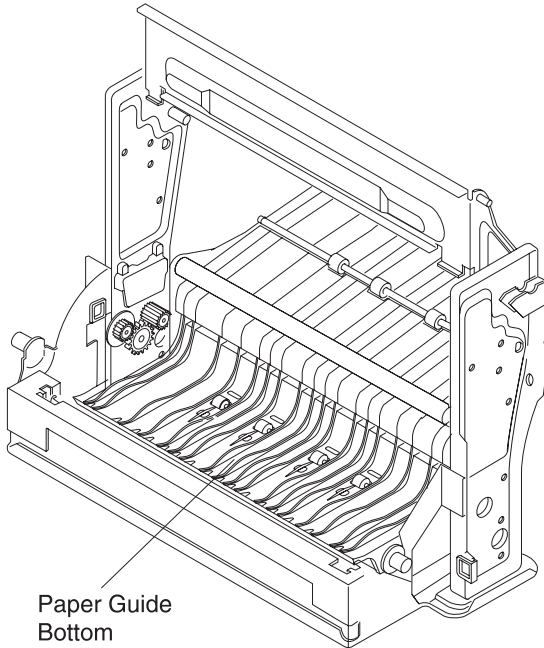

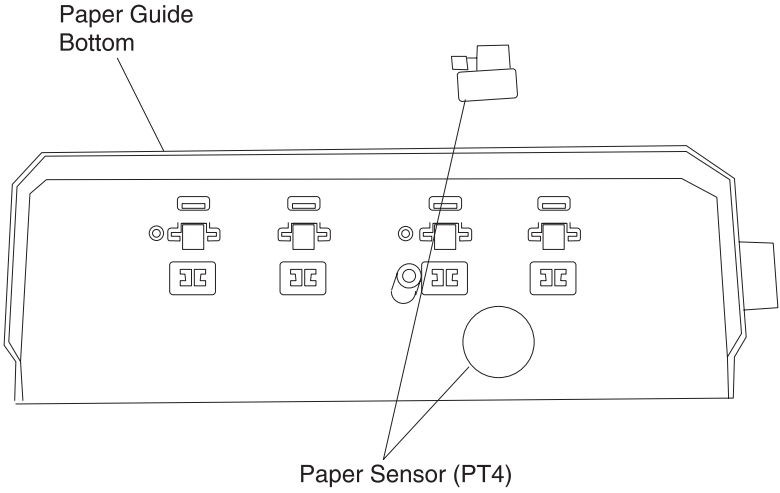

Back Side View

**Note:** Install the new PT4 sensor to the paper sensor bottom.



# 5. Locations

## Printer

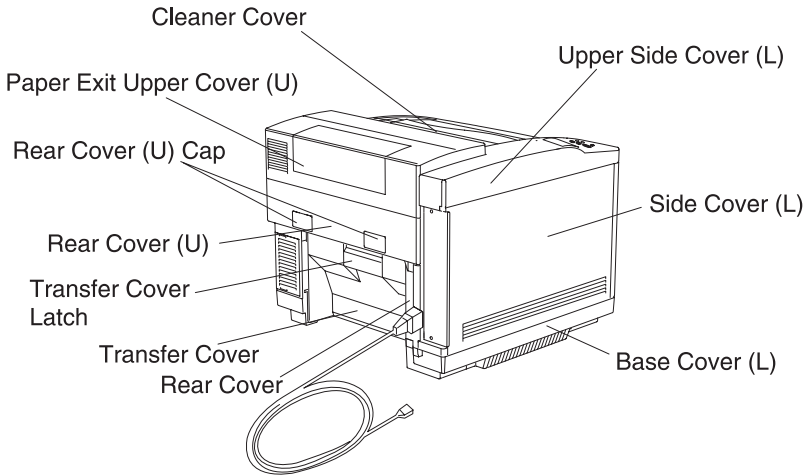
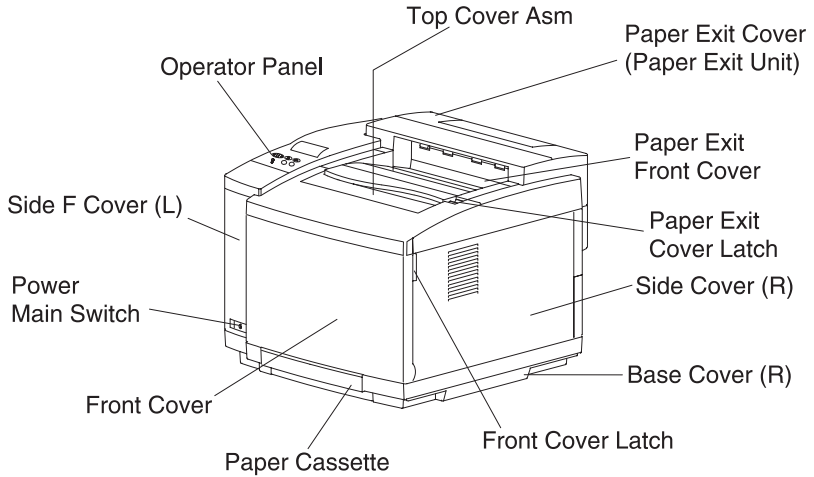

Part Name	Description
Top Cover	The upper enclosure and also the exit paper tray.
Operator Panel	Displays a status of printer operation.
Front Cover	Printer front enclosure, to be opened when replacing a toner cartridge or waste toner pack.
Paper Exit Cover	Exit tray for printed paper onto the top cover. Open the paper exit cover to replace the OPC belt cartridge.
Main Switch	Operates power-On and Off for the printer.
Remote Switch	Operation switch for the printer control voltage.
AC Input Inlet	Connects a power supply cable.
Back Cover (L)	Printer rear enclosure, to be opened when clearing an internal jam or doing maintenance work.
Interface Connector Box	Space for controller P.W.B. installation.
Paper Exit Upper Cover	This cover is removed when the duplex unit is installed.
Paper Stopper A	Stopper for exited papers.
Paper Stopper B	Stopper for exited papers.

5024-001

## Options

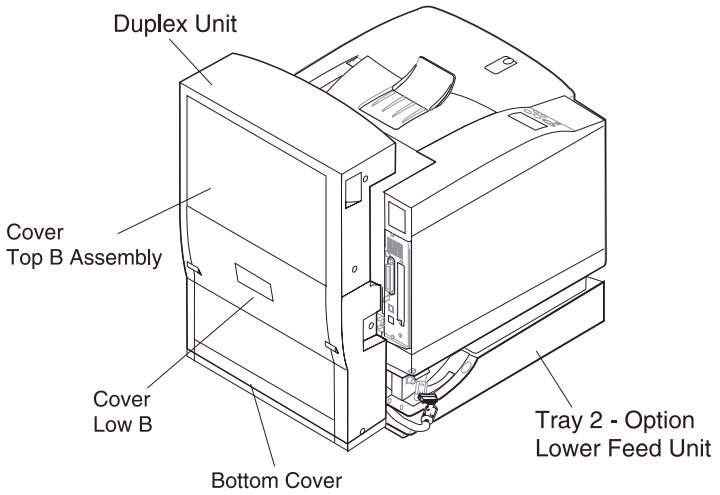
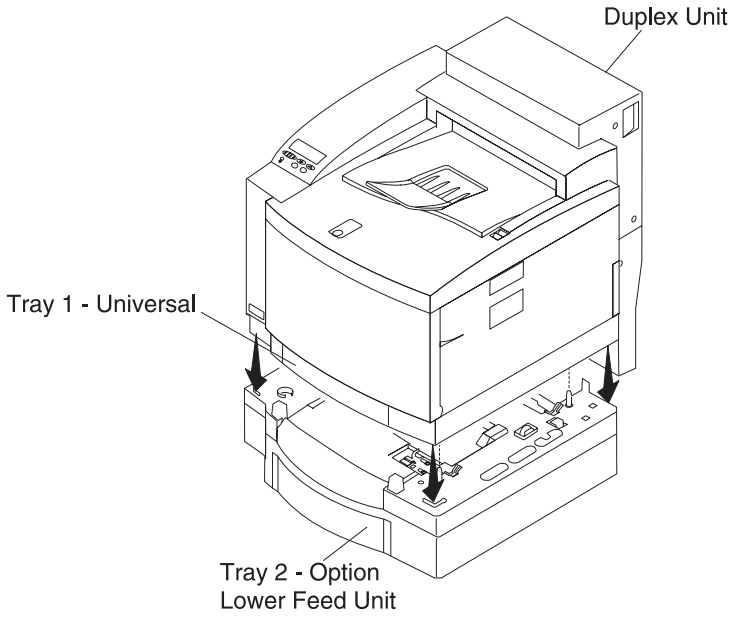

# Electronic Components

## Sensor Locations

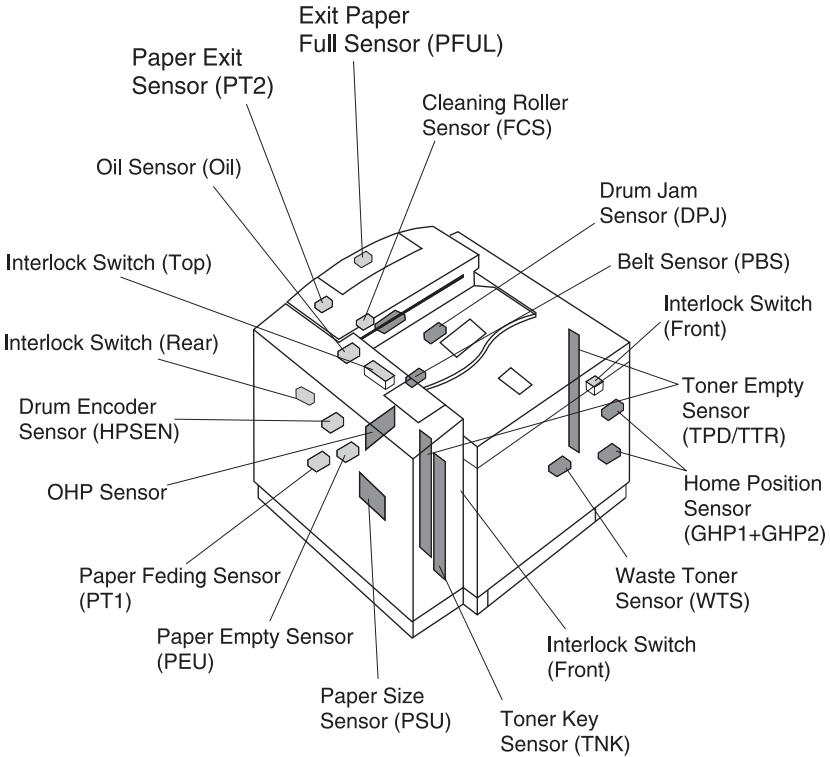

Name	Code	Function
Paper Size Sensor	PSU	Photo sensor to detect the paper size.
Paper feed Sensor	PT1	Photo sensor to detect whether paper is fed from the paper drawer.
Paper Exit Sensor	PT2	Photo sensor to detect whether paper is exited from the paper exit unit.
Paper Sensor	PEU	Photo sensor to detect whether paper is loaded in the paper drawer.

**5024-001**

<b>Name</b>	<b>Code</b>	<b>Function</b>
Oil Sensor	OIL	Photo sensor to detect whether the fuser unit oil is empty or not.
OHP Sensor	OHP	Photo sensor to detect whether paper is loaded in the paper drawer.
Drum Paper Jam Sensor	DPJ	Photo sensor to detect whether paper is winding around the transfer drum.
Drum Encoder Sensor	(HPSEN)	Photo sensor to detect irregular rotation of the transfer drum.
Photo Belt Sensor	PBS	Photo sensor to detect the connecting position of the OPC belt.
Toner empty sensor	TPD/TTR	Photo sensor to detect whether toner is empty for each toner cartridge.
Waste Toner Sensor	WTS (LED/TR)	Photo sensor to detect whether the waste toner bottle is full.
Home Position Sensor	GHP1, GHP2	Photo sensor to detect the early position of the toner cartridges.
Cleaning Roller Sensor	FCS	Photo sensor to detect whether the cleaning roller is available in the fuser unit.
Temperature Sensor for Fuser Unit	TH	Thermistor to detect the fuser temperature.
Exit Paper Full Sensor	PFUL	Detects that the paper exit tray is full.
Toner Key Sensor	TNK	Detects the availability of a key to be provided to the toner cartridge.

## Printer Circuit Board Locations

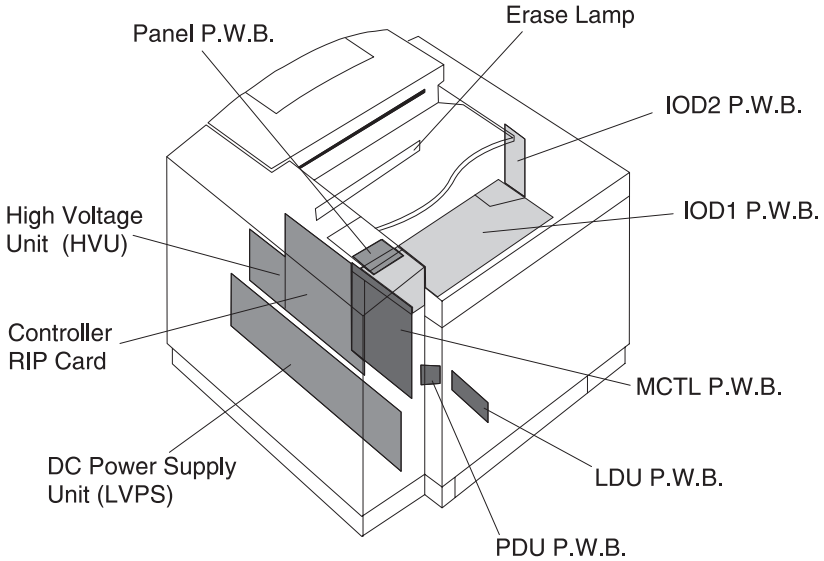

Name	Function
Main Engine (MCTL P.W.B.) Board	Controls the processes of the printer: Fuser Temperature control Laser output control Operator panel indication Toner empty sensing control Error processing control Interface control
Panel P.W.B.	Displays the printer operation status and supports the manual input switch.
LDU P.W.B.	Controls the drive and output of the laser diode included in the optical unit.
PDU P.W.B.	Senses the emission of laser diodes and the beam position in the optical unit.
Erase Lamp	Discharges the OPC belt by radiating the C belt included in the optical unit.

**5024-001**

<b>Name</b>	<b>Function</b>
IOD1 P.W.B.	Relays the signals between the controlled parts and main engine (MCTL P.W.B.) board, and drives the controlled parts.
IDO2 P.W.B.	Relays the signals between the controlled parts, the main engine (MCTL P.W.B.) board, and drives the controlled parts.
DC power supply unit (LVPS)	Provides power to control the printer.
High voltage power supply unit (HVU)	Provides power necessary for the printing process.
Controller RIP Card	Provides operator function.

## Fan/Motor Locations

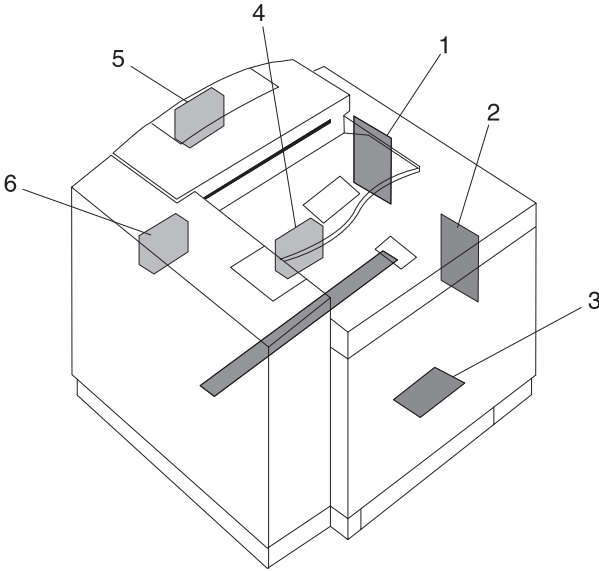

Name	Code	Function
Main Motor	M M	Drives the OPC belt and the paper transport system.
Developer Motor	D M	Drives the toner cartridge and the developing system.
Scanner Motor	S C M	Scans the laser beam in the optical unit
Controller Fan	CTLFAN	Exhausts the heat from the power supply unit and the interface controller.
Heater Fan	HTFAN	Exhausts the heat from the fusing unit.
Ozone Fan	OZFAN	Exhausts the ozone from the printer charger unit.



## Solenoid/Clutch Locations

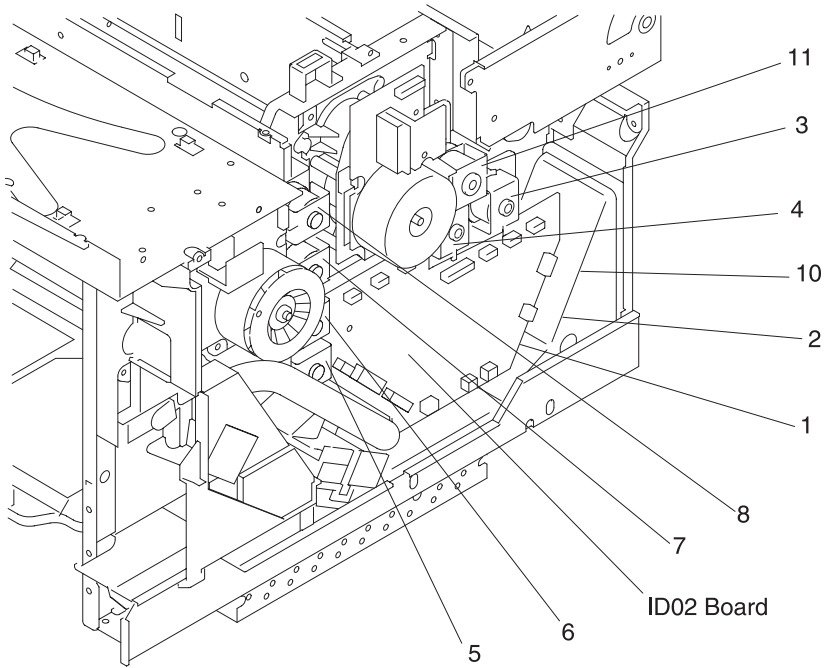

Name	Code	Function
Paper Feed Clutch	PCLU	<p>Feeds paper by coupling the feed roller to the main gear unit at the time of a paper feed.</p> <p>The paper feed clutch is located behind the ID02 board.</p>
Registration Clutch	RECL	<p>Transports paper by coupling the registration roller to the main gear unit as synchronized with the rotation of the transfer drum.</p> <p>The registration clutch is located behind the ID02 board.</p>
Fuser Clutch	FUCL	<p>Drives the fusing roller by coupling the fuser unit to the main gear unit.</p>

Name	Code	Function
Cleaner Clutch	FBCL	Drives the brush of the drum cleaner by coupling the cleaner clutch to the main gear unit at the time of the drum cleaning.
~ 8 Developer Clutch	DCL (Y,M,C,K)	Drives the cartridge by coupling the selected toner cartridge to the developer gear unit at the time of developing.
Developer Cam Clutch Unit	PSL (MC) PSL (KY)	Relocates the selected color toner cartridge to the development position at the time of developing.  The developer cam clutch is located in the front cover unit.
Transfer Cam Clutch	TRCM	Ensures the transfer roller contacts the transfer roller surface at the time of the second transfer.
Cleaner Cam Clutch	FBCM	Ensures the drum cleaner contacts the transfer roller surface at the time of the drum cleaning.

## Symbol and Part Name Table

Symbol	Part Name
BR	Back-up roller
CTFAN	Control fan motor (cooling fan PS)
DM	Developer motor
DPJ	Drum jam sensor
DSW1	Interlock switch (front)
DSW2	Interlock switch (top)
DSW3	Interlock switch (rear)
DUP	Duplex unit
DCLK DCLY DCLM DCLC	Developer clutch (K.Y.M.C.)
Erase lamp	Erase lamp
FBCL	Cleaning clutch
FBSOL	Cleaning cam clutch
FCS	Cleaning roller sensor
FUCL	Fuser clutch
FUSER unit	Fuser unit
HPSEN	Drum encoder sensor
HR	Heater roller
HTFAN	Heater fan motor (cooling fan EX)
HVU	High voltage unit
IOD1	IOD1 P.W.B.
IOD2	IOD2 P.W.B.
LCD	LCD P.W.B.

**5024-001**

<b>Symbol</b>	<b>Part Name</b>
LDU	Laser drive unit P.W.B.
LFU	Lower paper feeding unit
LVPS	Power supply unit
MCTL	Main Engine (MCTL P.W.B.) board
MM	Main motor
OHP	OHP sensor
OIL	Oil sensor
Optical unit	Optical unit
OZFAN	Ozone fan motor (cooling fan OZ)
PANEL	Operator panel P.W.B.
PBS	Belt sensor
PCLU	Upper paper feeding clutch
PDU	PDU P.W.B.
PEU	Upper paper empty sensor
PFUL	Exit paper full sensor
PSL (MC) PSL (KY)	Developer cam clutch
PSU	Upper paper size sensor
PT1	Paper feed sensor
PT2	Paper exit sensor
RECL	Registration clutch
SCM	Scanner motor
TBLE TBFL	Waste toner sensor (WT holder assembly)
TFU1 TFU2	Thermal fuse

Symbol	Part Name
TH	Themistor
TNK	Toner key sensor
TPD TTR	Toner empty sensor
TRCM	Transfer cam clutch

## Wiring Diagram / Cable Harness Reference

### Notes:

- Cables are marked, in large circles, with the # sign.
- Connectors are marked, in small circles, with number reference.
- See foldout, in the back of this manual, for an exploded view of this diagram.

**Note:** See foldout, in the back of this manual, for an exploded view of this diagram.

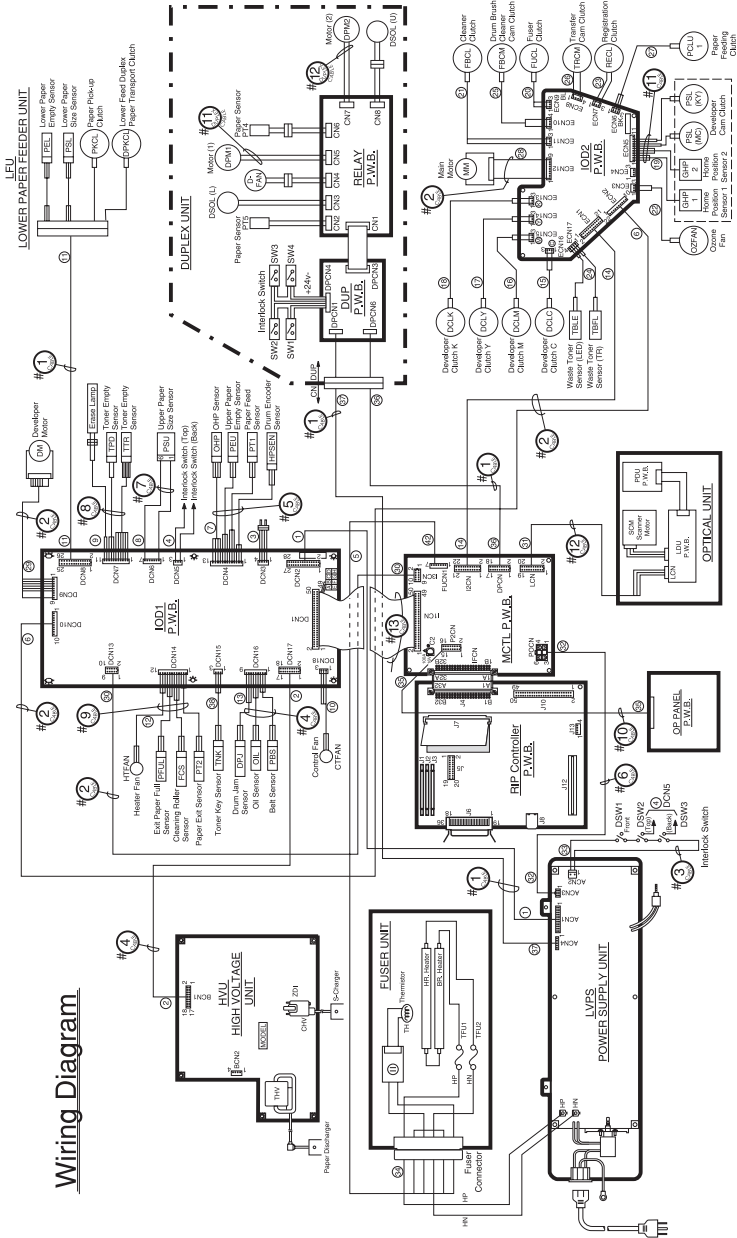

Wiring Diagram

# Controller RIP Card

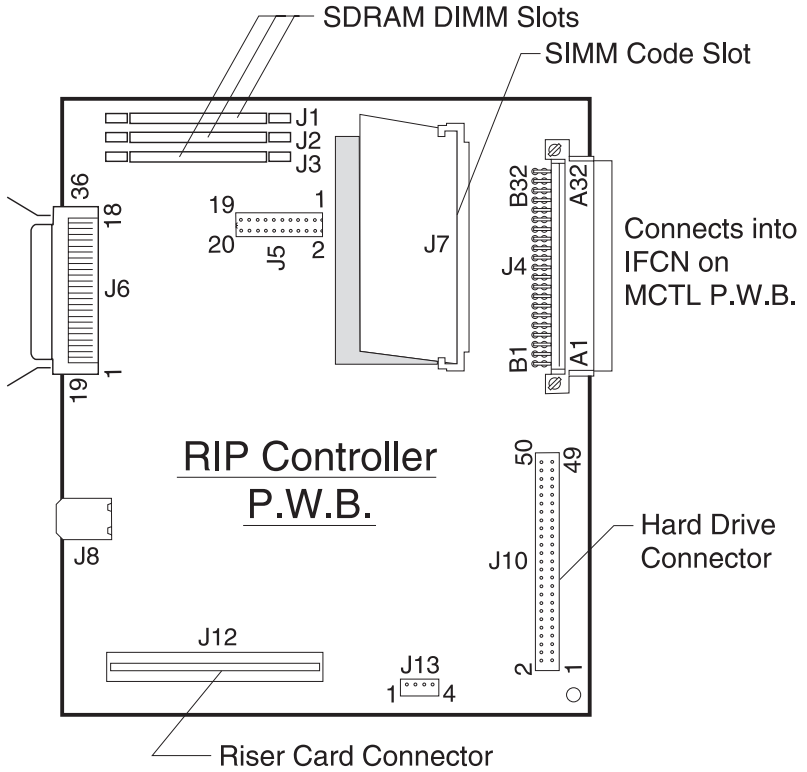





# IOD1 P.W.B. Board

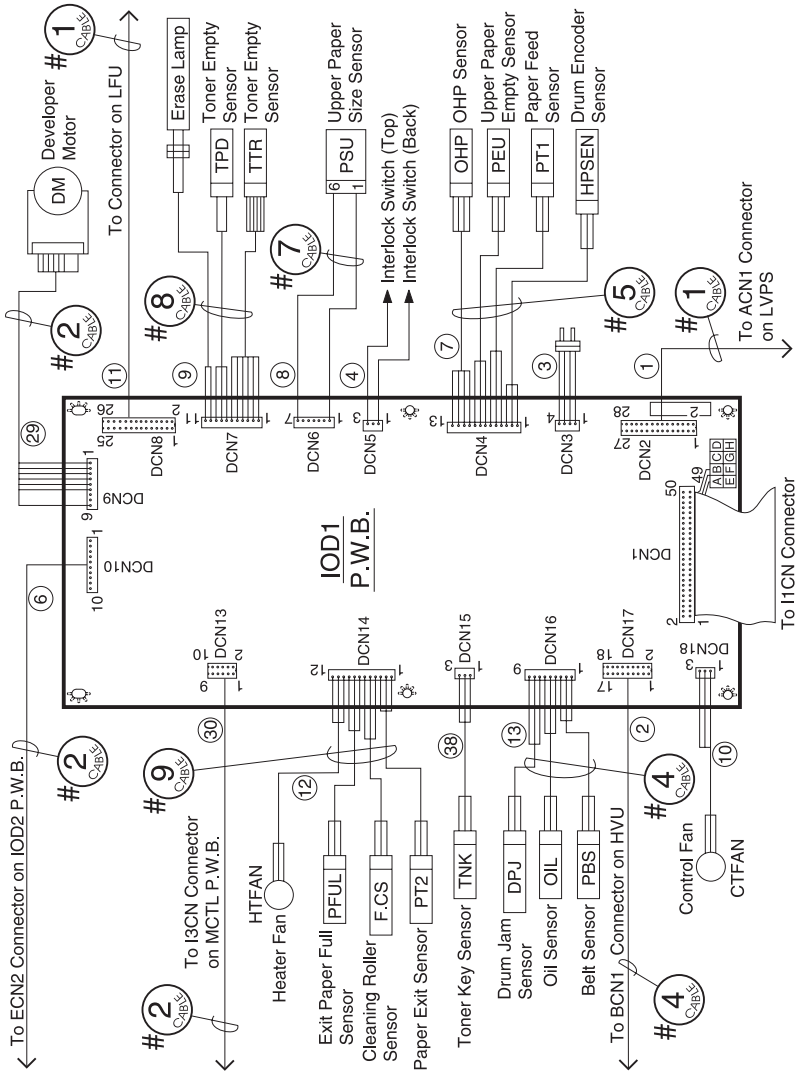

IOD2 P.W.B. Board

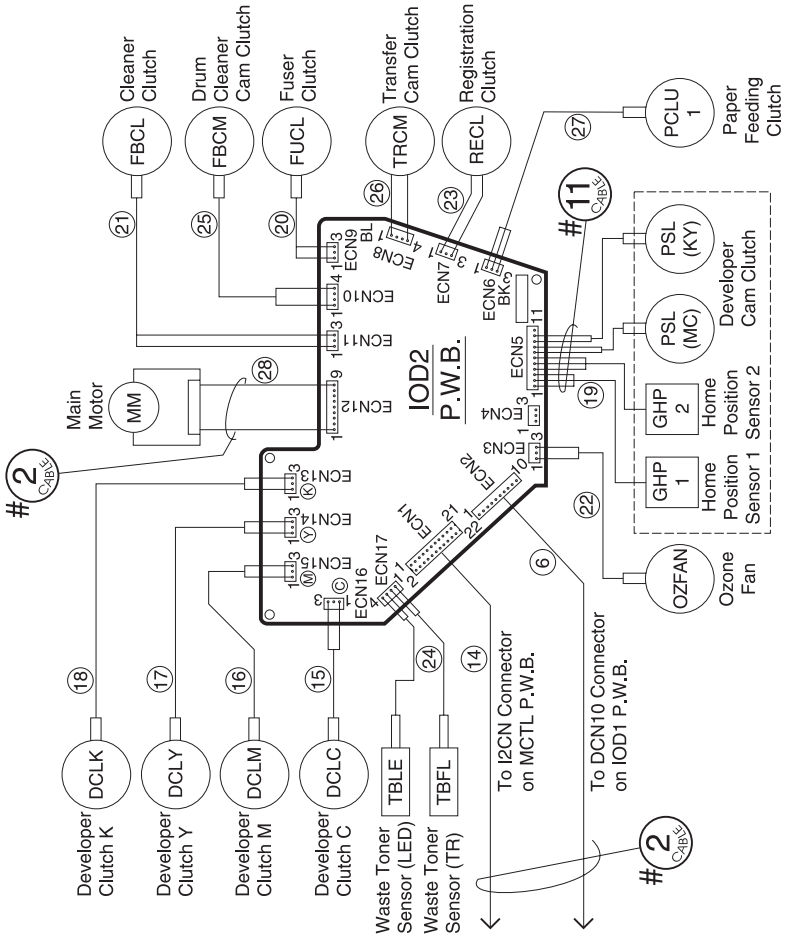

# Low Voltage Power Supply (LVPS) Board

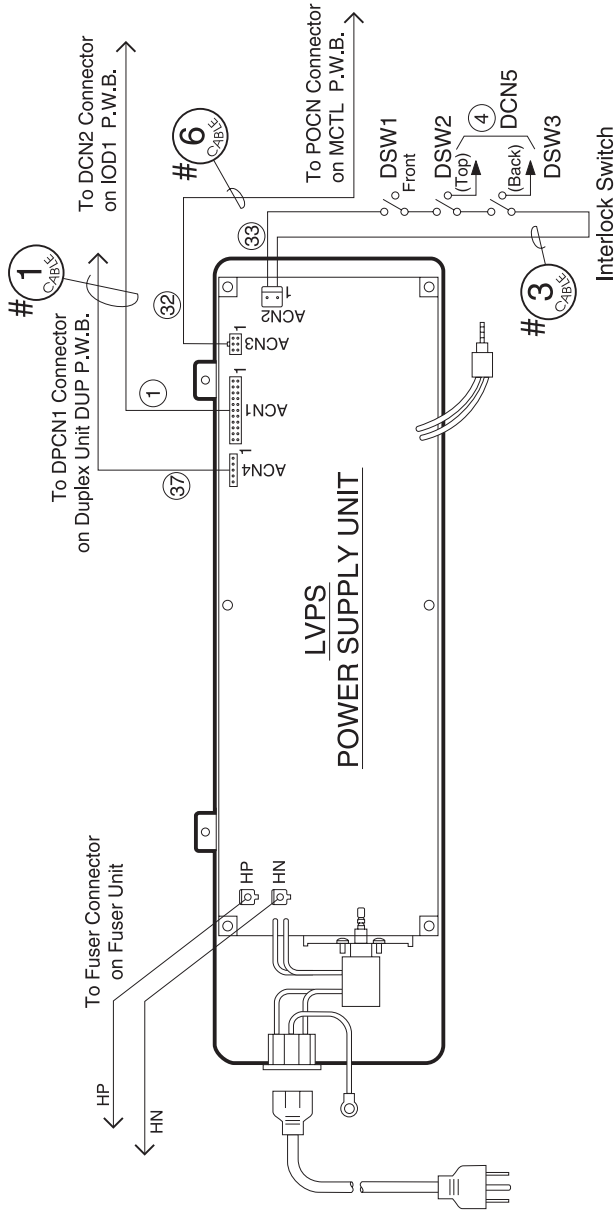

# High Voltage Unit (HVU) Board

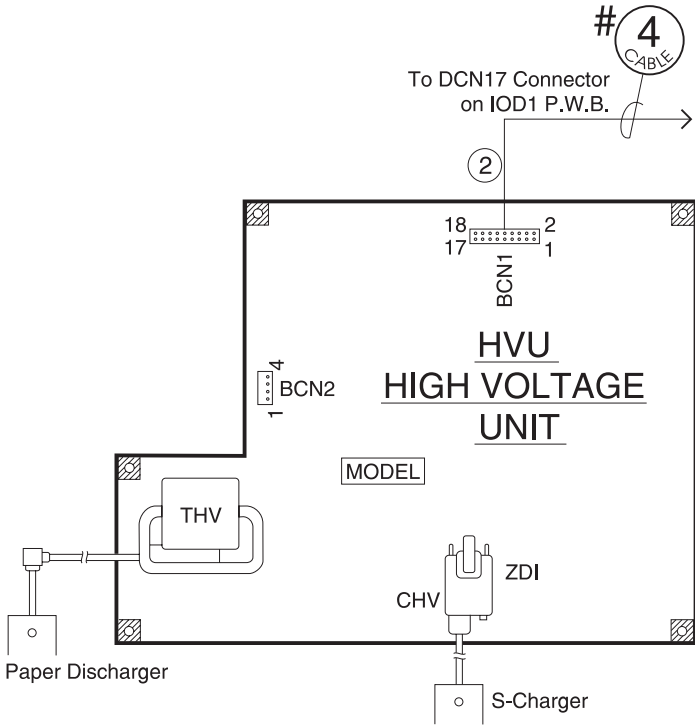

# Fuser Unit (LVPS) Board

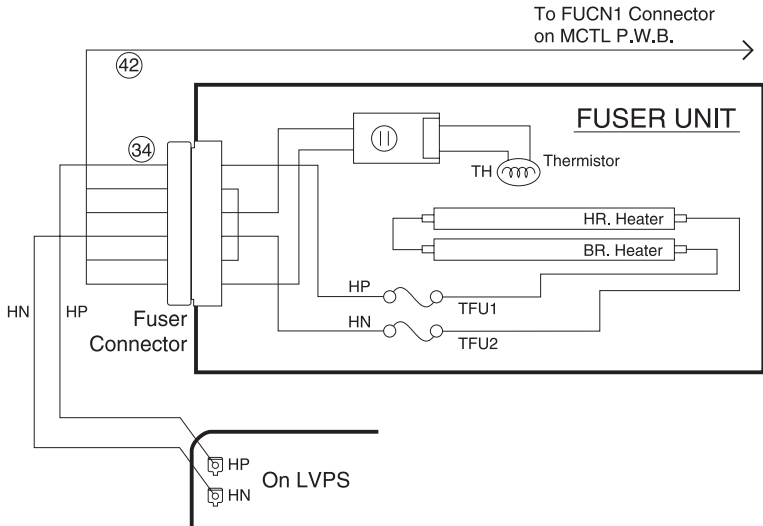

---

# Connector Locations for Options

## Lower Feed Unit Option

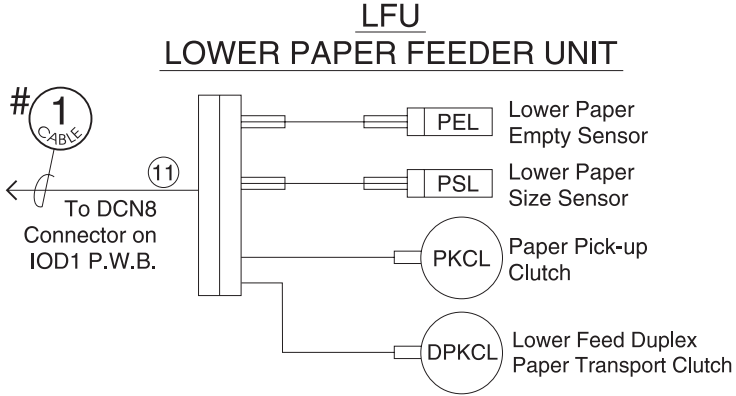

Duplex Unit

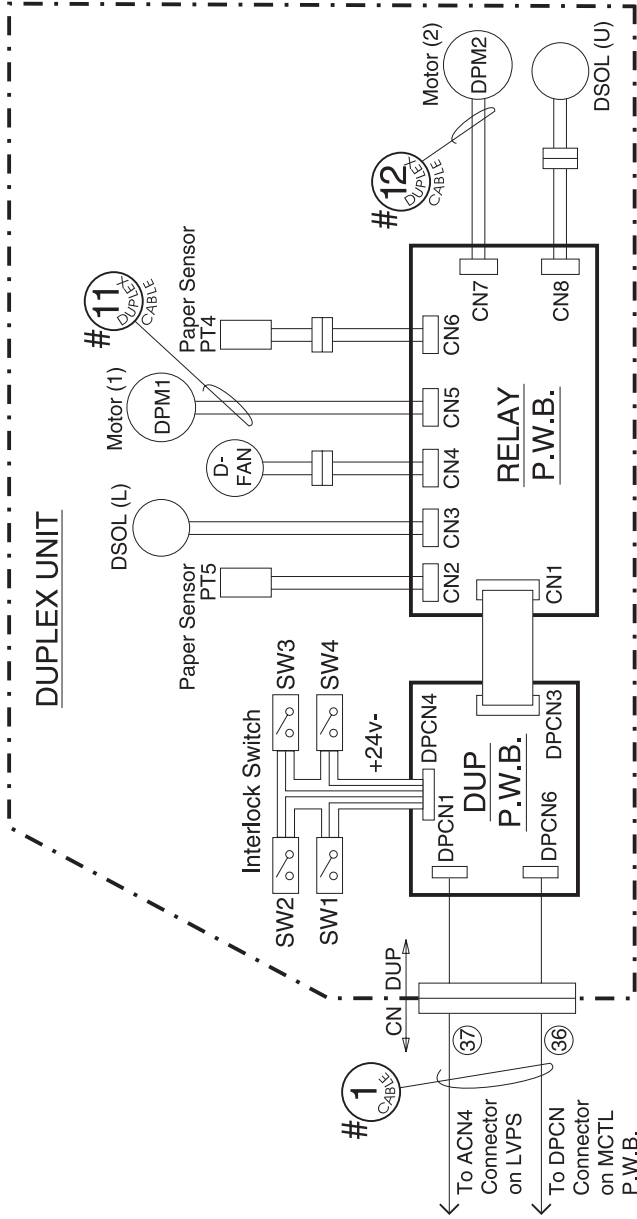

---

## Connector Pin Assignments

### Location 1

#### IOD1 P.W.B. DCN2—Power Supply Unit ACN1

**Note:** See Wiring Diagram (small circle) for location.

Pin No.	Signal Name	Pin No.	Signal Name
1	+5V-1	2	DCOFF2-P
3	+5V-1	4	SGND
5	+5V-D	6	SGND
7	+5V-D	8	SGND
9	ACSYNC-N	10	SGND
11	+24V	12	DCOFF1-P
13	+5V-1R	14	ACOFF-P
15	HON-N	16	TESTI2
17	+24V-1	18	TESTO2
19	+24V-1	20	TESTI1
21	+24V-1	22	TESTO1
23	+24V-1	24	PGND
25	PGND	26	PGND
27	PGND	28	PGND
29	DCOFF3-P	30	NC



## 5024-001

### Location 2

#### IOD1 P.W.B. DCN17—High Voltage Unit BCN1

**Note:** See Wiring Diagram (small circle) for location.

Pin No.	Signal Name	Pin No.	Signal Name
1	+24V-1	2	PGND
3	AVCERR	4	PGND
5	ACVON-N	6	PWMON-N
7	CHVON-N	8	CHVERR
9	CBVPWM-N	10	THVRON-N
11	DBV(MC)PWM-N	12	THVPWM-N
13	DBV(KY)PWM-N	14	THV-1
15	FCBVPMN-N	16	(Reserved)
17	AC_DCON-N	18	(Reserved)

### Location 3

#### Factory Use Only DCN3

### Location 4

#### IOD1 P.W.B. DCN5—Interlock Switch

**Note:** See Wiring Diagram (small circle) for location.

Pin No.	Signal Name	Pin No.	Signal Name
1	REARDOPEN-P	2	NC
3	TOPDOPEN-P		

## Location 5

### Main Engine (MCTL P.W.B.) Board (1CN)—IOD1 P.W.B. DCN1

**Note:** See Wiring Diagram (small circle) for location.

Pin No.	Signal Name	Pin No.	Signal Name
1	I/OAD2	2	DMON-N
3	I/OAD1	4	DCOFF1-P
5	I/OAD0	6	DMCLK
7	I/ODATA3	8	ACVON-N
9	I/OADATA2	10	CHVON-N
11	I/OADATA1	12	PWMON-N
13	I/OADATA0	14	CBVPWM-N
15	LEDON-N	16	DBV(MC)PWM-N
17	DMRDY-N	18	DBV(KY)PWM-N
19	I/ODATA4(REV11)	20	FCBVPWM-N
21	(Reserved)	22	THVRON-N
23	AC_DCON-N	24	THVPWM-N
25	PKCLL1ON-P	26	THV-I
27	ELON-P	28	(Reserved)
29	PBSEN-N	30	(Reserved)
31	HPSEN-N	32	OILLES-P
33	CTFANON-P	34	FUTEMP
35	HTFANON-P	36	HON-N
37	+5V-1R	38	ACOFF-P
39	SGND	40	ACSYNC-N
41	SGND	42	+24V
43	SGND	44	PGND

## 5024-001

Pin No.	Signal Name	Pin No.	Signal Name
45	+5V-1	46	PGND
47	+5V-1	48	+24V-1
49	+5V-1D	50	+24V-1

## Location 6

### IOD1 P.W.B. DCN10—IOD2 P.W.B. ECN2

**Note:** See Wiring Diagram (small circle) for location.

Pin No.	Signal Name	Pin No.	Signal Name
1	+24V-1	2	+24V-1
3	+24V-1	4	PGND
5	PGND	6	PGND
7	+5V-1	8	SGND
9	SGND	10	+5VS

## Location 7

### IOD1 P.W.B. DCN4—Upper Paper Empty Sensor (PSU)

- Paper Feed Sensor (PT1)
- Drum Encoder Sensor (HPSEN)
- OPH Sensor (OPH)

**Note:** See Wiring Diagram (small circle) for location.

Pin No.	Signal Name	Pin No.	Signal Name
1	+5V-S	2	HPSEN-N
3	SGND	4	+5V-S
5	PT1-N	6	SGND
7	+5V-S	8	PEU-P
9	SGND	10	+5V-S
11	OHPSENU	12	SGND
13	SGND		

## Location 8

### IOD1 P.W.B. DCN6—Upper Paper Size Sensor

**Note:** See Wiring Diagram (small circle) for location.

Pin No.	Signal Name	Pin No.	Signal Name
1	+5V-D	2	PSU1
3	PSU2	4	PSU3
5	PSU4	6	PSU5
7	SGND		

**Location 9****IOD1 P.W.B. DCN7—Toner Empty Sensor (Y,M,C,K) Erase Lamp**

**Note:** See Wiring Diagram (small circle) for location.

Pin No.	Signal Name	Pin No.	Signal Name
1	TLES(K)-P	2	TLES(Y)-P
3	TLES(M)-P	4	TLES(C)-P
5	TLES-G	6	SGND
7	LEDON-P	8	TLESCHK
9	SGND	10	+24V-1
11	ELON-N		

**Location 10****IOD1 P.W.B. DCN18—Controller Fan**

**Note:** See Wiring Diagram (small circle) for location.

Pin No.	Signal Name	Pin No.	Signal Name
1	CTFANON-P	2	PGND
3	CTFANERR		

## Location 11

### IOD1 P.W.B. DCN8—Lower Paper Feeder Unit

**Note:** See Wiring Diagram (small circle) for location.

Pin No.	Signal Name	Pin No.	Signal Name
1	+24V-1	2	PKCLL1ON-N
3	FDCLL1ON-N	4	PSL1
5	PSL2	6	PSL3
7	PSCST1	8	PEL1-P
9	OCST1-N	10	NC
11	+5V-D	12	SGND
13	NC	14	+24V-1
15	NC	16	NC
17	NC	18	NC
19	NC	20	NC
21	NC	22	NC
23	(Reserved)	24	24+5V-D
25	SGND	26	SGND

## Location 12

### IOD1 P.W.B. EDCN14—Heater Fan (HTFAN)

- Paper Exit Sensor (PT2)
- Cleaning Roll Sensor (CSR)
- Paper Full Sensor (PFUL)

**Note:** See Wiring Diagram (small circle) for location.

Pin No.	Signal Name	Pin No.	Signal Name
1	+5V-S	2	PT2-N
3	SGND	4	+5V-S
5	CLROL-N	6	SGND
7	+5V-S	8	PEFULL-N
9	SGND	10	HTFANON-P
11	PGND	12	HTFANERR

## Location 13

### IOD1 P.W.B. EDCN16—Belt Sensor /Oil Sensor/Drum Jam Sensor

**Note:** See Wiring Diagram (small circle) for location.

Pin No.	Signal Name	Pin No.	Signal Name
1	PBSEN-N	2	+5V-1
3	SGND	4	OILLES-P
5	+5V1	6	SGND
7	7PDSEN-N	8	+5V-S
9	SGND	10	NC

## Location 14

### Main Engine (MCTL P.W.B.) Board 12CN—IOD2 ECN1

**Note:** See Wiring Diagram (small circle) for location.

Pin No.	Signal Name	Pin No.	Signal Name
1	DCL(C)ON-P	2	DCL(M)ON-P
3	DCL(Y)ON-P	4	DCL(K)ON-P
5	PSL(KY)ON-P	6	PSL(MC)ON-P
7	MMCLK	8	MMON-N
9	MMREV-N	10	MMENC
11	RECLON-P	12	AHUMB
13	ISCK	14	IDATA
15	ILOAD	16	FBCLON-P
17	FBSLON-P	18	TRSLON-P
19	OZFANON-P	20	FUCLON-P
21	PKCLU1ON-P	22	NC
23	(Reserved)	24	NC

## Location 15

### IOD2 P.W.B. ECN16—Developer Clutch (C)

**Note:** See Wiring Diagram (small circle) for location.

Pin No.	Signal Name	Pin No.	Signal Name
1	+24V-1	2	NC
3	DCL(C)ON-N		



5024-001

## Location 16

### IOD2 P.W.B. ECN15—Developer Clutch (M)

**Note:** See Wiring Diagram (small circle) for location.

Pin No.	Signal Name	Pin No.	Signal Name
1	+24V-1	2	NC
3	DCL(M)ON-N		

## Location 17

### IOD2 P.W.B. ECN14—Developer Clutch (Y)

**Note:** See Wiring Diagram (small circle) for location.

Pin No.	Signal Name	Pin No.	Signal Name
1	+24V-1	2	NC
3	CL(Y)ON-N		

## Location 18

### IOD2 P.W.B. ECN13—Developer Clutch (K)

**Note:** See Wiring Diagram (small circle) for location.

Pin No.	Signal Name	Pin No.	Signal Name
1	+24V-1	2	NC
3	DCL(K)ON-N		

## Location 19

### IOD2 P.W.B. ECN5—Home Position Sensor 1

- Home Position Sensor 2
- Developer Cam Clutch (YM)
- Developer Cam Clutch (YM)
- Developer Cam Clutch (CK)

**Note:** See Wiring Diagram (small circle) for location.

Pin No.	Signal Name	Pin No.	Signal Name
1	+5V-S	2	GHPSEN1-N(MC)
3	SGND	4	+5V-S
6	SGND	7	PSL(MC)ON-N
8	+24V-1	9	+24V-1
10	PSL(KY)ON-N	11	NC

## Location 20

### IOD2 P.W.B. ECN9—Fuser Clutch

See Wiring Diagram (small circle) for location.

Pin No.	Signal Name	Pin No.	Signal Name
1	+24V-1	2	NC
3	FUCLON-N		

5024-001

## Location 21

### IOD2 P.W.B. ECN11—Cleaner Clutch

**Note:** See Wiring Diagram (small circle) for location.

Pin No.	Signal Name	Pin No.	Signal Name
1	+24V-1	2	NC
3	FUCLON-N		

## Location 22

### IOD2 P.W.B. ECN3—Ozone Fan

**Note:** See Wiring Diagram (small circle) for location.

Pin No.	Signal Name	Pin No.	Signal Name
1	OZFANON-P	2	PGND
3	OZFANERR		

## Location 23

### IOD2 P.W.B. ECN7—Registration Clutch

**Note:** See Wiring Diagram (small circle) for location.

Pin No.	Signal Name	Pin No.	Signal Name
1	+24V-1	2	NC
3	RECLON-N		

5024-001

## Location 24

### IOD2 P.W.B. ECN17—Waste Toner Sensor

**Note:** See Wiring Diagram (small circle) for location.

Pin No.	Signal Name	Pin No.	Signal Name
1	TBFL1-N	2	SGND
3	WTLEDON	4	SGND

## Location 25

### IOD2 P.W.B. ECN10—Cleaner Cam Clutch

**Note:** See Wiring Diagram (small circle) for location.

Pin No.	Signal Name	Pin No.	Signal Name
1	+24V-1	2	NC
3	NC	4	FBSLON-N

## Location 26

### IOD2 P.W.B. ECN8—Transfer Cam Clutch

**Note:** See Wiring Diagram (small circle) for location.

Pin No.	Signal Name	Pin No.	Signal Name
1	+24V-1	2	NC
3	NC	4	TRSLON-N

5024-001

## Location 27

### IOD2 P.W.B. ECN6—Paper Feeding Clutch

**Note:** See Wiring Diagram (small circle) for location.

Pin No.	Signal Name	Pin No.	Signal Name
1	+24V-1	2	NC
3	PKCLU1ON-N		

## Location 28

### IOD2 P.W.B. ECN12—Main Motor

**Note:** See Wiring Diagram (small circle) for location.

Pin No.	Signal Name	Pin No.	Signal Name
1	MMRDY-N	2	MMON-N
3	MMCLK	4	PGND
5	+24V-1	6	SGND
7	+5V-1	8	MMENC
9	MMREV-N		

**Location 29****IOD1 P.W.B. DCN9—Developer Motor**

**Note:** See Wiring Diagram (small circle) for location.

Pin No.	Signal Name	Pin No.	Signal Name
1	DMRDY-N	2	DMON-N
3	DMCLK	4	PGND
5	PGND	6	+24V-1
7	+24V-1	8	SGND
9	+5V-1		

**Location 30****Main Engine (MCTL P.W.B.) Board I3CN—IOD1 P.W.B. DCN13**

**Note:** See Wiring Diagram (small circle) for location.

Pin No.	Signal Name	Pin No.	Signal Name
1	NC	2	(Reserved)
3	DCOFF3-N	4	(Reserved)
5	CTFANERR	6	OPD1VOFF-P
7	TH3	8	DCOFF2-N
9	(Reserved)	10	(Reserved)

**Location 31****Main Engine (MCTL P.W.B.) Board LCN—LDU P.W.B.)**

**Note:** See Wiring Diagram (small circle) for location.

Pin No.	Signal Name	Pin No.	Signal Name
1	+5V-1R	2	LDREF2
3	LDREF3	4	+5V-1
5	LDREF1	6	LDREF0
7	LREADY	8	LCONT2
9	LCONT1	10	VIDEO-N
11	LDREF4	12	BDT-P
13	BDT-N	14	SGND
15	SGND	16	SCMCLK
17	SCMRDY-N	18	SCMON-N
19	PGND	20	+24V-1

**Location 32****Power Supply Unit ACN3—(MCTL P.W.B.) POCN**

**Note:** See Wiring Diagram (small circle) for location.

<b>Pin No.</b>	<b>Signal Name</b>	<b>Interface</b>
1	SWRUS-P	Power supply (open)
2	+5V-2	+5V-2 Output
3	+5V-2D	+5V-2D Output
4	+5V-2D	+5V-2D Output signal ground
5	+24VDO-N	+24V Door open
6	SGND	Signal ground (+5V type ground)
7	SGND	Signal ground (+5V type ground)
8	SGND	Signal ground (+5V type ground)

**Location 33****Power Supply Unit ACN2—Interlock Switch**

**Note:** See Wiring Diagram (small circle) for location.

<b>Pin No.</b>	<b>Signal Name</b>	<b>Interface</b>
1	DSW-O	+24V Output through door switch
2	DSWI	+24V Output through door switch

**Location 34**

**Eliminated**



5024-001

## Location 35

Main Engine (MCTL P.W.B.) Board P2CN—PANEL P.W.B.

**Note:** See Wiring Diagram (small circle) for location.

Pin No.	Signal Name	Pin No.	Signal Name
1	I2C - DATA	2	+5V-1
3	I2-CLK	4	GND
5	FRIRQP-N		

## Location 36

Main Engine (MCTL P.W.B.) Board DPCN—Duplex Unit CNDUP

**Note:** See Wiring Diagram (small circle) for location.

Pin No.	Signal Name	Pin No.	Signal Name
1	D-COMMAND	2	SGND
3	DUMBUSY2-N	4	SGND
5	D-STATUS	6	SGND
7	(Reserved)	8	DUPCHK-N
9	DUMBUSY1-N	10	PT-1
11	DUPRES-N	12	SGND

**Location 37****Power Supply Unit ACN4—Duplex Unit CNDUP**

**Note:** See Wiring Diagram (small circle) for location.

Pin No.	Signal Name	Pin No.	Signal Name
1	+5V-1	2	+5V-D
3	SGND	4	+24V-2
5	+24V-2	6	PGND
7	PGND		

**Location 38****IOD1 P.W.B. DCN15—Toner Key Sensor**

**Note:** See Wiring Diagram (small circle) for location.

Pin No.	Signal Name	Pin No.	Signal Name
1	TONEROK-N	2	+5V-S
3	SGND		

**Location 39****Printer CNDUP—Duplex Unit**

**Note:** See Wiring Diagram (small circle) for location.

Pin No.	Signal Name	Pin No.	Signal Name
1	D-COMMAND	2	SGND
3	DUMBUSY2-N	4	SGND
5	D-STATUS	6	SGND
7	Reserved	8	DUPCHK-N
9	DUMBUSY1-N	10	PT-1
11	DUPRES-N	12	SGND
13	NC	14	NC
15	PGND	16	PGND
17	+24V-2	18	+24V-2
19	+5V-D	20	SGND
21	+5V-1	22	NC
23	NC	24	NC

**Location 40****Fuser Unit**

**Note:** See Wiring Diagram (small circle) for location.

Pin No.	Signal Name	Pin No.	Signal Name
A1	NC	A2	TH2
A3	NC	A4	TH1
B1	FUCHKGND	B2	FUTEMP
B3	NC	B4	NC
1	HN	2	HP
3	NC	4	NC

**Location 41**

**Note:** See Wiring Diagram (small circle) for location.

Pin No.	Signal Name	Pin No.	Signal Name
A1	TH1	A2	NC
A3	TH2	A4	NC
B1	NC	B2	NC
B3	FUTEMP	B4	FUCHKGND
1	HN	2	HP
3	NC	4	NC

5024-001

## Location 42

### Main Engine (MCTL P.W.B.) Board—FUCN1 Fuser Unit

**Note:** See Wiring Diagram (small circle) for location.

Pin No.	Signal Name	Pin No.	Signal Name
1	TH1	2	TH1
3	TH2	4	TH2
5	FUTEMP	6	FUCHKGND

# Printer Cables

## Cable 1 Connector Assignments

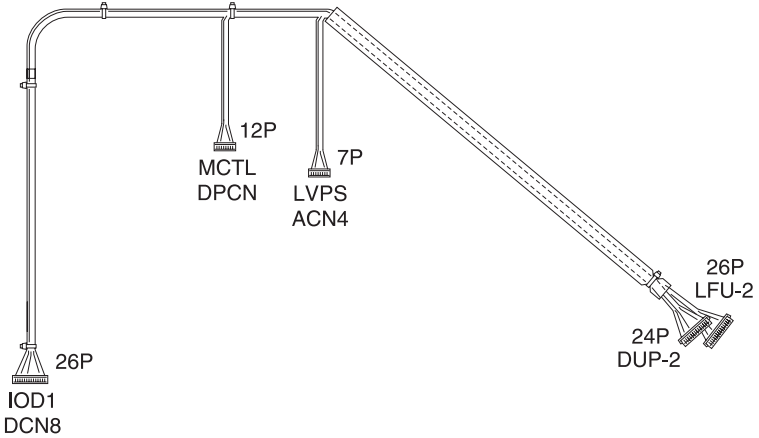

## Cable 2 Connector Assignments

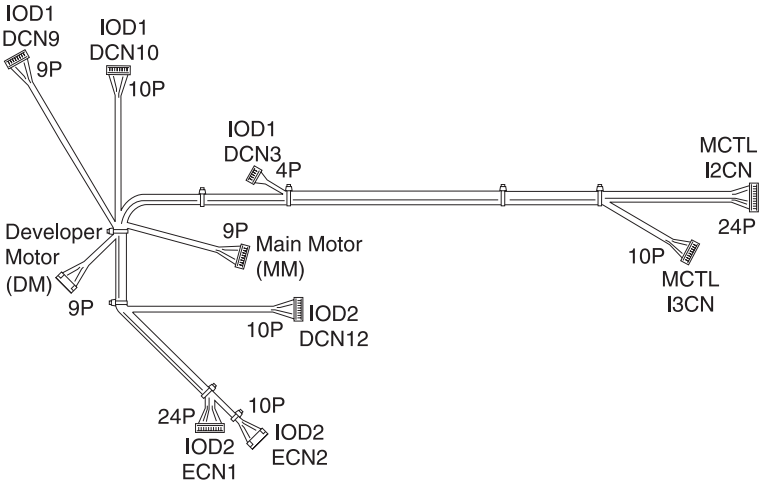

### Cable 3 Connector Assignments

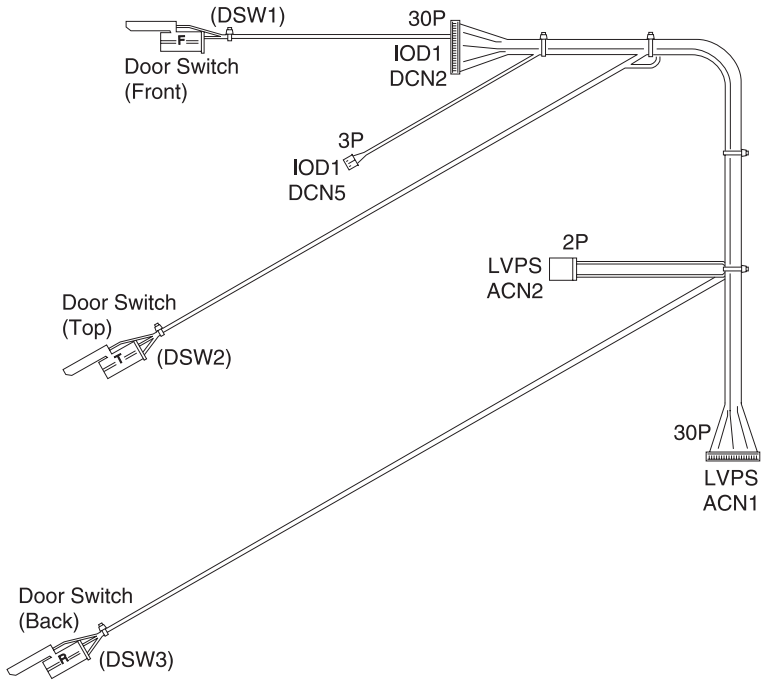

# Cable 4 Connector Assignments

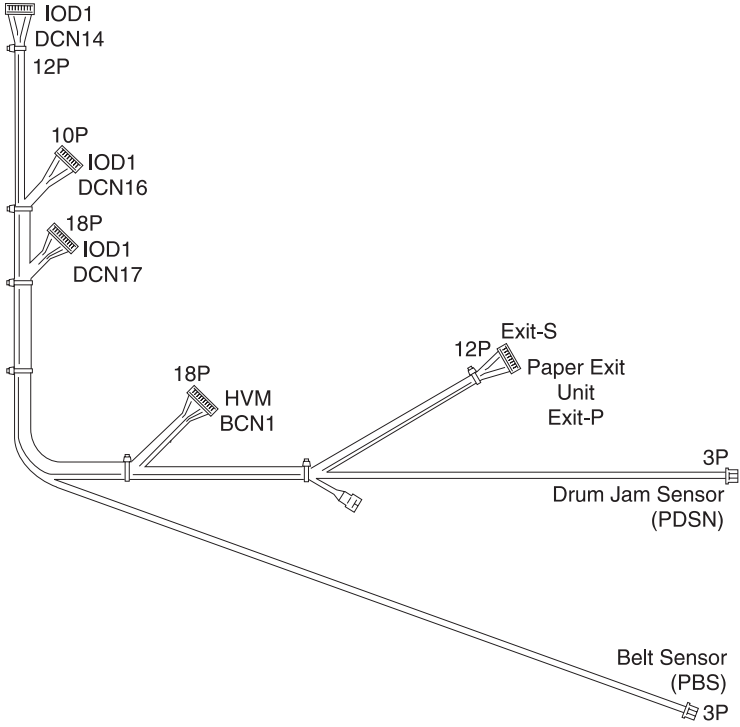



### Cable 5 Connector Assignments

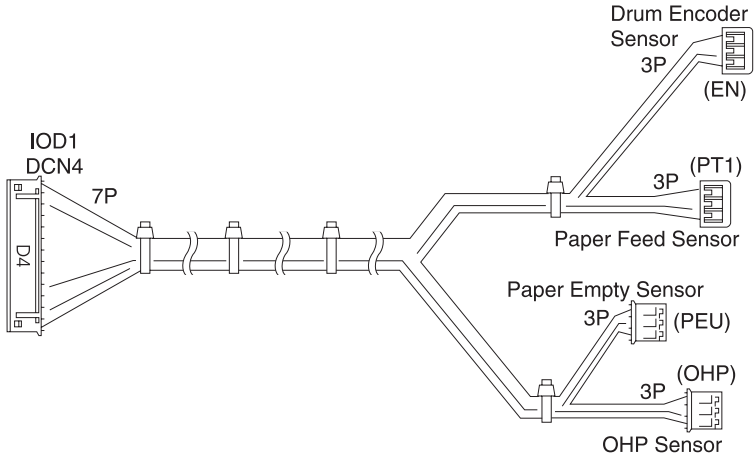

### Cable 6 Connector Assignments

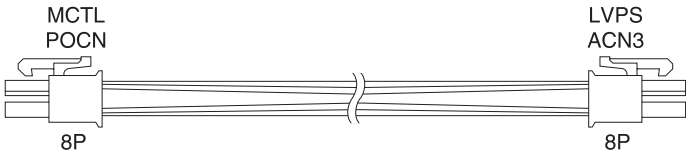

### Cable 7 Connector Assignments

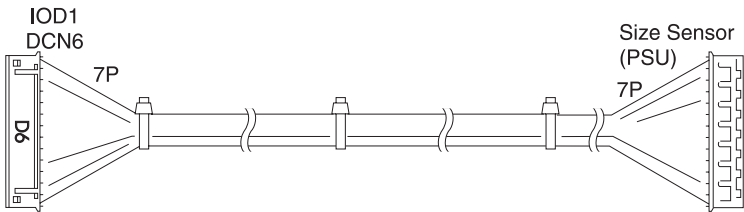

### Cable 8 Connector Assignments

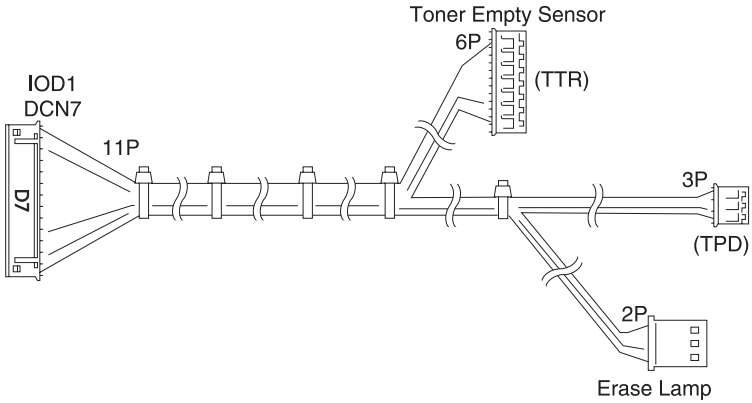

### Cable 9 Connector Assignments

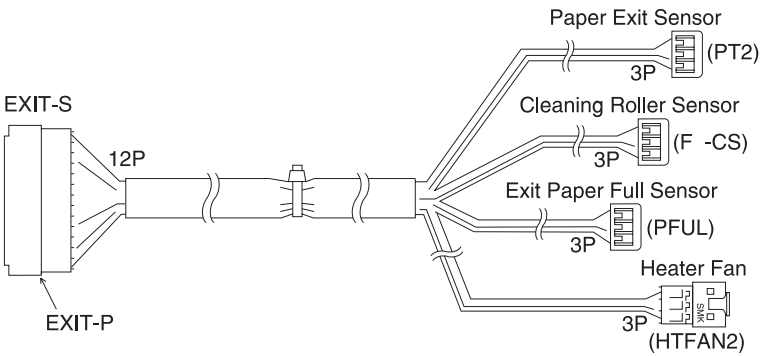

### Cable 10 Connector Assignments

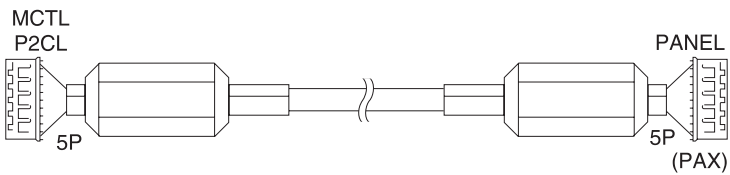

### Cable 11 Connector Assignments

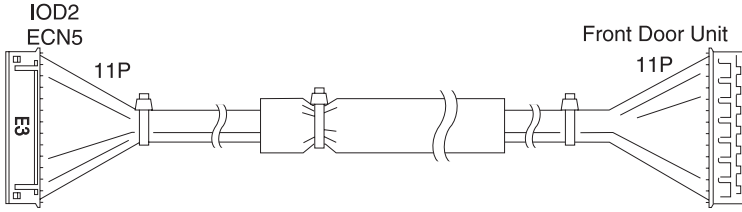

### Cable 12 Connector Assignments

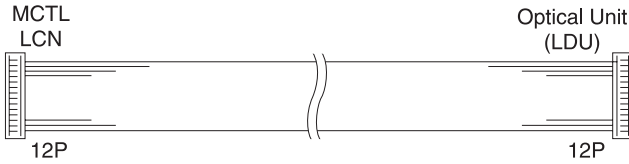

### Cable 13 Connector Assignments

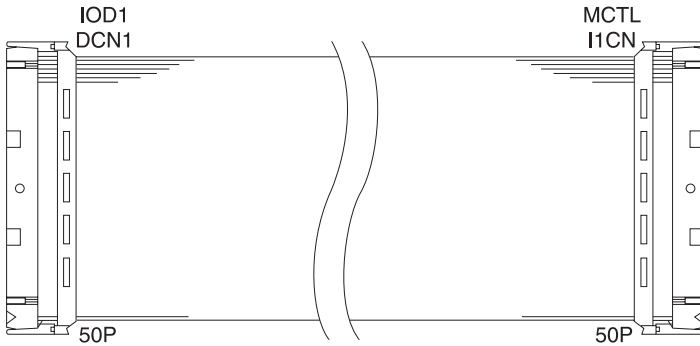

**5024-001**

---

## 6. Preventive Maintenance

This chapter describes procedures for printer preventive maintenance. The following recommendations may prevent problems while maintaining optimum performance.

---

### Safety Inspection Guide

The purpose of this inspection guide is to aid in identifying unsafe conditions. If an unsafe condition exists, determine how serious the danger before correcting the hazard.

Check the following:

- Damaged, missing or altered parts, especially in the area of the On/Off switch, HVPS or LVPS.
- Damaged, missing, or altered covers, especially the top covers and power supply cover.
- Possible safety exposure from any non-Lexmark attachments.

---

### Service Precautions

- Make sure any ground wires are secured to the frame with lock washers or lock washer equipped screws.
- Use the correct fasteners such as screws, lock washers or E-clips when servicing the printer.

---

### Cleaning Procedures

The cleaning of rollers in the printer or options, should be performed with a clean lint-less cloth and distilled water. The use of Isopropyl alcohol is not recommended.

---

## Lubrication Specifications

There are no lubrication requirements for the printer or options.

**Note:** For supplies maintenance, see the *Operator Manual*.

## Printer Supplies and Maintenance Schedules

Supply Name	Description	Schedule
Fuser Cleaner Roller	Roller clean fuser roll	12,000 pages
Fuser Maintenance Kit	Fuses toner to media (consists of fuser and air filter).	40,000 pages
Oil Bottle Kit	Oil for fuser (consists of oil bottle and fuser cleaning roll).	12,000 pages
Paper Exit Rollers	Replace at the time of trouble due to wear.	
Paper Feed Rolls	Replace at the time of trouble due to wear.	
Paper Feed Separation Pads	Replace at the time of trouble due to wear.	
Paper Transport Rollers	Replace at the time of trouble due to wear.	
Photo Developer (OPC Belt Cartridge)	Transfers toner to the image drum.	40,000 images
Toner Cartridge	Black cartridge	12,000 pages each
Toner Cartridges	Magenta, cyan, or yellow cartridges	7,200 pages each
Transfer Roller Maintenance Kit	Transfers image to media (consists of transfer roller and discharger).	120,000 pages
Transparencies	A4 and letter size.	
Waste Toner Bottle	Collects excess toner from the photoconductor.	12,000 images

---

## Cleaning for Maintenance

The following areas need maintenance cleaning when parts are replaced.

- Registration roller
- Transfer roller
- Paper discharger
- Belt cartridge
- Dust proof glass of optical unit
- Printer interior

**Note:** The lower feed and duplex units do not need preventive maintenance.

### **CAUTION:**

- Before starting any maintenance work, make sure to unplug the power supply cord from the outlet.
- There is a risk of electric shock in working while the printer is energized.



---

## 7. Parts Catalog

---

### How to Use this Parts Catalog

---

- **SIMILAR ASSEMBLIES:** If two assemblies contain a majority of identical parts, they are shown on the same list. Common parts are shown by one index number. Parts peculiar to one or the other of the assemblies are listed separately and identified by description.
- **AR:** (As Required) in the Units column indicates that the quantity is not the same for all machines.
- **NP:** (Non-Procurable) in the Units column indicates that the part is non-procurable and that the individual parts or the next higher assembly should be ordered.
- **NR:** (Not Recommended) in the Units column indicates that the part is procurable but not recommended for field replacement, and that the next higher assembly should be ordered.
- **R:** (Restricted) in the Units column indicates that the part has a restricted availability.
- **NS:** (Not Shown) in the Ref column indicates that the part is procurable but is not pictured in the illustration.
- **PP:** (Parts Packet) in the Description column indicates that the part is contained in a parts packet.
- A part reference within a circle indicates an assembly or a bill-of-material. An assembly is complete. A bill-of-material contains unassembled parts.
- **NA:** Not available/not referenced.

# Assembly 1:

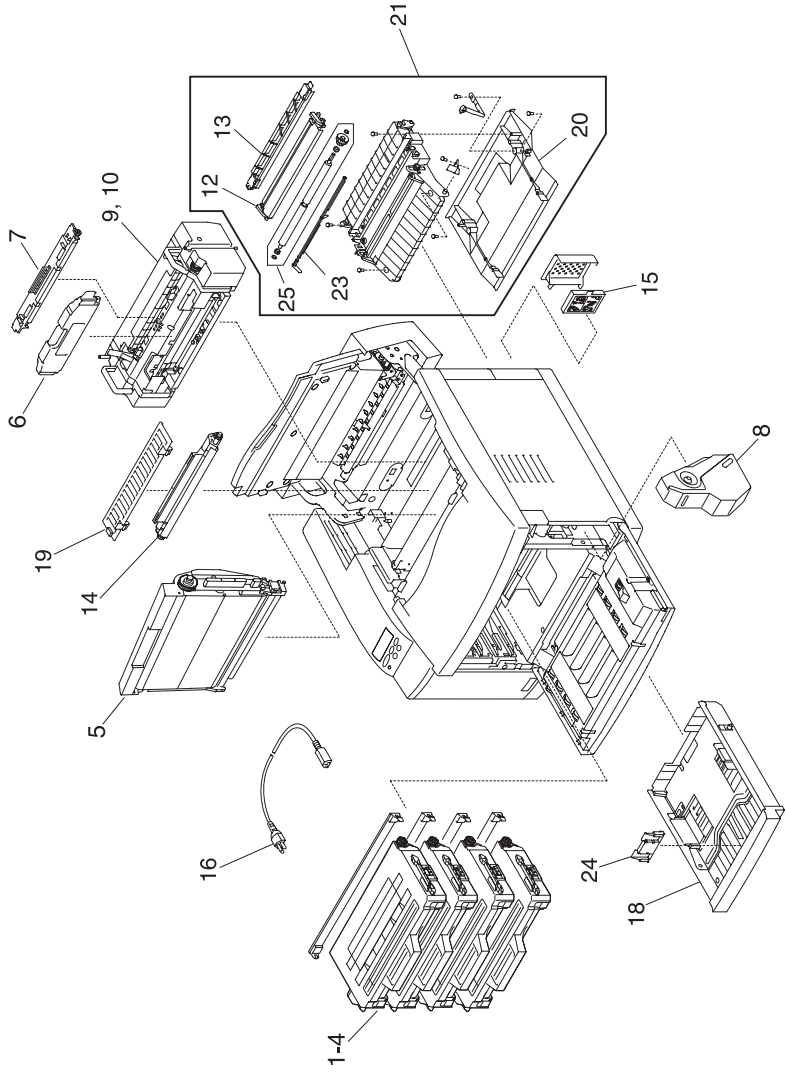

**Assembly 1:**

Ref	Part Number	Units	Description
1 - 1		1	Toner Cartridge -Y (Supply, customer order only)
2		1	Toner Cartridge -M (Supply, customer order only)
3		1	Toner Cartridge -C (Supply, customer order only)
4		1	Toner Cartridge -K (Supply, customer order only)
5		1	OPC Belt Cartridge (Supply, customer order only)
6		1	Fuser Oil Bottle (Supply, customer order only)
7		1	Fuser Cleaner (Supply, customer order only)
8		1	Waste Toner-P (Supply, customer order only)
9		1	Fusing Unit (110V) (Supply, customer order only)
10		1	Fusing Unit (220V) (Supply, customer order only)
12	12G7004	1	Transfer Roller
13	12G7005	1	Paper Discharger
14	12G7006	1	Drum Cleaner
15	12G7007	1	Ozone Filter
16	12G7008	1	Power Cord (U.S.)
16	1339517	1	Power Cord, LV U.S., APG, Bolivia, Canada, Columbia, Costa Rica, Ecuador, EL Salvador, Guatemala, Honduras, Mexico, Nicaragua, Panama, Peru, Venezuela
16	1339518	1	Power Cord, HV, Argentina

# Assembly 1 (cont.):

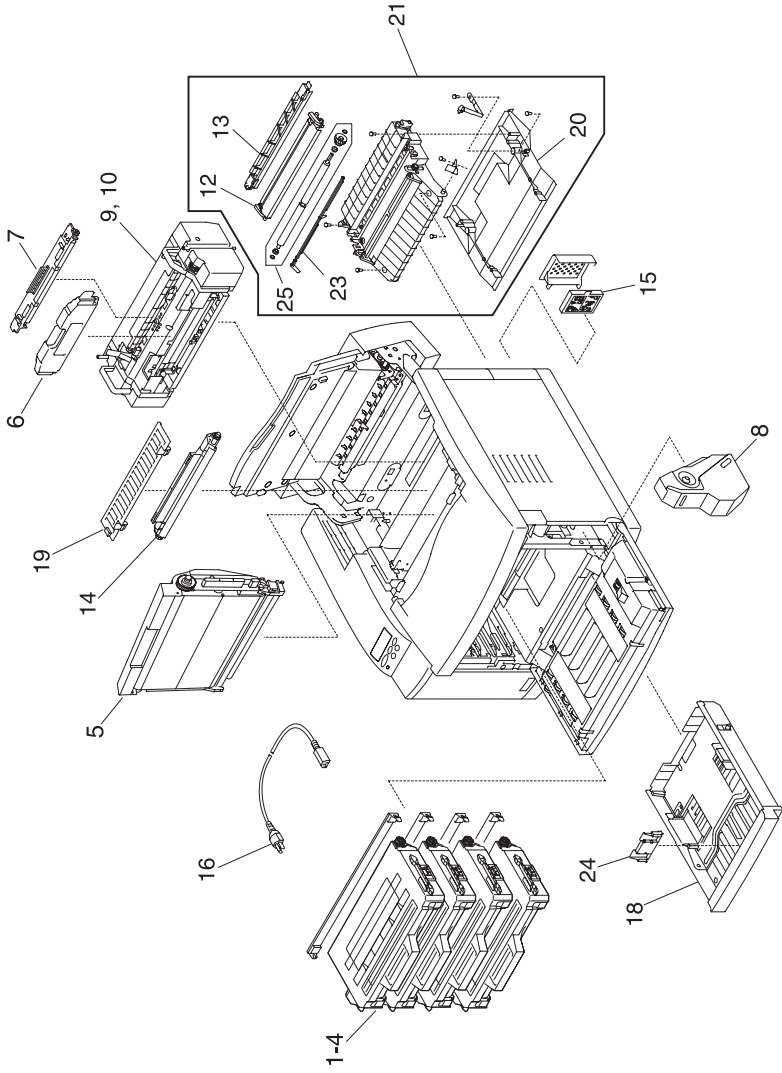

**Assembly 1 (cont.):**

Ref	Part Number	Units	Description
1 - 16	1339520	1	Power Cord, HV, Brazil
16	1339524	1	Power Cord, HV, Chili
16	1339528	1	Power Cord, HV, UK, Ireland
16	1339529	1	Power Cord, HV, Austria, Belgium, EURO English, Finland, France, Germany, Greece, Netherlands, Norway, Poland, Portugal, Russia, Slovakia/Czech/Hungary Spain, Sweden, Turkey
16	1339530	1	Power Cord, HV, Israel
16	1339531	1	Power Cord, HV, Switzerland French, Switzerland German, Switzerland Italian
16	1339532	1	Power Cord, HV, South Africa
16	1339533	1	Power Cord, HV, Italy
16	1339534	1	Power Cord, HV, Denmark
18	12G7010	1	Paper Cassette
18	12G7232	1	Paper Cassette (250 sheet legal)
19	12G7011	1	Cleaner Cover
20	12G7012	1	Transfer Unit Cover
21	12G7013	1	Transfer Unit (includes 12, 13, 20, 23, 25)
23	12G7014	1	PT1 Sensor Lever
24	12G7159	1	Paper Cassette Paper Stop
25	12G7160	1	Registration Roller Assembly
	12G7341	1	Parts Packet, Screws
	12G7340	1	Parts Packet, Cable Clamps, Retainers, Miscellaneous

**Note:** Reference the foldout wiring diagram, in the back of this manual, for cable replacement detailed information. Then go to Assembly 6 for parts ordering information.

# Assembly 2:

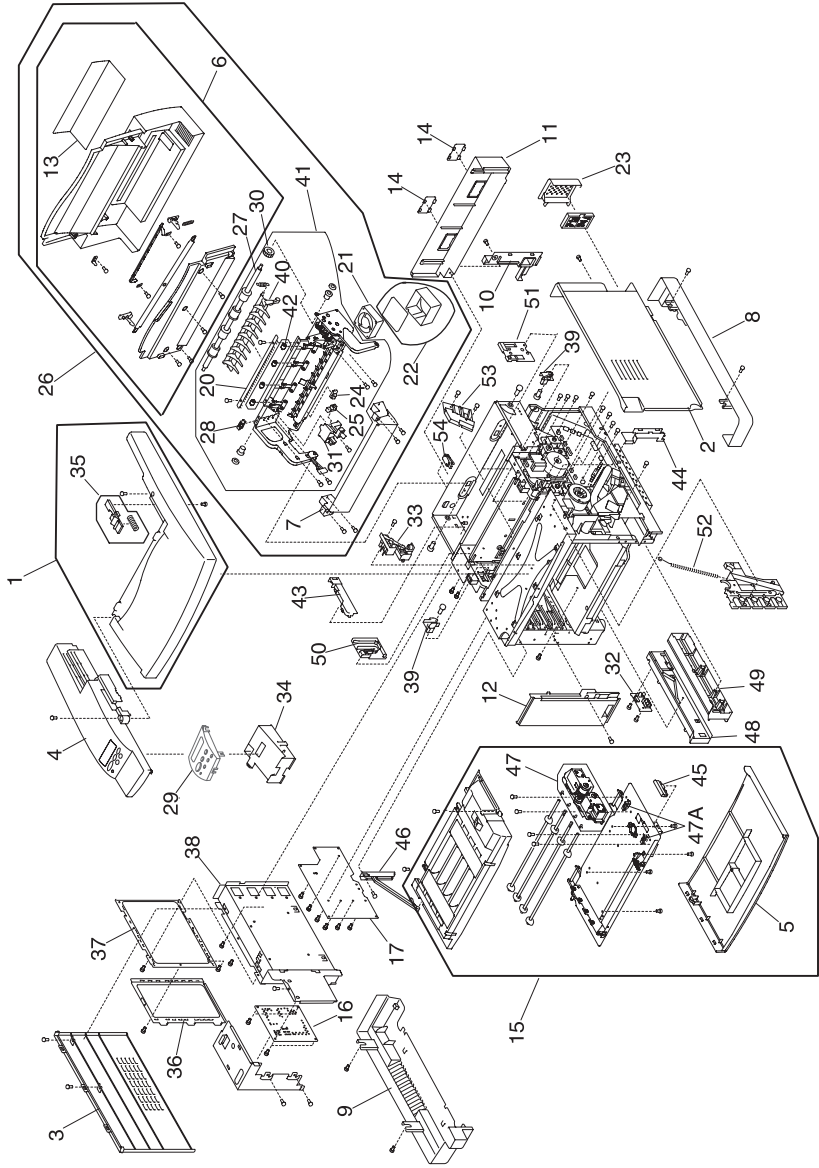

**Assembly 2:**

Ref	Part Number	Units	Description
2 - 1	12G7015	1	Top Cover Assembly (includes 35)
2	12G7016	1	Side Cover (R)
3	12G7017	1	Side Cover (L)
4	12G7018	1	Upper Side Cover (L)
5	12G7019	1	Front Cover
6	12G7020	1	Paper Exit Unit Cover (includes 13)
7	12G7021	1	Paper Exit Front Cover
8	12G7022	1	Base Cover (R)
9	12G7023	1	Base Cover (L)
10	12G7024	1	Rear Cover
11	12G7025	1	Rear Cover (U)
12	12G7026	1	Side F Cover (L)
13	12G7027	1	Paper Exit Upper Cover
14	12G7028	2	Rear Cover (U) Cap
15	12G7029	1	Front Cover Unit (includes 5, 45, 47)
16	12G7030	1	Main Engine (MCTL P.W.B.) Board
17	12G7031	1	High Voltage Unit
20	12G7032	1	Discharge Brush
21	12G7033	1	Cooling Fan (HFAN)
22	12G7034	1	Paper Exit Filter (with Case)
23	12G7035	1	Ozone Filter Cover
24	12G7036	1	Paper Sensor (PT2)
25	12G7037	1	Paper Sensor (FCL)
26	12G7038	1	Paper Exit Unit (includes 6, 7, 13, 20, 21, 22, 24, 25, 27, 28, 30, 31, 40, 42)

## Assembly 2 (cont.):

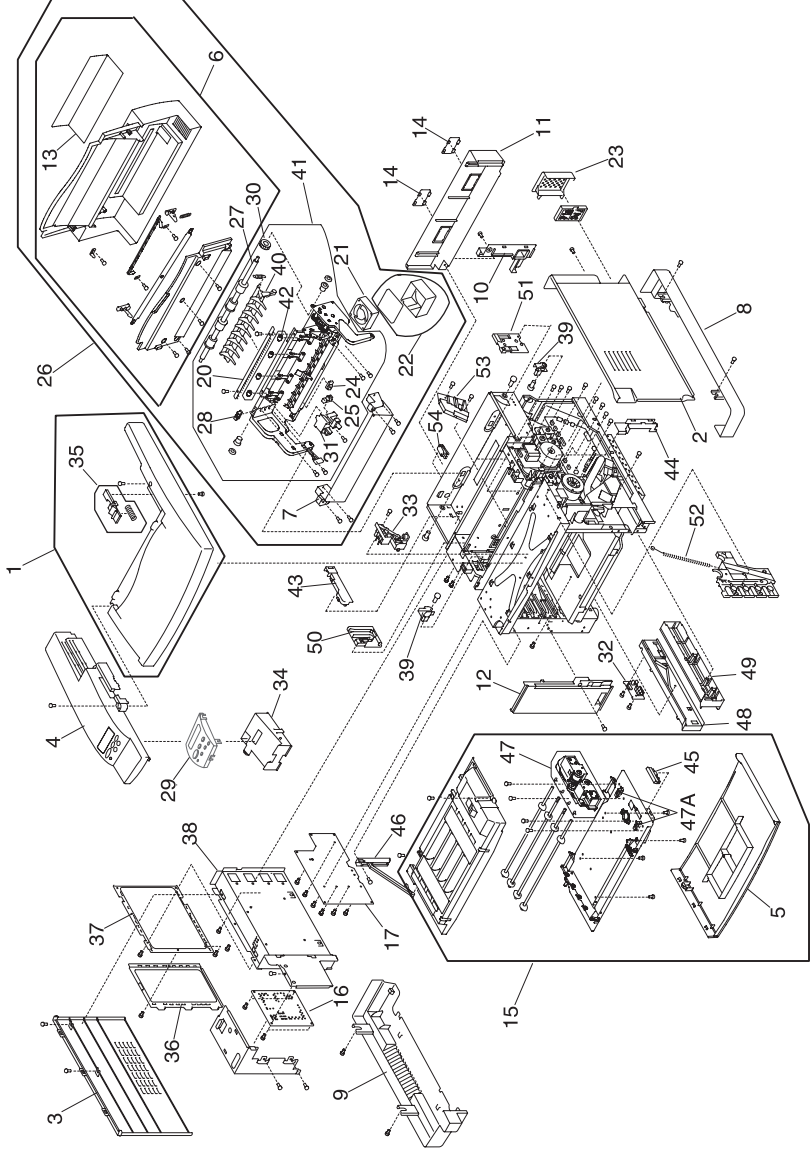



**Assembly 2 (cont.):**

Ref	Part Number	Units	Description
2 - 27	12G7039	1	Paper Exit Roller
28	12G7037	1	Paper sensor (PFUL)
29	12G7360	1	Operator Panel Assembly
30	12G7041	1	Paper Exit Gear Z19
31	12G7042	1	FCS Cover Assembly
32	12G7043	1	Paper Size Sensor
33	12G7044	1	BC Terminal 2
34	12G7161	1	Control Panel Base
35	12G7162	1	Paper Exit Button
36	12G7163	1	Shield Cover B
37	12G7164	1	Shield Cover A
38	12G7165	1	Shield Case Assembly
39	12G7166	1	BC Lock Lever (set)
40	12G7167	1	Paper Exit Switch Guide
41	12G7168	1	Paper Exit Frame Assembly (includes 7,10,24,25,27,28,30,31,40,42)
42	12G7169	1	Paper Exit Idle Roller Set
43	12G7170	1	Paper Exit Harness Cover
44	12G7171	1	IOD Harness Guide
45	12G7172	1	Front Cover Latch
46	12G7173	1	Front Cover/Door Arm Assembly
47	12G7174	1	DE Solenoid Assembly (also order 47A)
47A	12G7036	1	Cam Sensor, DE Solenoid GPH1, GPH2
48	12G7175	1	Front Paper Cassette Guide (L)
49	12G7176	1	Front Paper Cassette Guide (R)

# Assembly 2 (cont.):

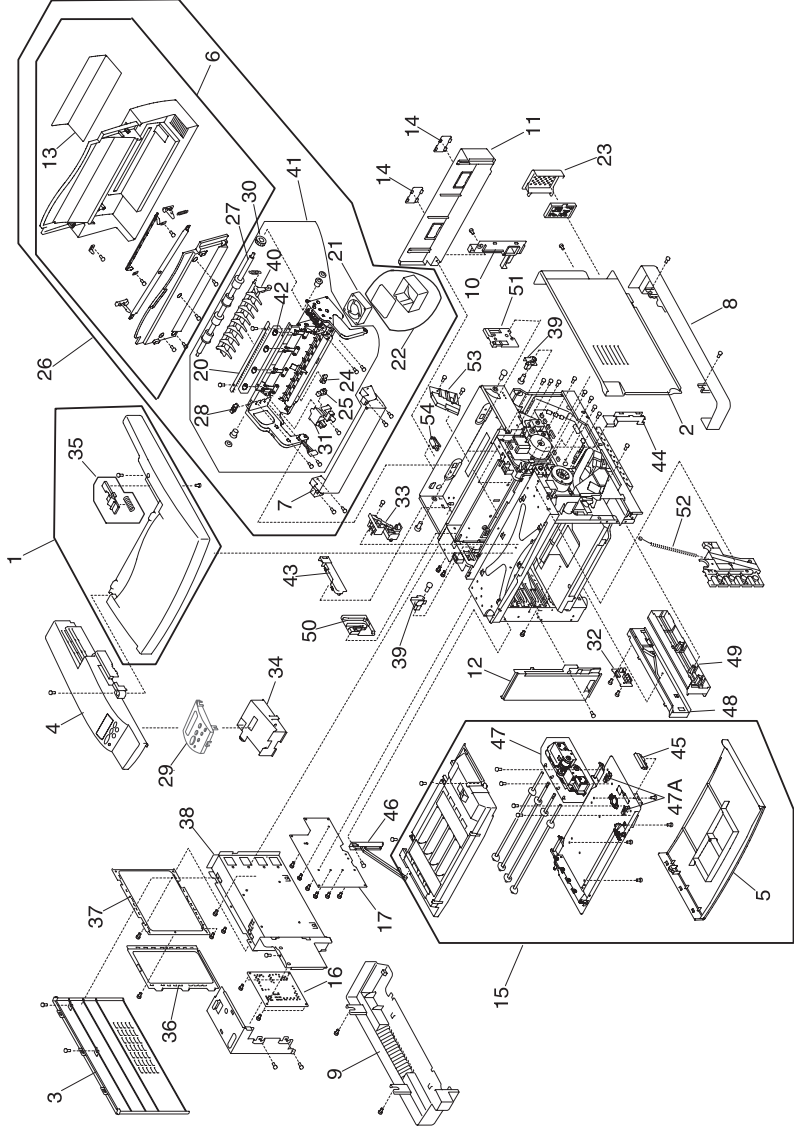

**Assembly 2 (cont.):**

Ref	Part Number	Units	Description
2 - 50	12G7177	1	DC Guide L
51	12G7178	1	DC Guide (R)
52	12G7179	1	Waste Toner U Spring
53	12G7180	1	TR Terminal Base Assembly
54	12G7070	1	Interlock Switch
	12G7341	1	Parts Packet, Screws
	12G7340	1	Parts Packet, Cable Clamps, Retainers, Miscellaneous

**Note:** Reference the foldout wiring diagram, in the back of this manual, for cable replacement detailed information. Then go to Assembly 6 for parts ordering information.

# Assembly 3:

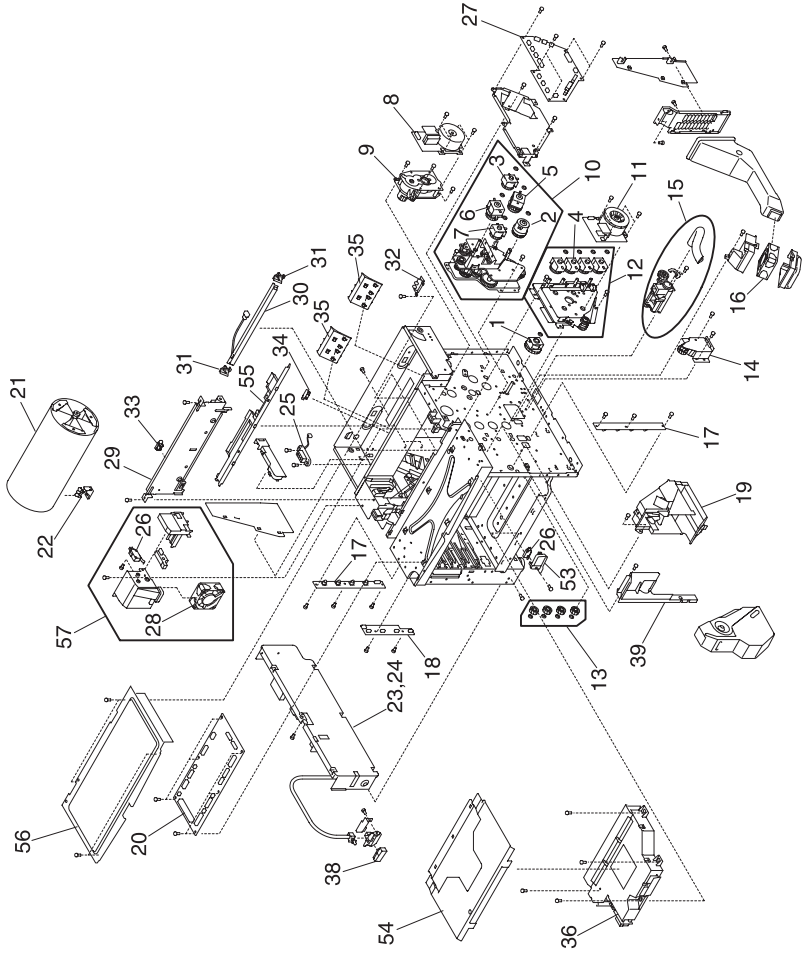

**Assembly 3:**

Ref	Part Number	Units	Description
3 - 1	12G7045	1	Paper Feeding Clutch (PCLU)
2	12G7046	1	Registration Clutch (RECL)
3	12G7047	1	Fuser Clutch (FUCL)
4	12G7048	4	Developer Clutch
5	12G7049	1	Transfer Cam Clutch (TRCM)
6	12G7049	1	Cleaner Cam Clutch (FBCM)
7	12G7051	1	Cleaner Clutch (FBCL)
8	12G7052	1	Main Motor (MM)
9	12G7053	1	BD Gear Assembly
10	12G7054	1	Main Gear Unit (includes 2, 3, 5, 6, 7)
11	12G7055	1	Developer Motor (DM)
12	12G7056	1	Developer Drive Unit (includes 4)
13	12G7057	1	Developer Drive Gear (Set)
14	12G7058	1	FP2 Gear Assembly (Front Developer Solenoid Drive)
15	12G7059	1	Waste Toner Feeder (Lower)
16	12G7060	1	Cooling Fan (OZFAN)
17	12G7061	1	Toner Sensor (TPD, TTR)
18	12G7062	1	Toner Key Sensor (TNK)
19	12G7063	1	Waste Toner Holder Assembly
20	12G7064	1	IOD1 P.W.B.
21	12G7065	1	Transfer Drum
22	12G7037	5	Paper Sensor (Drum Encoder) (HPSEN)
23	12G7067	1	Power Supply Unit (U.S.) 110 V(LVPS)
24	12G7068	1	Power Supply Unit (WT) 220 V (LVPS)

# Assembly 3 (cont.):

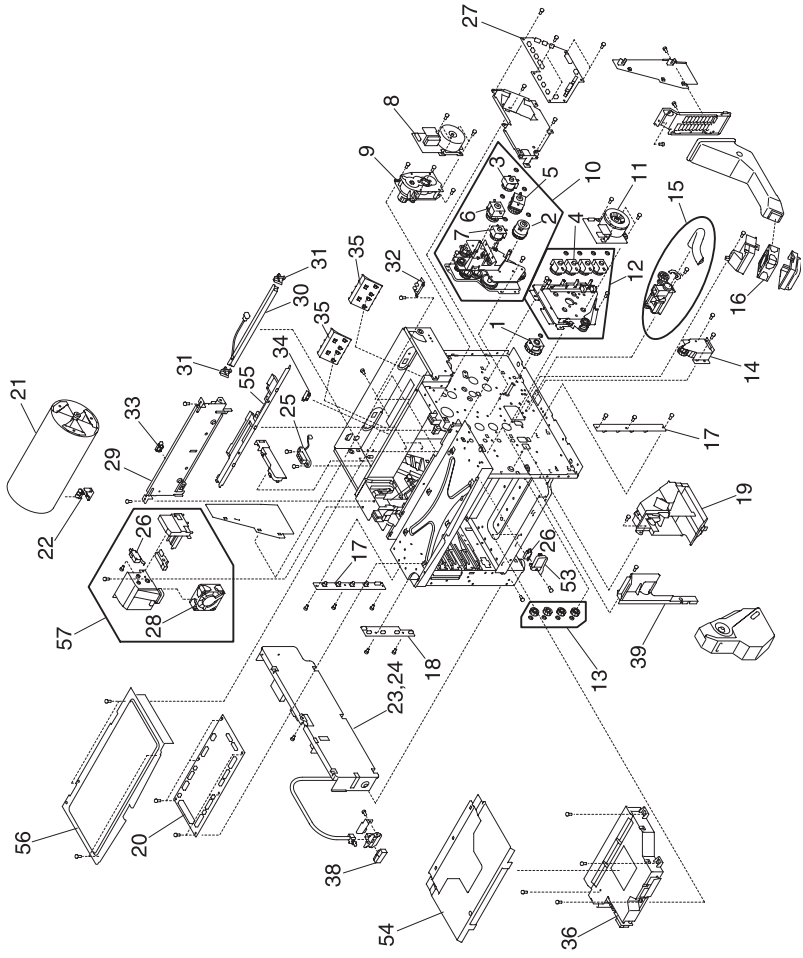

**Assembly 3 (cont.):**

Ref	Part Number	Units	Description
3 - 25	12G7069	1	Fuser Connector
26	12G7070	1	Interlock Switch, Front Door
27	12G7073	1	IOD2 P.W.B.
28	12G7074	1	Cooling Fan (CTFAN)
29	12G7075	1	Waste Toner Feeder Unit (Upper)
30	12G7076	1	Erase Lamp
31	12G7077	2	Erase Holder (2 pieces)
32	12G7078	1	Oil Sensor
33	12G7079	1	Belt Sensor (PBS)
34	12G7079	1	Drum Jam Sensor (DPJ)
35	12G7081	2	Paper Guide D (2 pieces)
36	12G7082	1	Optical Unit (Printhead)
38	12G7083	1	SW Button
39	12G7084	1	Cover (FR)
53	12G7181	1	SW Base Front
54	12G7182	1	Inner Cover C
55	12G7183	1	Oil Sensor Cover
56	12G7184	1	Shield Upper
57	12G7185	1	PS Fan Assembly (CTFAN) (includes 26, 28)
	12G7341	1	Parts Packet, Screws
	12G7340	1	Parts Packet, Cable Clamps, Retainers, Miscellaneous

**Note:** Reference the foldout wiring diagram, in the back of this manual, for cable replacement detailed information. Then go to Assembly 6 for parts ordering information.

## Assembly 4:

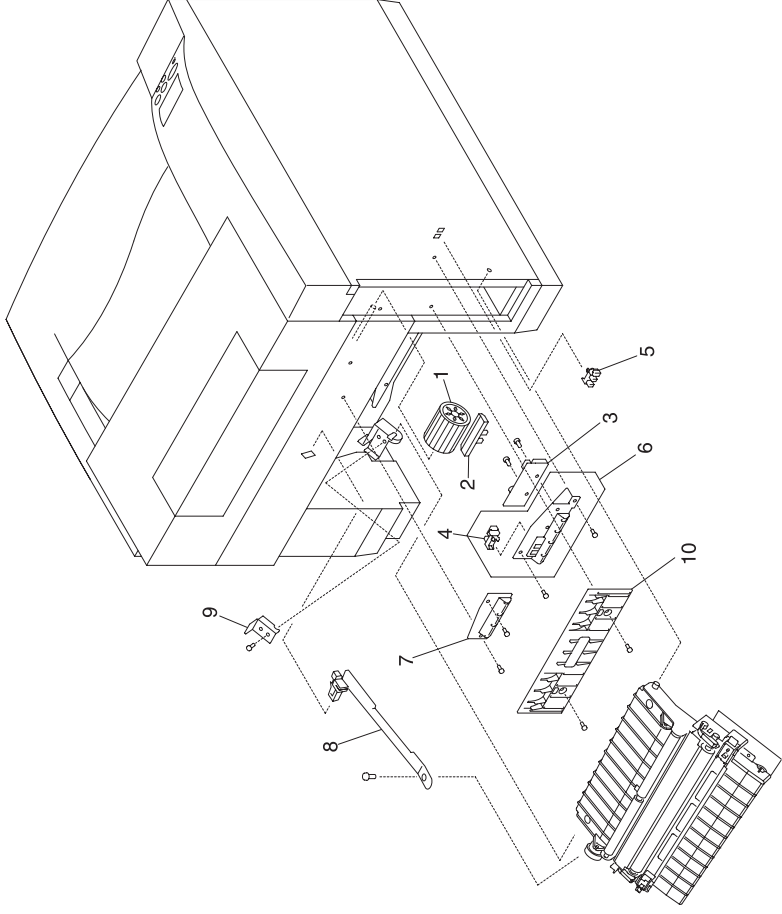



**Assembly 4:**

Ref	Part Number	Units	Description
4 - 1	12G7098	1	Paper Feed Roller
2	12G7099	1	Separator Pad
3	12G7100	1	OHP Sensor
4	12G7037	1	Paper Sensor (PEU)
5	12G7037	1	Paper Sensor (PT1)
6	12G7103	1	Paper Guide (UL) Assembly
7	12G7104	1	Paper Guide (UR)
8	12G7186	1	Transfer Unit Rear Band
9	12G7187	1	Transfer Unit Hinge Support Bracket
10	12G7188	1	Paper Guide L
	12G7341	1	Parts Packet, Screws
	12G7340	1	Parts Packet, Cable Clamps, Retainers, Miscellaneous

**Note:** Reference the foldout wiring diagram, in the back of this manual, for cable replacement detailed information. Then go to Assembly 6 for parts ordering information.

# Assembly 5: Controller RIP Card

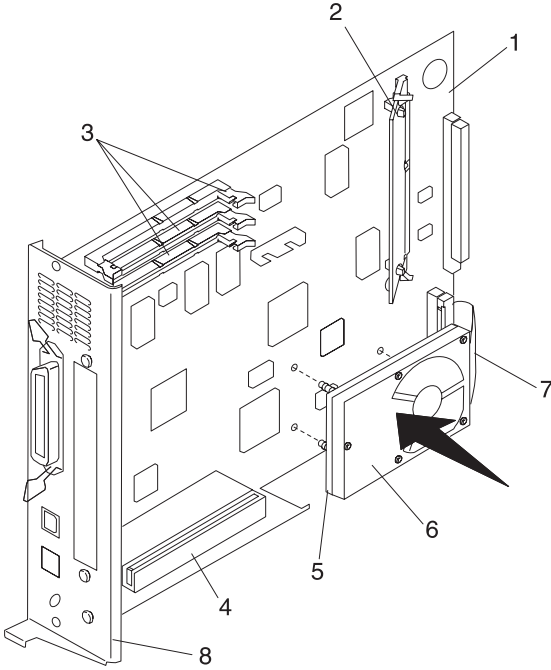

## Assembly 5: Controller RIP Card

Ref	Part Number	Units	Description
5 - 1	12G7226	1	Controller RIP Card
1	12G7227	1	Controller RIP Card Network
2	12G7228	1	SIMM Code
3	99A1752	1	4MB SDRAM DIMM
3	99A1755	1	32MB SDRAM DIMM
4	12G7229	1	Riser Card Assembly
5	12G7231	1	Hard Disk Mounting Bracket
6	99A0459	1	Hard Disk
7	11G0962	1	Hard Disk Cable
8	12G7230	1	Bracket, Controller RIP Card

**Note:** The standard and network models have listed memory. See Assembly 7 for part number information.

# Assembly 6: Printer Cable Harness Sets

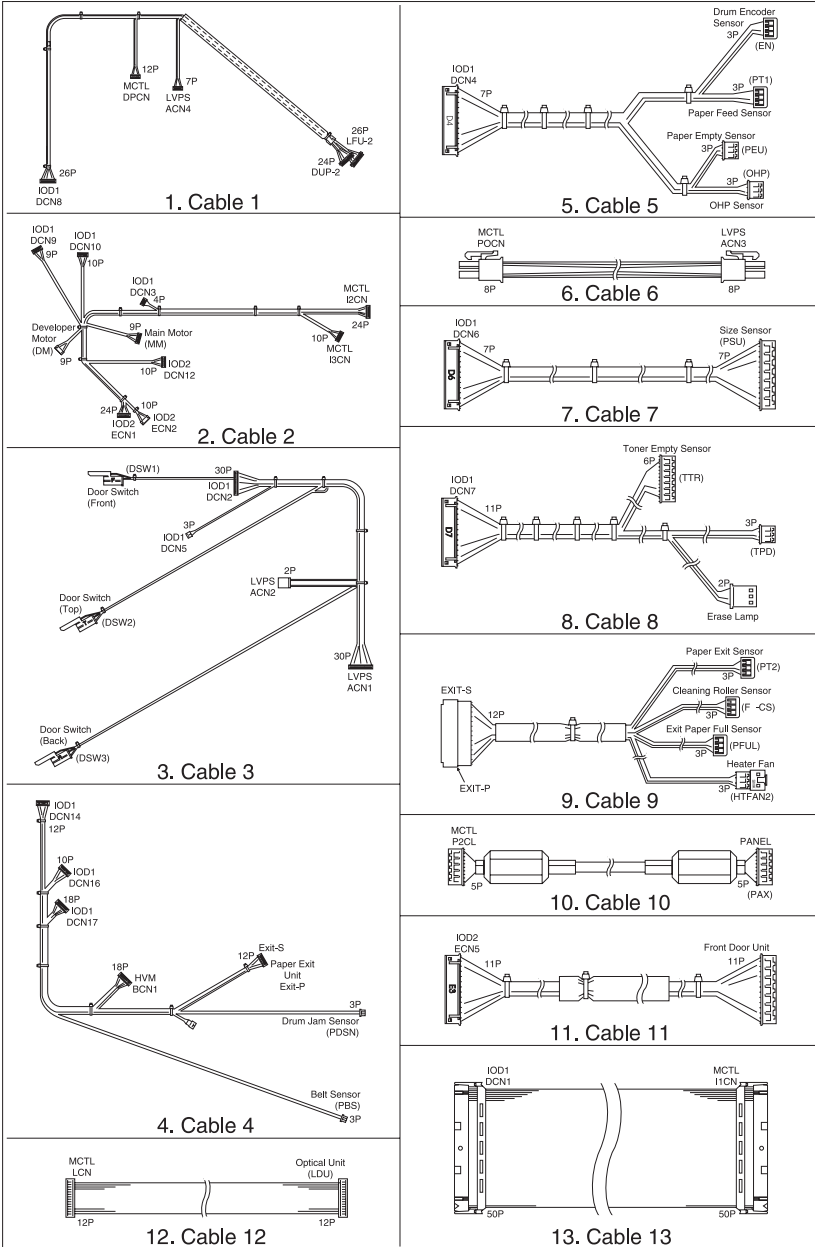

## Assembly 6: Printer Cable Harness Sets

Ref	Part Number	Units	Description
6 - 1	12G7342	1	Harness WH (A) Wiring Diagram #1
2	12G7343	1	Harness WH (B) Wiring Diagram #2
3	12G7344	1	Harness WH (C) Wiring Diagram #3
4	12G7345	1	Harness WH (D) Wiring Diagram #4
5	12G7346	1	Harness WH (I1/SEN) Wiring Diagram #5
6	12G7347	1	Harness WH (LPC) Wiring Diagram #6
7	12G7348	1	Harness WH (SIZE) Wiring Diagram #7
8	12G7349	1	Harness WH (I1/TO) Wiring Diagram #8
9	12G7350	1	Harness WH (PEX) Wiring Diagram #9
10	12G7351	1	Harness WH (LXPN) Wiring Diagram #10
11	12G7352	1	Harness WH (I2/FD) Wiring Diagram #11
12	12G7353	1	Harness WH (DUAL) Wiring Diagram #12
13	12G7354	1	Harness WH (MC/I1) Wiring Diagram #13

**Note:** Reference the foldout wiring diagram, in the back of this manual, for cable replacement detailed information.

5024-001

## **Assembly 7: Miscellaneous**

(No illustration)

**Assembly 7: Miscellaneous**

Ref	Part Number	Units	Description
NS	12G1704	1	Card Assembly, SIMM IPDS/SCS/TNE
NS	13A0297	1	Cable, Coax
NS	13A0296	1	Cable, Twinax
NS	99A0459	1	Hard Disk, 2.1GB
NS	99A0545	1	Adapter, Serial
NS	12G1696	1	MarkNet N2000t 4/16 Token Ring
NS	12G1697	1	MarkNet N2002e 10Base2/10BaseT
NS	99A1830	1	MarkNet N2001e 10/100 Ethernet
NS	99A1752	1	4MB SDRAM DIMM
NS	99A1753	1	8MB SDRAM DIMM
NS	99A1754	1	16MB SDRAM DIMM
NS	99A1755	1	32MB SDRAM DIMM
NS	99A1756	1	64MB SDRAM DIMM
NS	99A1773	1	128MB SDRAM DIMM
NS	99A1757	1	2MB Flash DIMM
NS	99A1758	1	4MB Flash DIMM
NS	99A1759	1	8MB Flash DIMM
NS	99A1774	1	16MB Flash DIMM
NS	99A0560	1	Tri-Port Adapter (Serial/LocalTalk and Infrared)
NS	99A0923	1	Board, USB/Parallel Port
NS	99A0467	1	Board, Parallel Port Adapter
NS			Relocation Packaging
NS	7366394	1	- Base Printer
NS	7366417	1	- Lower Feed Unit
NS	7366413	1	- Duplex Unit
NS	7366409	1	- Base Printer / Duplex bundle

# Assembly 8: Lower Feed Unit

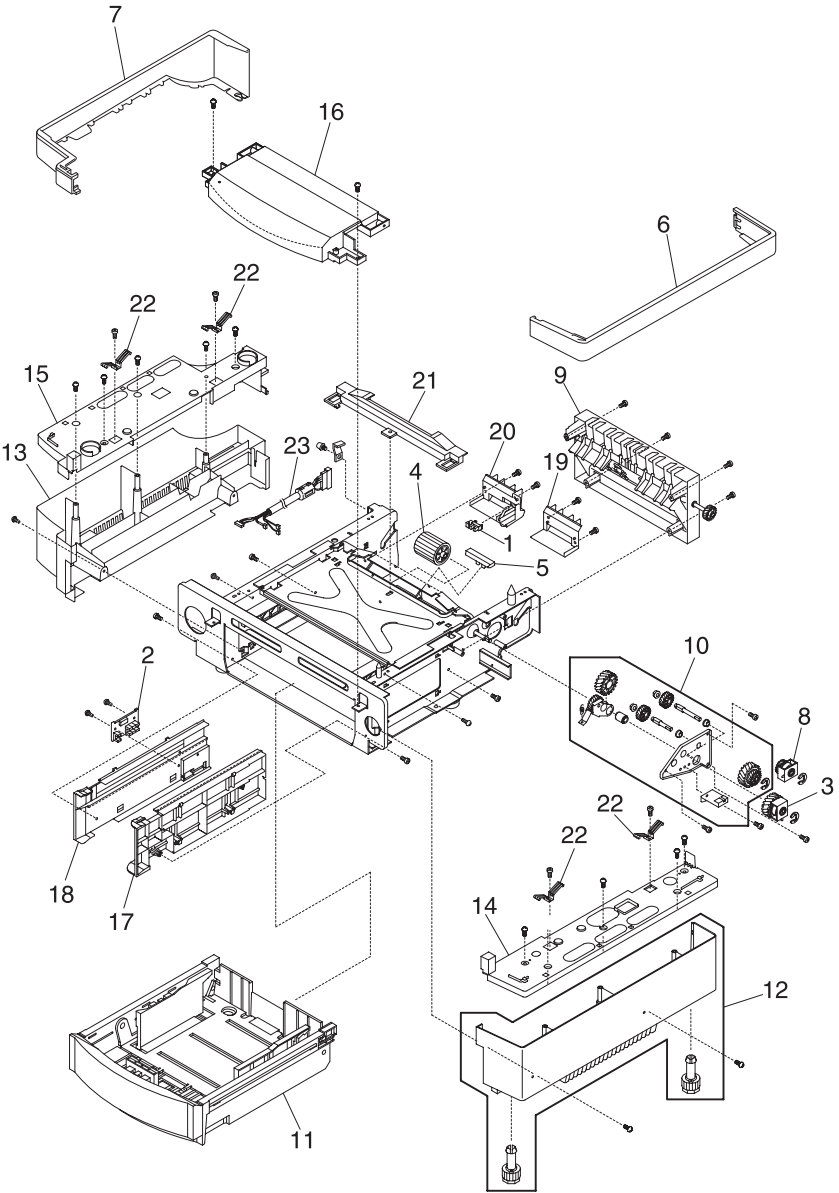



**Assembly 8: Lower Feed Unit**

Ref	Part Number	Units	Description
8 - 1	12G7037	1	Paper Sensor (PEL)
2	12G7043	1	Paper Size Sensor (PSL)
3	12G7045	1	Paper Feed Clutch (PKCL)
4	12G7098	1	Paper Feed Roller
5	12G7099	1	Separator Pad (2)
6	12G7121	1	LF Side Cover R
7	12G7122	1	LF Side Cover L
8	12G7123	1	LF Clutch Drive, Transport Roller (DPKCL)
9	12G7124	1	LF Rear Cover Assembly (includes Transport Roll)
10	12G7144	1	Drive Gear Assembly
11	12G7224	1	LF Paper Feed Cassette
12	12G7145	1	LF Base Cover (R) Assembly
13	12G7146	1	LF Base Cover (L)
14	12G7147	1	LF Top Cover (R)
15	12G7148	1	LF Top Cover (L)
16	12G7149	1	LF Front Top Cover
17	12G7150	1	LF Cassette Guide (R)
18	12G7151	1	LF Cassette Guide (L)
-19	12G7152	1	LF Paper Guide (UR)
20	12G7153	1	LF Paper Guide (UL)
21	12G7154	1	LF Rear Top Cover
22	12G7155	1	GND Contacts
23	12G7156	1	Cable Harness
	12G7135	1	LFU / Duplex Parts Packet, Screws

# Assembly 8 (cont.): Lower Feed Unit (cont.)

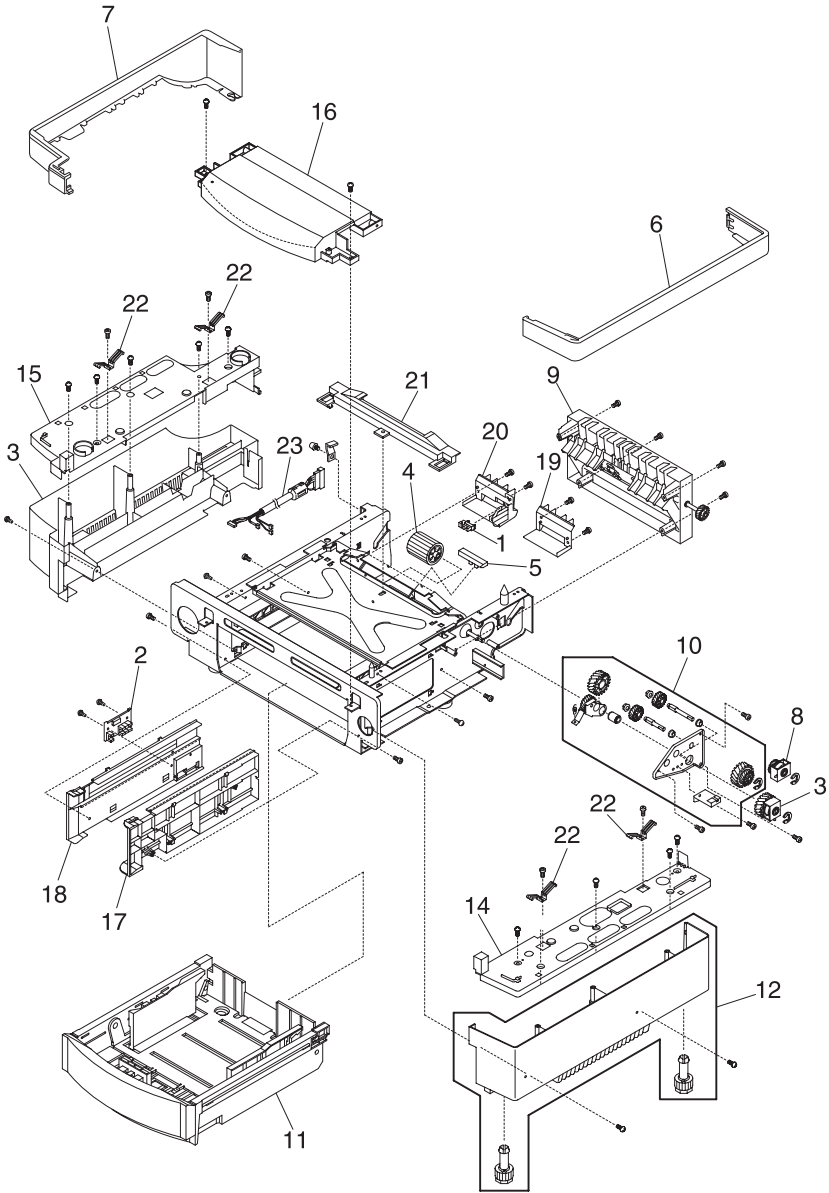

**Assembly 8 (cont.): Lower Feed Unit (cont.)**

Ref	Part Number	Units	Description
	12G7135	1	LFU / Duplex Parts Packet, Screws
	12G7136	1	LFU / Duplex Parts Packet, Retainers
	12G7137	1	LFU / Duplex Parts Packet, Cable Tie / Guides
	12G7139	1	LFU / Duplex Parts Packet, Springs

**Note:** Reference the foldout wiring diagram, in the back of this manual, for cable replacement detailed information. Then go to the assembly for parts ordering information.

# Assembly 9: Duplex Unit

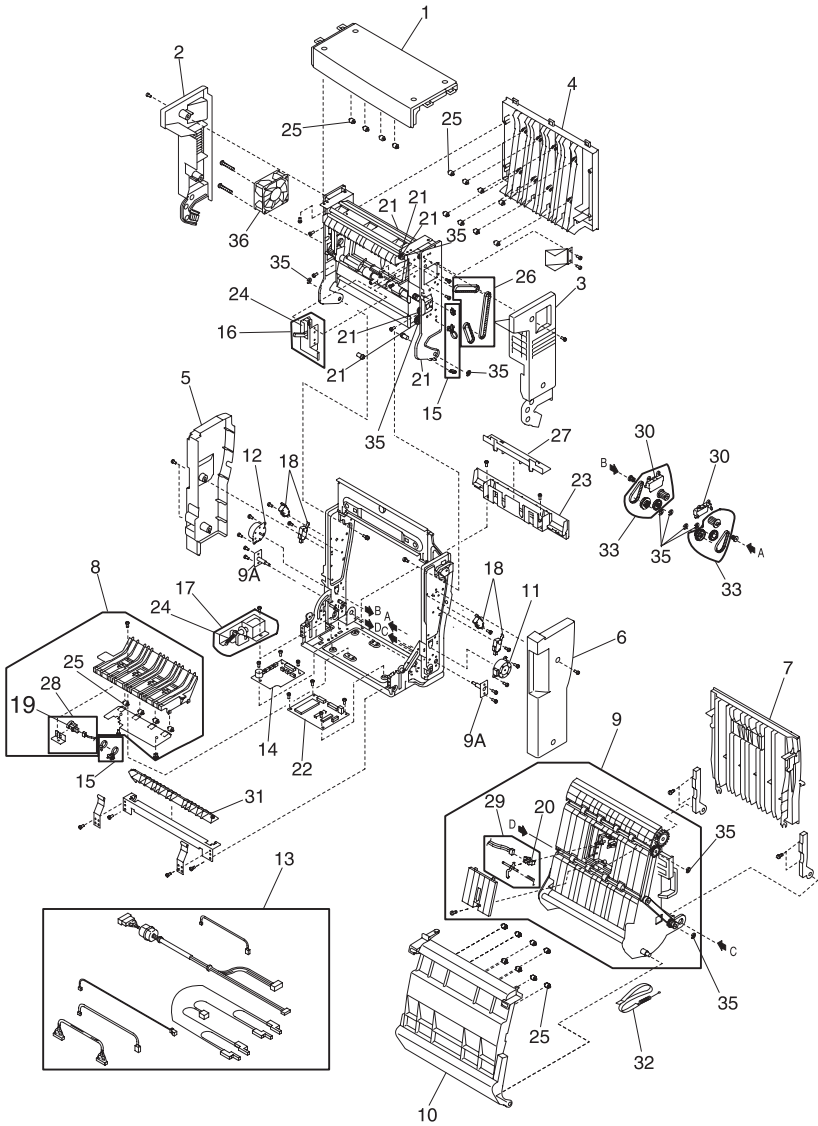

**Assembly 9: Duplex Unit**

Ref	Part Number	Units	Description
9 - 1	12G7105	1	Cover Top (C) Assembly
2	12G7106	1	Cover Top (L)
3	12G7107	1	Cover Top (R)
4	12G7108	1	Cover Top (B) Assembly
5	12G7109	1	Cover Low (L)
6	12G7110	1	Cover Low (R)
7	12G7111	1	Cover Low (B) Assembly
8	12G7112	1	Paper Guide Bottom Assembly (includes 19, 25, 28)
9	12G7113	1	Paper Guide RVS Assembly (includes 20, 29)
10	12G7114	1	Paper Guide Inner
11	12G7115	1	Motor 1(DPM1)
12	12G7116	1	Motor 2 (DPM2)
13	12G7138	1	4 Cable Bill of Material (Door, P.W.B.- P.W.B.,I/F, Solenoid, PT4 P.W.B., Fan)
14	12G7117	1	Relay P.W.B.
16	12G7140	1	Solenoid (U) Assembly
17	12G7141	1	Solenoid (L) Assembly
18	12G7070	4	Interlock Switch (DSW1 - DSW4)
19	12G7143	1	D Sensor (PT4)
20	12G7125	1	D Sensor (PT5)
21	12G7118	1	Paper Guide U Assembly (includes printer reference 26)
22	12G7119	1	DUP P.W.B.

# Assembly 9 (cont.): Duplex Unit (cont.)

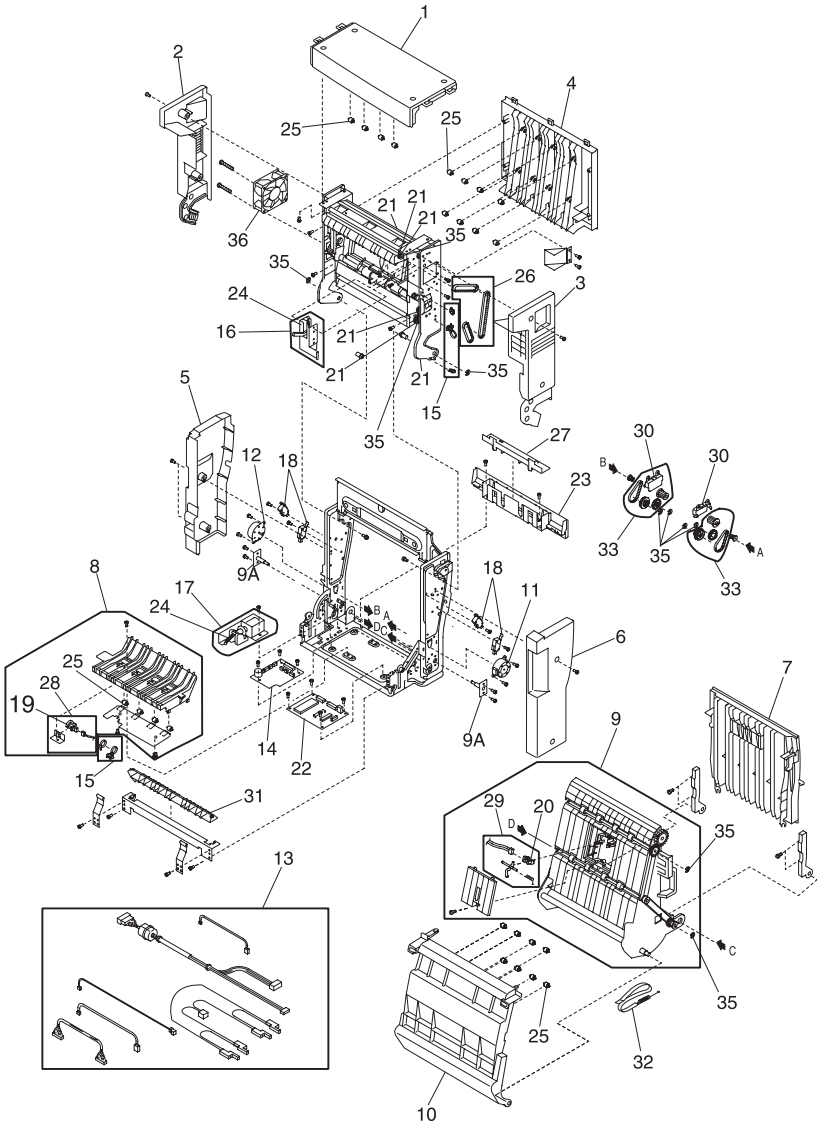

**Assembly 9: Duplex Unit**

Ref	Part Number	Units	Description
9 - 23	12G7120	1	Cover Bottom
24	12G7139	1	Spring (contains 2 springs)
25	12G7126	1	D Roller (contains 20 rollers)
26	12G7127	1	3 Belts
27	12G7128	1	Lid-WH Bottom
28	12G7129	1	D Sensor Bottom Bill of Material
29	12G7130	1	D Sensor Middle Bill of Material
30	12G7131	2	D Gear Cover
31	12G7132	1	Gate Bottom
32	12G7133	1	Band-Spring Set
33	12G7134	2	3 Gears-Belt Set
35	12G7136	1	LFU / Duplex Screw Parts Pack
36	12G7138	1	Fan Motor (DFAN)
	12G7135	1	LFU / Duplex Parts Packet, Screws
	12G7136	1	LFU / Duplex Parts Packet, Retainers
	12G7137	1	LFU / Duplex Parts Packet, Cable Tie / Guides
	12G7139	1	LFU / Duplex Parts Packet, Springs

**Note:** Reference the foldout wiring diagram, in the back of this manual, for cable replacement detailed information. Then go to the assembly for parts ordering information.

**5024-001**



# Index

## A

- Acronyms 1-3
- Adjustments 4-4
- Assemblies
  - Assembly 1 7-3
  - Assembly 2 7-7
  - Assembly 3 7-13
  - Assembly 4 7-17
- Cable Harness Sets 7-21
- Controller RIP Card 7-19
- Duplex Unit 7-28
- Lower Feed Unit 7-24
- Miscellaneous 7-23

## B

- Belt Cleaning Process 1-31
- Belt Discharge (Erase Lamp) Process 1-30

## C

- Charging Process 1-23
- Cleaning Procedures 6-1
- Control System 1-42
  - Control of Print Process 1-43
  - Electrical System and Function 1-42
- Laser Drive Control Circuit 1-45

## D

- Developing Process 1-26
- Diagnostic Aids
  - Button Test 3-9
  - Device Tests 3-14
  - Diagnostic Mode 3-5
  - Diagnostics Menu Structure 3-6
  - Disabling Download Emulations 3-1
  - Disk Test/Clean 3-14
  - Duplex Tests 3-13
  - Error Log 3-19
    - Clearing 3-20, I-1
    - Viewing 3-19
  - Exiting Diagnostic Mode 3-21

- Flash Test 3-15
- Hardware Tests 3-9
- LCD Test 3-9
- Paper Jam Sequence 3-2
- Parallel Strobe Adjustment 3-18
- Parallel Wrap Test 3-10
- Print Registration 3-7
- Print Tests 3-8
- Printer Setup 3-16
- Resetting Counters 3-19
- Restore EP Factory Defaults 3-20
- ROM Memory Test 3-10
- SDRAM Memory Test 3-11
- Serial Number 3-16
- Serial Wrap Test 3-12
- Setting Configuration ID 3-17
- Setting the Page Count 3-16
- Setting Top Margin 3-7
- Viewing Page Count 3-16
- Diagnostic Information 2-1
  - Operator Messages 2-9
  - Paper Jam Messages 2-27
  - Printer Service Checks 2-38
  - Service Error Codes 2-2
  - Symptom Tables 2-32
- Diagnostic Mode 3-5
- Drum Cleaner Process 1-34

## E

- Electrical System and Function 1-42
- Error Codes
  - Operator Messages 2-9
  - Service Error Codes 2-2
- Exposing Process 1-25

## F

- First Transfer (Drum) Process 1-28
- Fusing Process 1-41
- Fusing Unit 1-39

## I

- Interface Control 1-47

## 5024-001

- Interface Connection 1-47
- Interface Type 1-47

## L

- Laser Drive Control Circuit 1-45
  - Laser Notices xiii
  - Locations 5-1
    - Boards 5-6
    - Connector Pin Assignments 5-24
    - Controller RIP Card 5-15
    - Fans and Motors 5-8
    - Fuser Unit Board 5-21
    - High Voltage Unit Board 5-20
    - IOD1 P.W.B. Board 5-17
    - IOD2 P.W.B. Board 5-18
    - Low Voltage Power Supply Board 5-19
    - Main Engine (MCTL P.W.B.) Board 5-16
    - Optional Duplex Unit Board 5-23
    - Optional Lower Feed Unit Board 5-22
  - Options 5-3
  - Printer 5-1
  - Printer Cables 5-46
  - Sensors 5-4
  - Solenoids and Clutches 5-9
  - Wiring Diagram and Cable Harness Reference 5-13
- Lubrication 6-2

## M

- Maintenance
  - Cleaning 6-4
  - Cleaning Procedures 6-1
  - Lubrication 6-2
  - Precautions 6-1
  - Safety 6-1
  - Supplies and Maintenance Schedules 6-3
- Maintenance Approach 1-1
- Messages
  - Operator 2-9
  - Paper Jam 2-27

## O

- Optical System 1-35

## P

- Paper Discharging Process 1-33
- Paper Jam Sequence 3-2
- Paper Transportation System 1-37
  - Fusing Process 1-41
  - Fusing Unit 1-39
- Parts Catalog 7-1
- Print Sequence Diagram 1-44
- Print System
  - Belt Cleaning Process 1-31
  - Belt Discharge (Erase Lamp) Process 1-30
  - Charging Process 1-23
  - Developing Process 1-26
  - Exposing Process 1-25
  - First Transfer (Drum) Process 1-28
- Printer Setup
  - Parallel Strobe Adjustment 3-18
  - Serial Number 3-16
  - Setting Configuration ID 3-17
  - Setting the Page Count 3-16
  - Viewing Page Count 3-16

## R

- Removals 4-1
  - Boards 4-23
  - Clutches and Solenoids 4-52
  - Covers 4-6
  - Duplex 4-104
  - Fans / Motors 4-37
  - Fuser Unit 4-93
  - Lower Feeder Unit 4-94
  - Sensors 4-58
  - Transfer Unit 4-79
- Resetting Counters 3-19

## S

- Safety Information xxiv
- Second Transfer (Paper) Process 1-32
- Serial Number 3-16
- Service Checks

## 5024-001

Paper Feed 2-77  
Print Quality 2-83  
Printer 2-38  
Service Precautions 6-1  
Spacing Table 2-106  
Standard Features  
  Main Printer 1-4  
  Options 1-4  
Symptom Tables  
  Optional Duplex Unit 2-37  
  Optional Lower Feed Unit 2-36  
  Print Quality 2-34  
  Printer 2-32

## T

### Tests

  Button 3-9  
  Device 3-14  
  Disk Test/Clean 3-14  
  Duplex Tests 3-13  
  Flash Test 3-15  
  Hardware 3-9  
  LCD 3-9  
  Parallel Wrap 3-10  
  ROM Memory 3-10  
  SDRAM Memory 3-11  
  Serial Wrap 3-12  
Theory of Operation 1-14  
  Duplex Unit 1-49  
  Lower Feed Unit 1-48  
  Printer 1-14  
Transfer System 1-32  
  Drum Cleaner Process 1-34  
  Paper Discharging Process 1-33  
  Second Transfer (Paper) Process  
    1-32  
Troubleshooting  
  Paper Jams 2-28

## Part Numbers

11G0962 7-19  
12G1696 7-23  
12G1697 7-23  
12G1704 7-23  
12G7004 7-3  
12G7005 7-3

12G7006 7-3  
12G7007 7-3  
12G7008 7-3  
12G7010 7-5  
12G7011 7-5  
12G7012 7-5  
12G7013 7-5  
12G7014 7-5  
12G7015 7-7  
12G7016 7-7  
12G7017 7-7  
12G7018 7-7  
12G7019 7-7, 7-11  
12G7020 7-7  
12G7021 7-7  
12G7022 7-7  
12G7023 7-7  
12G7024 7-7  
12G7025 7-7  
12G7026 7-7  
12G7027 7-7  
12G7028 7-7  
12G7029 7-7  
12G7030 7-7  
12G7031 7-7  
12G7032 7-7  
12G7033 7-7  
12G7034 7-7  
12G7035 7-7  
12G7036 7-7, 7-9  
12G7037 7-7, 7-9, 7-13, 7-17, 7-25  
12G7038 7-7  
12G7039 7-9  
12G7041 7-9  
12G7042 7-9  
12G7043 7-9, 7-25  
12G7044 7-9  
12G7045 7-13, 7-25  
12G7046 7-13  
12G7047 7-13  
12G7048 7-13  
12G7049 7-13  
12G7051 7-13  
12G7052 7-13  
12G7053 7-13  
12G7054 7-13  
12G7055 7-13

## 5024-001

12G7056	7-13	12G7122	7-25
12G7057	7-13	12G7123	7-25
12G7058	7-13	12G7124	7-25
12G7059	7-13	12G7125	7-29
12G7060	7-13	12G7126	7-31
12G7061	7-13	12G7127	7-31
12G7062	7-13	12G7128	7-31
12G7063	7-13	12G7129	7-31
12G7064	7-13	12G7130	7-31
12G7065	7-13	12G7131	7-31
12G7067	7-13	12G7132	7-31
12G7068	7-13	12G7133	7-31
12G7069	7-15	12G7134	7-31
12G7070	7-11, 7-15, 7-29	12G7135	7-25, 7-27, 7-31
12G7073	7-15	12G7136	7-27, 7-31
12G7074	7-15	12G7137	7-27, 7-31
12G7075	7-15	12G7138	7-29, 7-31
12G7076	7-15	12G7139	7-27, 7-31
12G7077	7-15	12G7140	7-29
12G7078	7-15	12G7141	7-29
12G7079	7-15	12G7143	7-29
12G7081	7-15	12G7144	7-25
12G7082	7-15	12G7145	7-25
12G7083	7-15	12G7146	7-25
12G7084	7-15	12G7147	7-25
12G7098	7-17, 7-25	12G7148	7-25
12G7099	7-17, 7-25	12G7149	7-25
12G7100	7-17	12G7150	7-25
12G7103	7-17	12G7151	7-25
12G7104	7-17	12G7152	7-25
12G7105	7-29	12G7153	7-25
12G7106	7-29	12G7154	7-25
12G7107	7-29	12G7155	7-25
12G7108	7-29	12G7156	7-25
12G7109	7-29	12G7159	7-5
12G7110	7-29	12G7160	7-5
12G7111	7-29	12G7161	7-9
12G7112	7-29	12G7162	7-9
12G7113	7-29	12G7163	7-9
12G7114	7-29	12G7164	7-9
12G7115	7-29	12G7165	7-9
12G7116	7-29	12G7166	7-9
12G7117	7-29	12G7167	7-9
12G7118	7-29	12G7168	7-9
12G7119	7-29	12G7169	7-9
12G7120	7-31	12G7170	7-9
12G7121	7-25	12G7171	7-9

## 5024-001

12G7172	7-9	1339529	7-5
12G7173	7-9	1339530	7-5
12G7174	7-9	1339531	7-5
12G7175	7-9	1339532	7-5
12G7176	7-9	1339533	7-5
12G7177	7-11	1339534	7-5
12G7179	7-11	7366394	7-23
12G7180	7-11	7366409	7-23
12G7181	7-15	7366413	7-23
12G7182	7-15	7366417	7-23
12G7183	7-15	99A0459	7-19, 7-23
12G7184	7-15	99A0467	7-23
12G7185	7-15	99A0545	7-23
12G7186	7-17	99A0560	7-23
12G7187	7-17	99A0923	7-23
12G7188	7-17	99A1752	7-19, 7-23
12G7224	7-25	99A1753	7-23
12G7226	7-19	99A1754	7-23
12G7227	7-19	99A1755	7-19, 7-23
12G7228	7-19	99A1756	7-23
12G7229	7-19	99A1757	7-23
12G7230	7-19	99A1758	7-23
12G7231	7-19	99A1759	7-23
12G7232	7-5	99A1773	7-23
12G7340	7-5, 7-11, 7-15, 7-17	99A1774	7-23
12G7341	7-5, 7-11, 7-15, 7-17	99A1830	7-23
12G7342	7-21		
12G7343	7-21		
12G7344	7-21		
12G7345	7-21		
12G7346	7-21		
12G7347	7-21		
12G7348	7-21		
12G7349	7-21		
12G7350	7-21		
12G7351	7-21		
12G7352	7-21		
12G7353	7-21		
12G7354	7-21		
12G7360	7-9		
13A0296	7-23		
13A0297	7-23		
1339517	7-3		
1339518	7-3		
1339520	7-5		
1339524	7-5		
1339528	7-5		

**5024-001**

**Lexmark C720  
Color Laser Printer  
Machine Type 5024-001**

**Wiring Diagram**

